

CONSTRUCTION NOTES

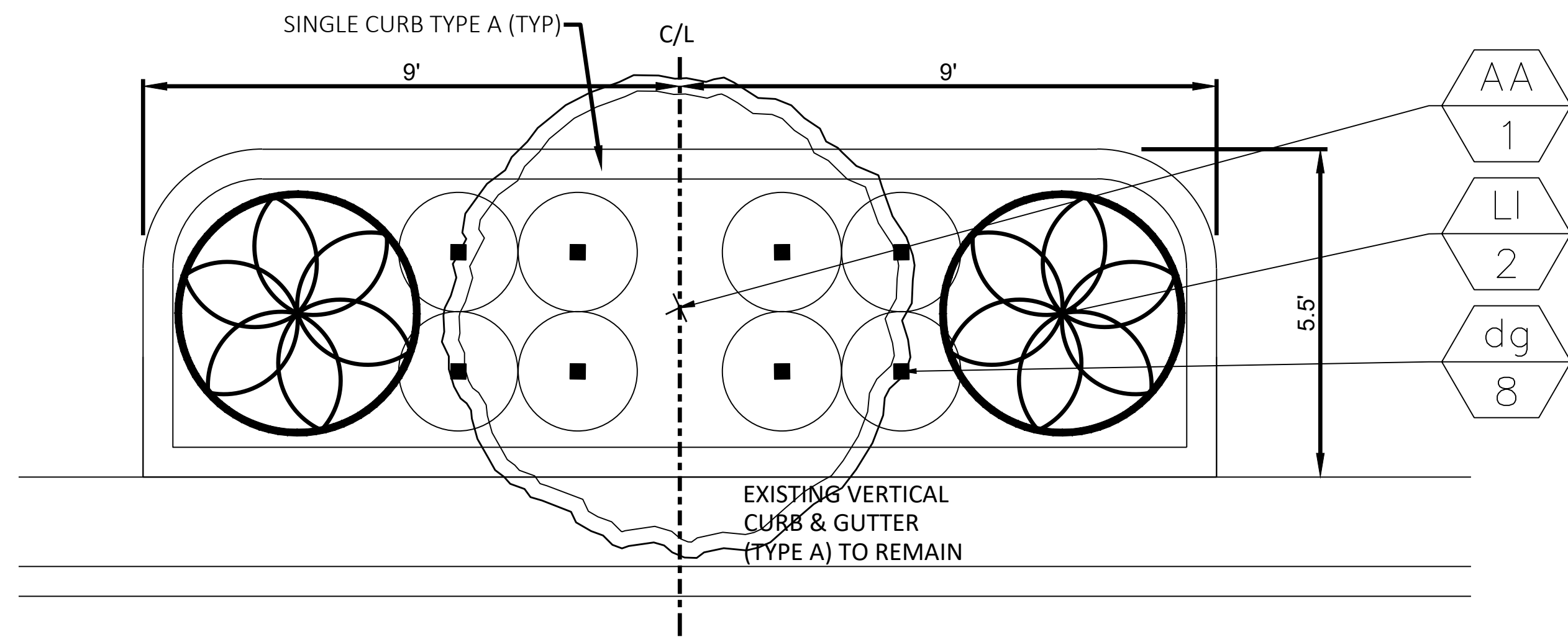

BUMP OUT DETAIL - ALT 1

LANDSCAPE PLANT SCHEDULE

Symbol	Botanical name	Common Name	Size/Root	Quantity
TREES				
AA	<i>Acacia aneura</i>	Mulga	24" Box 1" Cal.	1
PP	<i>Parkinsonia praecox</i>	Palo Brea	24" Box 1" Cal.	1
SHRUBS				
LI	<i>Leucophyllum langmaniae</i>	Langman's Sage	5 Gal.	2
Hp	<i>Hesperaloe parviflora</i>	Red Yucca	5 Gal.	2
GROUND COVER				
dg	<i>Dalea greggii</i>	Trailing Dalea	1 Gal.	4
Im	<i>Lantana montevidensis</i>	Purple Trailing Lantana	1 Gal.	4

NOTES:

1. DECOMPOSED GRANITE TO BE PLACED IN ALL LANDSCAPE AREAS. THE JOB SITE, AT THE COMPLETION OF CONSTRUCTION, SHALL BE CLEANED OF ANY DEBRIS OR SPOIL RESULTING FROM THE CONSTRUCTION. NO JOB WILL BE CONSIDERED COMPLETE UNTIL ALL CURBS, PAVEMENT, AND SIDEWALKS HAVE BEEN INSTALLED ACCORDING TO THE PLANS AND MAG STANDARDS.
2. ALL EQUIPMENT AND MATERIALS NOT SHOWN OR SPECIFIED ON THE PLANS OR IN THE SPECIFICATIONS BUT WHICH ARE REQUIRED TO COMPLETE THIS INSTALLATION SHALL BE SUPPLIED BY THE CONTRACTOR AS PART OF THIS CONTRACT WORK.
3. ALL FRAMES, COVERS, VALVE BOXES, ETC., SHALL BE ADJUSTED TO FINISHED GRADE AFTER PLACING OF PAVEMENT OR PLANTING BEDS BY THE CONTRACTOR PER MAG DETAIL 270 AND 422.
4. ALL LANDSCAPE PLANTS SHALL MEET GRADING, TYPE, ETC AS SPECIFIED IN THE AMERICAN STANDARD FROM NURSERY STOCK BY THE AMERICAN ASSOCIATION OF NURSERYMEN.
5. CONTRACTOR SHALL STAKE ALL PLANT MATERIAL LOCATIONS AND HAVE THEM APPROVED BY OWNER OR LANDSCAPE ARCHITECT PRIOR TO INSTALLATION.
6. CONTRACTOR TO MAKE MINOR ADJUSTMENT TO LANDSCAPE MATERIALS TO AVOID UTILITY OR OTHER CONFLICTS.
7. ANY DAMAGE TO EXISTING PAVEMENT BY THE CONTRACTOR SHALL BE REPAIRED OR REPLACED TO THE EXISTING CONDITION AT NO COST TO THE OWNER.

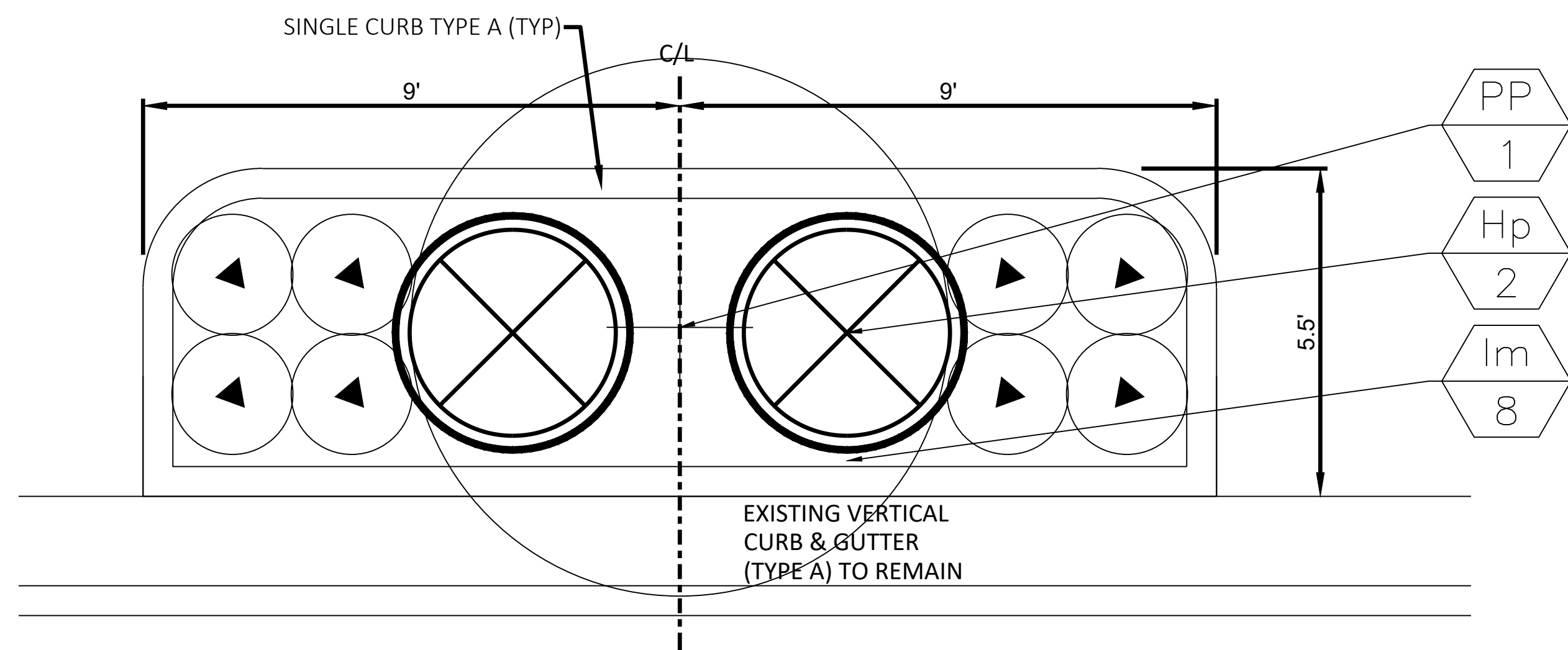

BUMP OUT DETAIL - ALT 2



Acacia aneura



Leucophyllum langmaniae



Dalea greggii

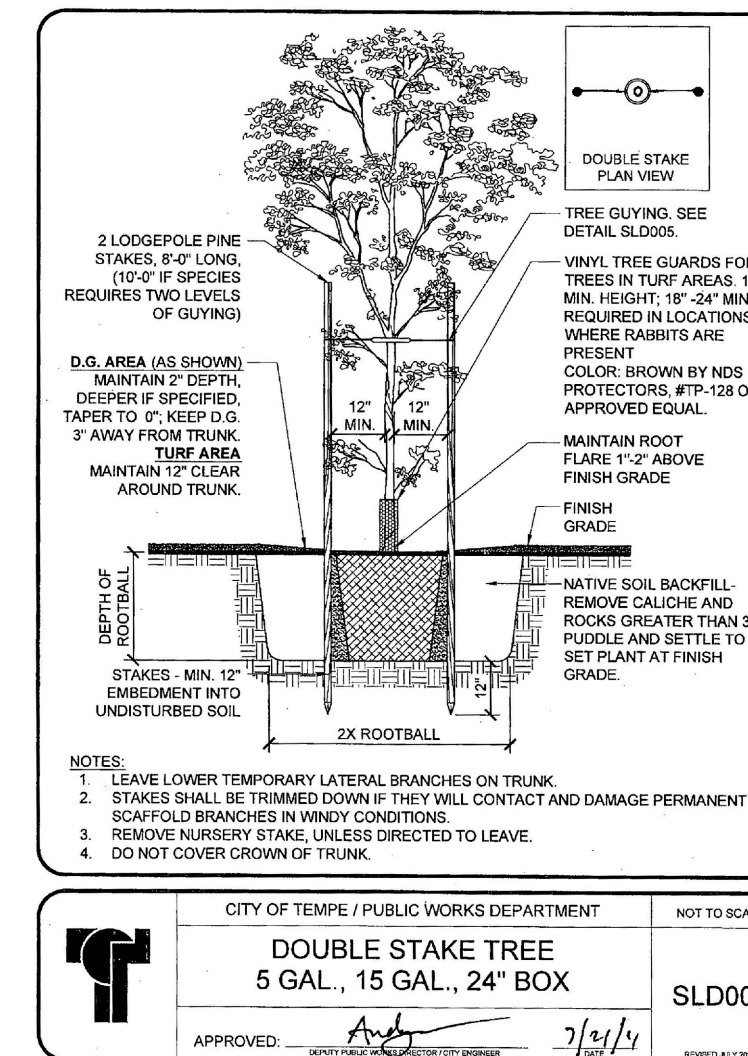

CITY OF TEMPE / PUBLIC WORKS DEPARTMENT NOT TO SCALE
DOUBLE STAKE TREE
 5 GAL., 15 GAL., 24" BOX
 SLD001
 APPROVED: [Signature] 7/24/11

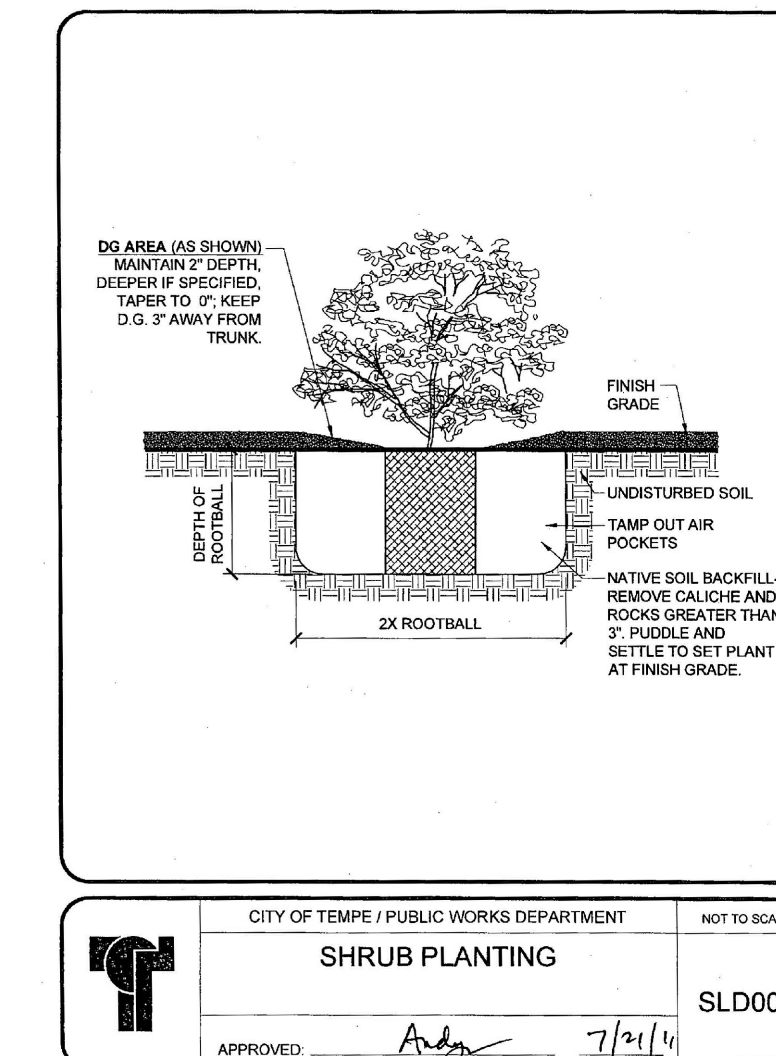

CITY OF TEMPE / PUBLIC WORKS DEPARTMENT NOT TO SCALE
SHRUB PLANTING
 SLD008
 APPROVED: [Signature] 7/24/11

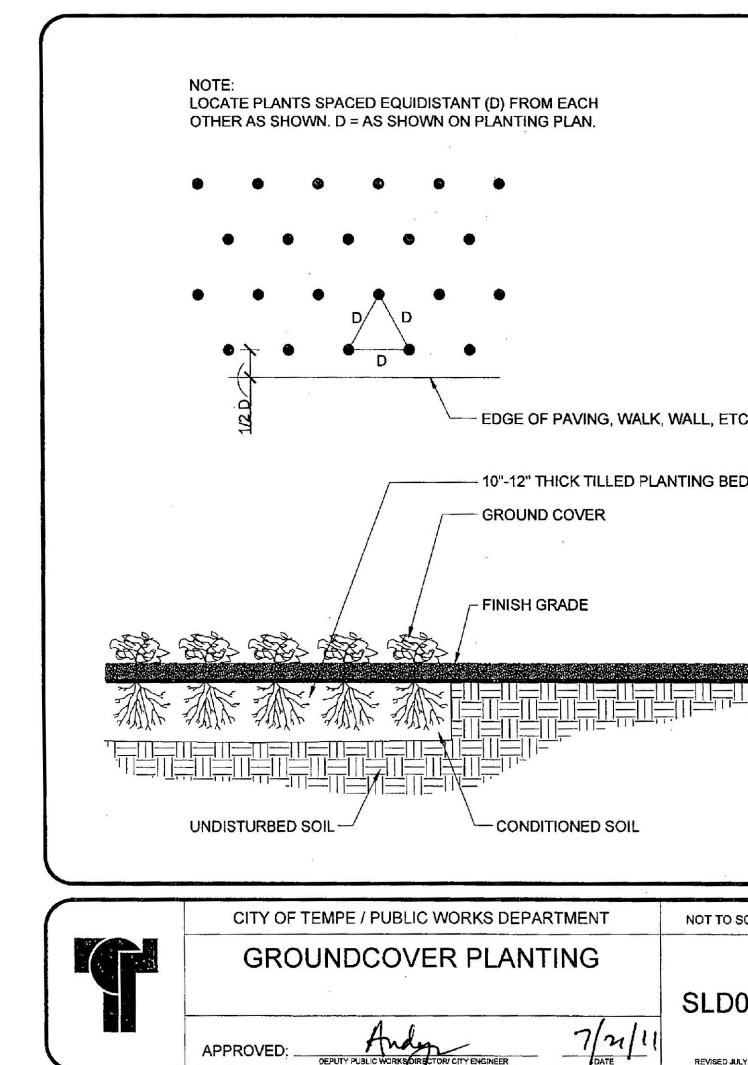

CITY OF TEMPE / PUBLIC WORKS DEPARTMENT NOT TO SCALE
GROUND COVER PLANTING
 SLD011
 APPROVED: [Signature] 7/24/11

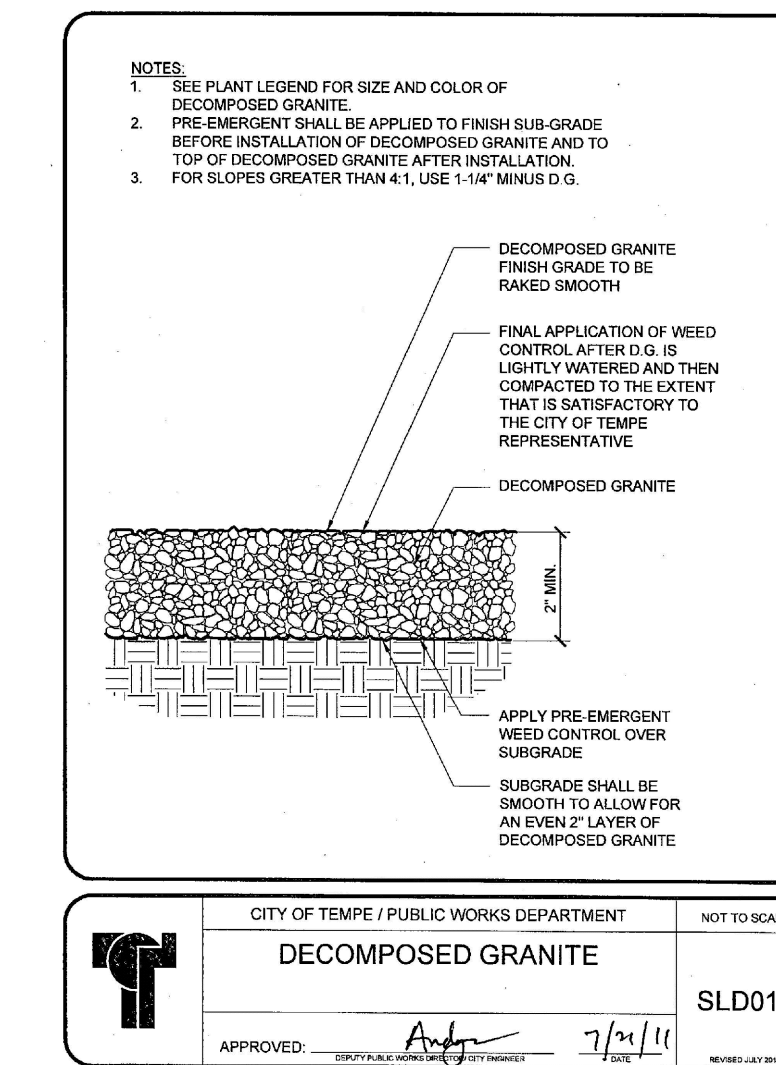

CITY OF TEMPE / PUBLIC WORKS DEPARTMENT NOT TO SCALE
DECOMPOSED GRANITE
 SLD012
 APPROVED: [Signature] 7/24/11



Parkinsonia praecox



Hesperaloe parviflora



Lantana montevidensis

30% REVIEW
 PLANS
 NOT APPROVED FOR
 CONSTRUCTION

Call at least two full working days before you begin excavation.
ARIZONA811
 Arizona Blue Stake, Inc.
 Dial 8-1-1 or 1-800-STAKE-IT (782-5348)
 In Maricopa County: (602) 263-1100

MARK	DATE	DESCRIPTION	BY

DEPARTMENT OF PUBLIC WORKS
 CITY OF TEMPE
 DIVISION OF ENGINEERING
 P.O. BOX 5002, TEMPE, AZ 85280

SURVEYED:	DESCRIPTION	DATE
DESIGNED:	Tempe, Arizona	PROJECT NO.
DRAWN:		
CHECKED:		
SCALE: HORIZ: VERT:		SHT OF

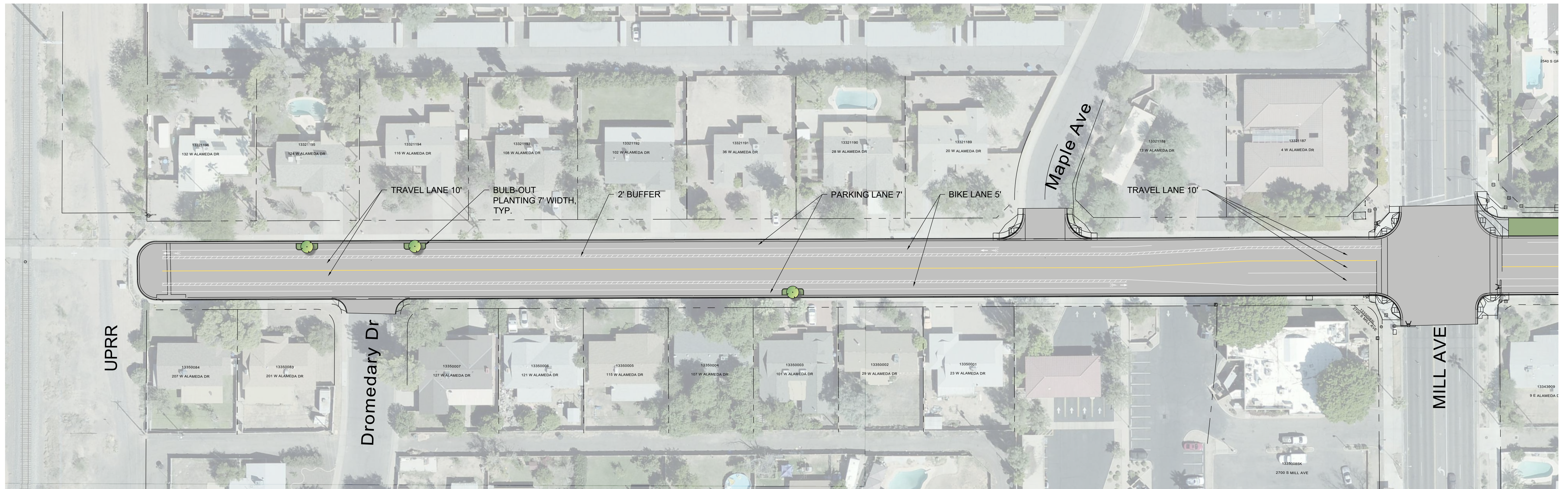

Alameda Drive - Railroad to Mill Avenue

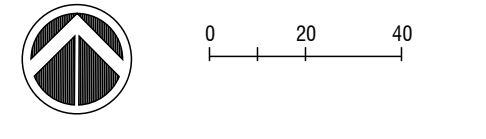

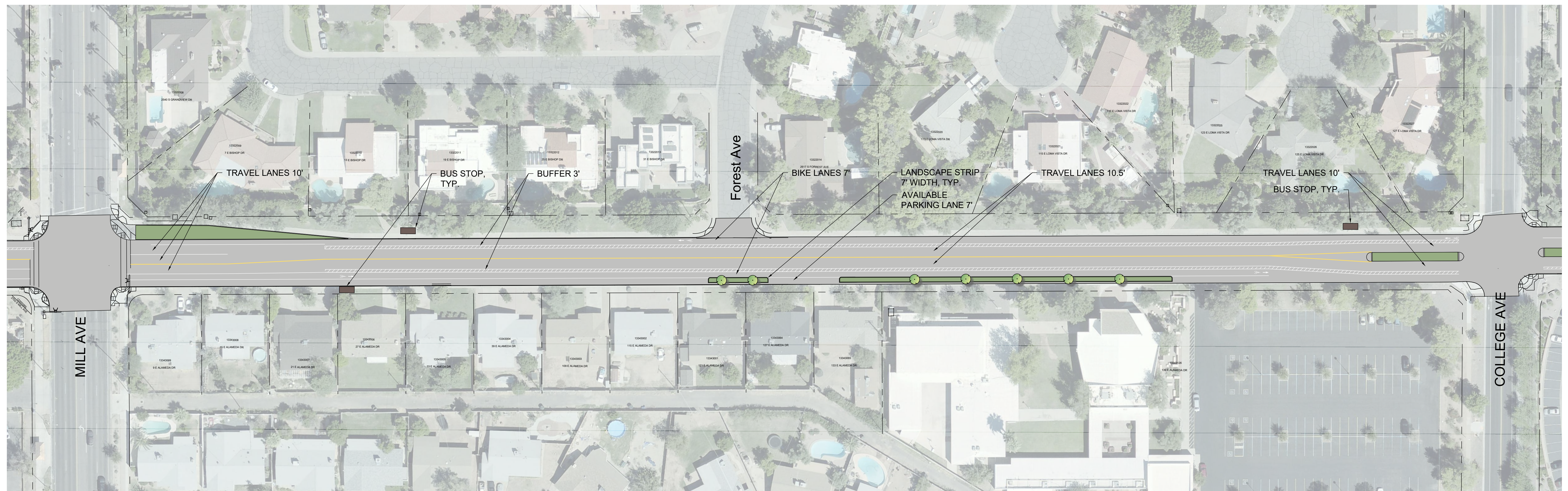

Alameda Drive - Mill Avenue to College Avenue

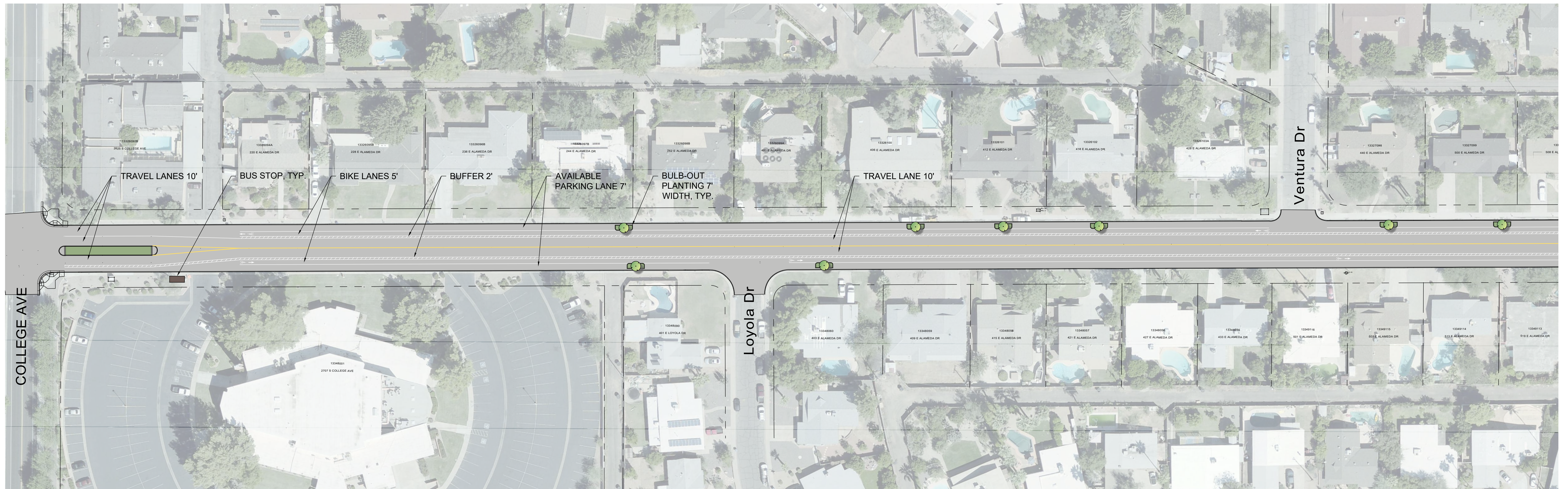

Alameda Drive - College Avenue to Rural Road 1 of 2

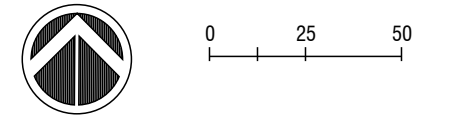

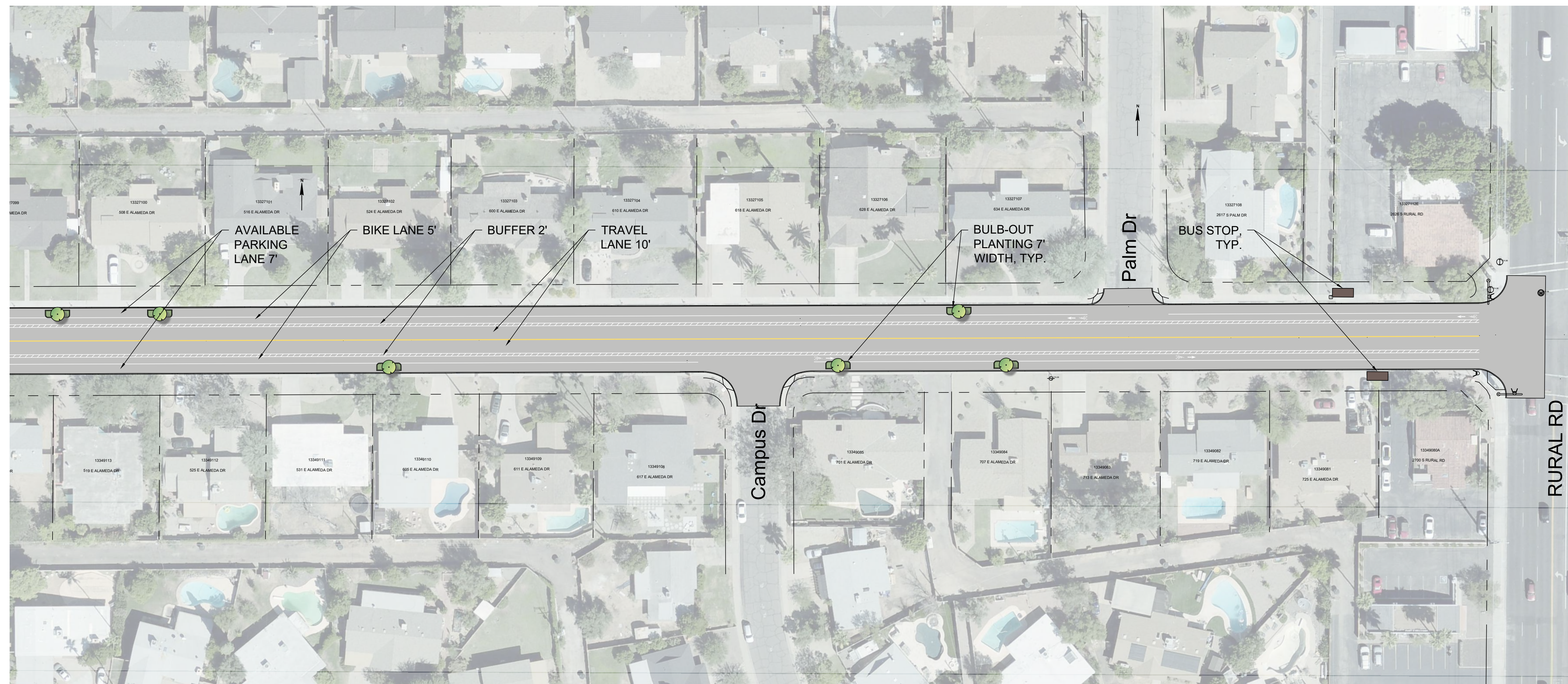

Alameda Drive - College Avenue to Rural Road 2 of 2

