

CITY OF TEMPE

**PUBLIC WORKS DEPARTMENT
ENGINEERING DIVISION**

**STANDARD LANDSCAPE AND IRRIGATION
DETAILS AND SPECIFICATIONS**



Andy Goh

Andy Goh, P.E.

Deputy PW Director/City Engineer

July 2011

Table of Contents
Standard Landscape & Irrigation Specifications

Irrigation System Specifications General

Sprinkler, Irrigation and Standard Landscaping Details.....6
General Requirements.....8
As-Built Drawings.....8
Controller Charts.....9
Operation and Maintenance Manuals.....10
Spare Parts & Equipment.....10
Guarantee.....11

Irrigation System Specification Products

General Piping.....12
Plastic Pipe and Fittings.....12
Copper Pipe and Fittings.....13
Backflow Prevention Units.....14
Pressure Reducing Valves.....14
Wye Strainers.....14
Shut off Valves.....15
Quick Coupling Valves.....16
Remote Control Valves.....17
Automatic Controller Electric.....18
Automatic Controller Solar.....21
Low Voltage Control Wiring.....21

Valves Boxes.....	22
Sprinkler Heads.....	24
Check Valves.....	28
Drip Irrigation.....	28
Sensors.....	30
Basket Strainer.....	31
Booster Pumps.....	31
Miscellaneous Equipment.....	32

Irrigation System Specification Execution

Inspection Schedule.....	33
Water Supply.....	33
Lay out.....	34
Assemblies.....	34
Line Clearance.....	35
Trenching.....	35
Backfilling.....	35
Flushing the System.....	36
Under Existing/Proposed Pavement.....	36
Controllers.....	37
Irrigation Heads.....	37
Adjusting the System.....	38
Coverage Tests.....	38

Tests.....	38
Maintenance.....	39
Completion Cleaning.....	39

Planting Specifications General

Inspections.....	40
Guarantee.....	40

Planting Specification Products

Materials.....	41
----------------	----

Planting Specification Execution

Installation.....	44
Optional Soil Conditioning.....	45
Weed Control Program.....	46
Planting.....	46
Turf.....	47
Pruning.....	48
Clean-up.....	48

Planting Specification Maintenance

Maintenance Periods.....	49
Tree and Shrub Care.....	49
Turf Care.....	51
General Maintenance.....	51

Guarantee.....	52
<u>Hydro-seeding Specification Products</u>	
Materials.....	53
<u>Hydro-seeding Specification Execution</u>	
Installation Procedures.....	53
Hydro-Seeding Application.....	54
<u>Hydro-seeding Specification Maintenance</u>	
Maintenance Periods.....	55
Fertilization.....	55
Weeding.....	55
Minimum Coverage and Acceptance.....	55

SPRINKLER / IRRIGATION DETAILS

- T-701 Pop-Up Sprinkler Rotor Type (4" & 6")
- T-702 Pop-Up Sprinkler Rotor Type (12")
- T-703 Pop-Up Sprinkler Spray Type (4" & 6")
- T-704 Pop-Up Sprinkler Spray Type (12")
- T-705 Root Zone Watering System in Flood Irrigation
- T-706 Root Zone Watering System in Tree Grate
- T-707 Root Zone Watering System for Existing Trees
- T-708 Multi-Outlet Emitter Installed Below Grade
- T-709 Single-Outlet Emitter Installed Below Grade
- T-710 Drip Emitter Tubing Outlet
- T-711 Flexible Drip Tubing Installed Below Grade
- T-712 Flexible Drip Tubing Installed Above Grade
- T-713 Manual Flush Valve Installed in Box
- T-714 Automatic Flush Valve Installed in Box
- T-715 Air/Vacuum Relief Valve Installed in Box
- T-716 Remote Control Valve Installed in Box
- T-717 Drip Remote Control Valve and Pressure Reduction Assembly
- T-718 Ball Valve Installed in Box
- T-719 Gate Valve 2-1/2" and Larger Installed in Box
- T-720 Butterfly Valve Installed in Box
- T-721 Quick Coupler Valve Installed in Valve Box
- T-722 Air Release Valve Installed in Box
- T-723 Pressure Relief Valve Installed in Box
- T-724 Remote Control Valve ID Tag
- T-725 Irrigation Controller in Enclosure
- T-726 Irrigation Controller Wall Mount Interior
- T-727 Flip Top Cabinet
- T-728 Backflow Preventer with Enclosure 2" Diameter & Smaller
- T-729 Backflow Preventer with Enclosure 2" Diameter & Larger
- T-730 Pressure Vacuum Breaker with Enclosure 2" Diameter & Smaller
- T-731 Pressure Vacuum Breaker with Enclosure 2" Diameter & Larger
- T-732 Enclosure Cage for Backflow Preventer
- T-733 Pipe and Wire Trenching
- T-734 Sleeve Trenching
- T-735 Thrust Blocks
- T-736 Pipe Restraint System
- T-737 Wire Connector
- T-738 Two Cable Wire Splice
- T-739 Three Cable Wire Splice
- T-740 Control Wire Pull Box
- T-741 Grounding Grid
- T-742 Grounding Plate

- T-743 Pressure Regulator
- T-744 Flow Sensor
- T-745 Irrigation Satellite Exterior Installation
- T-746 Irrigation Satellite Interior Installation
- T-747 Satellite with CCU Interior Installation
- T-748 Maxicom Satellite System Schematic
- T-749 Maxilink Radio Communication Wiring Diagram
- T-750 Light Powered Controller
- T-751 Backflow Preventer with Solatrol Controller

STANDARD LANDSCAPING DETAILS

- SLD001 Double Stake Tree 5 Gal., 15 Gal., 24" Box
- SLD002 Double Stake Tree on Slope 5 Gal., 15 Gal., 24" Box
- SLD003 Triple Stake Tree 30" Box or Greater
- SLD004 Multi-Trunk Tree 24" Box or Greater
- SLD005 Tree Staking and Guying (Single Trunk)
- SLD006 Tree Staking and Guying (Multiple Trunk)
- SLD007 Root Barrier
- SLD008 Shrub Planting
- SLD009 Shrub Planting on Slope
- SLD010 Vine Planting
- SLD011 Ground Cover Planting
- SLD012 Decomposed Granite
- SLD013 Boulder Installation
- SLD014 Concrete Header

IRRIGATION SYSTEMS SECTION

IRRIGATION SYSTEM SPECIFICATIONS: GENERAL

1. General Requirements:

- a. Permits: Contractor shall obtain all permits required for irrigation installation.

2. As-Built Drawings:

- a. Record accurately on one set of black and white prints (irrigation drawings), all changes in work constituting departures from the original contract drawings. Include changes in both pressure and non-pressure lines.
- b. Upon completion of each increment of work, transfer all such information and dimensions to the prints. Record changes and dimensions in a legible and professional manner. When the drawings are approved, transfer all information to a set of reproducible drawings.
- c. Dimension from two permanent points of reference (monuments, sidewalks, curbs, and pavement). Post information on as-built drawings day-to-day as the work is installed. All dimensions noted on the drawings shall be 1/4 inch in size.
- d. Show dimensional locations and depths of the following:
 - i. Point of connection (P.O.C.).
 - ii. Backflow prevention assembly, master valve and flow sensor.
 - iii. Routing of irrigation pressure mainlines (dimension maximum 100 feet along routing and all directional changes).
 - iv. Ball and butterfly shut-off valves.
 - v. Irrigation control valves.
 - vi. Automatic controller, rain sensors and electrical conduits.
 - vii. Sleeves and pull boxes.
 - viii. Other related equipment (as directed by the Engineer).
- e. Maintain as-built drawings on site at all times. These drawings are subject to inspection at any time.

- f. Make all changes to reproducible drawings in ink (no ballpoint pen). Make changes in a manner equal to the original drawings.
- g. The Contractor shall provide and maintain accurate field data on a red-lined set of Contract drawings, which are to be kept current and submitted as complete at the conclusion of the construction. These record drawings will be used as documentation for progress payments, and upon project completion, for the preparation of as-built file drawings by the architect/engineer. All as-built information shall be on 3 ml double matte black line mylar and shall be 24" x 36" in size. Final payment will not be issued until all record drawings and as-built information are submitted by the Contractor, and certified to be complete by the architect/engineer of record.

3. Controller Charts:

- a. As-built drawings shall be approved by the Engineer before charts are prepared.
- b. Provide two controller charts for each controller supplied, showing the area covered by the automatic controller.
- c. The chart shall be a reproduction of the as-built system drawing. If the controller sequence is not legible when the drawing is reduced, enlarge it to a size that will be readable when reduced.
- d. Charts shall be blackline print with a different transparent color used to show area of coverage for each station.
- e. When completed and approved, hermetically seal the chart between two pieces of plastic, each piece being a minimum of 10 mils thick.
- f. Charts shall be completed and approved prior to final inspection of the irrigation system.
- g. The Contractor shall provide and maintain accurate field data on a red-lined set of contract drawings, which are to be kept current and submitted as complete at the conclusion of the construction. These record drawings will be used as documentation for progress payments, and upon project completion, for the preparation of as-built file drawings by the architect/engineer. All as-built information shall be on 3 ml double matte black line mylar and shall be 24" x 36" in size. Final payment will not be issued until all record drawings and as-built information are submitted by the Contractor, and certified to be complete by the architect/engineer of record.

4. Operation and Maintenance Manuals:

- a. Prepare and deliver to the Engineer, prior to the start of maintenance, all required and necessary descriptive material in complete detail and sufficient quantity, properly prepared in four individually bound copies. Describe the material installed in sufficient detail to permit qualified operating personnel to understand, operate and maintain all equipment. Each manual shall include the following:
 - i. Index sheet stating contractor's address and telephone number.
 - ii. Duration of guarantee period with guarantee forms.
 - iii. List of equipment with names and addresses of manufacturer's local representatives.
 - iv. Complete operating and maintenance instructions on all major equipment.
- b. In addition to the maintenance manuals, provide the maintenance personnel with instructions for major equipment and show written evidence to the Engineer at the conclusion of the work that this service has been rendered.

5. Spare Parts and Equipment:

- a. Prepare and deliver to the Engineer, prior to the start of maintenance, all required spare parts, tools and equipment. Spare parts, tools and equipment shall include the following:
 - i. Two (2) wrenches for disassembly and adjustment of each type of sprinkler head used in the sprinkler system.
 - ii. Two (2) screwdrivers for adjustment of each type of sprinkler head used in the sprinkler system.
 - iii. Two (2) quick coupler keys with 3/4 inch bronze hose bib, bent nose type with hand wheel and two coupler lid keys.
 - iv. One (1) valve box cover key or wrench.
 - v. One (1) 5 foot tee wrench for operating butterfly valves (if used).
 - vi. Six (6) extra sprinkler heads of each size and type used on the project.
 - vii. Six (6) extra drip emitters of each size and type used on the project.

viii. Radio remote operating devices for irrigation system (if specified).

6. Guarantee:

- a. Submit written guarantee, in approved form, that all work showing defects in materials or workmanship will be repaired or replaced at no cost to the City for a period of one (1) year from date of acceptance by the Engineer.
- b. The guarantee form shall be re-typed onto the contractor's letterhead and contain the following information:

Guarantee for irrigation system - **Insert Name of Project**

We hereby guarantee that the irrigation system we have furnished and installed for ** Insert Name of Project ** is free from defects in materials and workmanship, and the work has been completed in accordance with the drawings and specifications, ordinary wear and tear and unusual abuse, or neglect expected. We agree to repair or replace any defects in material or workmanship which may develop during the period of one (1) year from date of acceptance and also to repair or replace any damage resulting from the repairing or replacing of such defects at no additional cost to the City. We shall make such repairs or replacements within a reasonable time, as determined by the City, after receipt of written notice. In the event of our failure to make such repairs or replacements within a reasonable time after receipt of such written notice from the City, we authorize the City to proceed to have said repairs or replacements made at our expense and we will pay for the costs and charges therefore upon demand.

Project Name: _____

Owner: _____

Landscape Architect: _____

Location (Legal Description of Project Property): _____

Signed: _____ Title: _____

By: _____ Date: _____

Address: _____

Telephone/Fax: (_____) _____

IRRIGATION SYSTEM SPECIFICATIONS: PRODUCTS

1. General Piping:

- a. Pressure mainline from point of connection (P.O.C.) through backflow prevention unit: Type K copper.
- b. Mainlines (pressurized) 2 1/2 inch and smaller downstream of backflow unit: Schedule 40 solvent weld P.V.C. unless otherwise noted.
- c. Mainlines (pressurized) 3 inch and larger downstream of backflow unit: Class 315 bell and gasket P.V.C. unless otherwise noted.
- d. Lateral lines (pressurized) 1 1/2 inch and smaller: Schedule 40 solvent weld P.V.C. with primer unless otherwise noted.
- e. Lateral lines (pressurized) 2 inch and larger: Class 315 solvent weld P.V.C. with primer unless otherwise noted.

2. Plastic Pipe and Fittings:

- a. Solvent weld pipe: Extruded of an improved P.V.C. virgin pipe compound featuring high impact strength. Conform to ASTM D-1784 or D-2241 to meet the requirements of cell classification 12454B for pipe. Compound shall have a 2,000 P.S.I. hydrostatic design stress rating.
- b. Rubber gasket P.V.C. pipe: Conform to ASTM D-1784, Type I, Grade I, 2,000 P.S.I. design stress. Standard dimensional ratio for pipe shall be SDR 21 (Class 200). All pipe shall conform to commercial standards CS-256-64 (pressure rated pipe), and National Sanitation Foundation (NSF) testing laboratories. Rubber gaskets shall conform to ASTM 1869.
- c. All pipe and fittings shall bear the following markings: Manufacturer's name, nominal pipe size, schedule or class, pressure rating P.S.I., NSF rating, and date of extrusion.
- d. Make solvent cement joints for plastic pipe and fittings as prescribed by the manufacturer. Including use of primer on all PVC fittings regardless of size.
- e. All P.V.C. slip fittings shall be Schedule 40.
- f. All fittings: Injection molded of an approved P.V.C. fitting compound featuring high tensile strength, high chemical resistance, and high impact strength. Fittings shall conform to ASTM D-1784, and meet the

requirements of cell classification 12454B. Where threads are required in plastic fittings, these shall be injection molded also.

Type: Dura Plastic Products, Spears or approved equal.

- g. Rubber Gasket Fittings: Fittings shall be ductile iron deep bell type. Fittings shall be constructed of grade 65-45-12 ductile iron in accordance with ASTM A-536. Fitting gaskets shall be rubber in accordance with ASTM F-477. All ductile iron fittings shall be manufactured with exterior lugs and be fitted with a joint restraint system.

Type: Harco Ductile Iron Fittings or approved equal.
Leemco Joint Restraint System or approved equal.

- h. All threaded nipples: Standard weight Schedule 80, with molded threads.
- i. All threaded fittings: Use 3/4-inch size Teflon tape.
- j. Reclaimed water pipe: Pipe shall be extruded of an improved P.V.C. virgin pipe compound featuring high impact strength. Confirm to ASTM D-1784 or D-2241 to meet the requirements of cell classification 12454B for pipe. Compound shall have a 2,000 P.S.I. hydrostatic design stress rating. Reclaimed water pipe shall be color coded purple with the words "CAUTION - RECLAIMED WATER" printed in black letters on two sides of the pipe. Reclaimed water pipe shall use standard white Schedule 40 P.V.C. fittings as described above.

Type: Alertline, Water Warn or approved equal.

- k. Ultra-Violet Resistant (U.V.R.) pipe: Pipe shall be extruded of an improved P.V.C. virgin pipe compound featuring high impact strength. Confirm to ASTM D-1784 or D-2241 to meet the requirements of cell classification 12454B for pipe. Compound shall have a 2,000 P.S.I. hydrostatic design stress rating. U.V.R. water pipe shall be manufactured using a process and/or ingredients proven to resist weakening or corrosion by ultra-violet radiation. Pipe shall be color-coded brown. U.V.R. water pipe shall use Schedule 40 P.V.C. fittings manufactured of the same material or process as the U.V.R. pipe on which they are used.

Type: Pipe: Sun Stop, Solar Guard or approved equal.
Fittings: Dura or approved equal.

3. Copper Pipe and Fittings:

- a. Copper Pipe shall be Type K, hard tempered, ASTM B88, with fittings of wrought solder joint type in accordance with ANSI B16.22.

Type: Fittings: Nibco or approved equal.

- b. Solder joints with silver solder: 45% silver, 15% copper, 16% zinc, 24% cadmium and solidus as 1125 degrees F, and liquids at 1145 degrees F., conforming to ASTM B206 and FS QQB-655C.

4. Backflow Prevention Units:

- a. Backflow prevention unit shall be the size indicated on the irrigation plans.
- b. Backflow prevention units shall be approved by the Foundation for Cross-Connection Control and Hydraulic Research at the University of Southern California.
- c. Backflow prevention units shall be the reduced pressure principle (RP) or pressure vacuum breaker (PVB) type.

Type: R/P: Febco 825Y, 825YA, 880 Master Series no known equal.
PVB: Febco 765 no known equal.

- d. Backflow assemblies shall be installed using copper ells, unions and nipples.
- e. Backflow device enclosure shall be constructed of stainless steel #9 expanded metal with an angle iron frame. Enclosure shall be bolted to a concrete pad using galvanized steel hardware. Enclosure shall have a hinge on one end that allows for removal of the enclosure for backflow service.

Type: V.I.T. Strong Box or approved equal.

5. Pressure Reducing Valves:

- a. Pressure reducing valve shall be the size indicated on the irrigation plans.
- b. Pressure reducing valve shall be of bronze and stainless steel construction and be adjustable from 25 P.S.I. to 125 P.S.I.

Type: Wilkins 500HLR or approved equal.

6. Wye Strainers:

- a. Wye strainer shall be the size indicated on the irrigation plans.
- b. Wye strainer shall be of bronze construction with a stainless steel or Monel screen element. Wye strainer shall have a standard filtration size of 80 mesh.

Type: Wilkins 100YSBR or approved equal.

7. Shut off Valves:

a. Ball Valve:

- i. Ball valves 2 inch and smaller shall be the size indicated on the irrigation plans.
- ii. Ball valves shall have a one-piece body constructed of 600-lb. WOG Bronze material conforming with ASTM B-584 alloy 844. Ball valve shall have a vented ball with a blowout proof system. Ball valves shall have a working pressure of not less than 150 P.S.I. and shall conform to AWWA standards.

Type: Hammond 867, Nibco 560, Wilkins 850 or approved equal.

b. Butterfly Valve:

- i. Butterfly valves 2 1/2 inch and larger shall be the size indicated on the irrigation plans.
- ii. Butterfly valves shall have a one-piece body constructed of cast iron and stainless steel stem. Butterfly valve shall have a ductile iron, porcelain enamel coated disc. Butterfly valves shall be equipped with Vanstone flange adapters and a 2-inch square operating nut. Butterfly valves shall have a working pressure of not less than 150 P.S.I. and shall conform to AWWA standards.

Type: Centerline, Matco, Nibco or approved equal.

c. Gate Valve:

- i. Gate valves 2 1/2 inch and larger shall be the size indicated on the irrigation drawings.
- ii. Gate valves shall have a one-piece body, bonnet, gate and stem constructed of 600-lb. WOG Bronze material conforming with ASTM B-584 alloy 844. Gate valves shall have a working pressure of not less than 150 P.S.I. and shall conform to AWWA standards.

- Type: Nibco or approved equal.
- d. Angle Valve (For Remote Control Valve Assemblies):
- i. Angle valves shall be the size indicated on the irrigation plans.
 - ii. Angle valves shall have a body constructed of cast bronze, stem and cross handle. Angle valves shall have a working pressure of not less than 150 P.S.I. and shall conform to AWWA standards.

Type: Champion 200 or approved equal.

- e. Install valves in planting areas and according to the construction details. Only one valve per box will be allowed. Align valve boxes at right angles to adjacent hardscape whenever possible. Where several valve boxes are located in the same area, arrange them in a uniform and orderly fashion. Valve boxes shall be installed with an eight (8) inch deep layer of 3/4 inch crushed gravel at the base of the box.
- f. When grouped together, allow a minimum of 12 inches between valves. The valves shall be installed in valve boxes which will have enough room on all sides of the valves to allow repair personnel to completely re-construct the valves without removing the valve box.

8. Quick Coupling Valves:

- a. Quick coupler valves shall be the size indicated on the irrigation plans.
- b. Quick coupler valve shall have a body constructed of red brass with a wall thickness guaranteed to withstand normal working pressure of 150 P.S.I. without leakage, with female threads opening at base. Quick coupler valve shall have a hinge cover constructed of red brass with a leather like vinyl cover bonded to it in such a manner that it becomes a permanent type of cover. Quick couplers used with potable water shall have vinyl covers yellow in color. Quick couplers used with reclaimed water shall have vinyl covers purple in color with the appropriate reclaimed water warnings in English and Spanish, as well as the international "Do Not Drink" symbol.

Type: Potable Water: Rain Bird 44LRC or approved equal.
Reclaimed Water: Rain Bird 44NP or approved equal.

- c. Quick coupler valve shall be operated only with a special connecting device known as a quick coupler key, designed for that purpose. Quick coupler key is inserted into the valve and a positive, watertight connection shall be made between coupler key and valve.

Type: Rain Bird 44K or approved equal.

- d. Quick coupler assembly shall be a contractor assembled swing joint consisting of three (3) Marlex street ells and a 12-inch long schedule 80 nipple. A single street ell shall be used at the connection to the mainline fitting and two street ells shall be used at the quick coupler end of the swing joint. Assembly shall be 1-inch size to match the inlet size of the quick coupler valve. A rebar stabilizing rod and two (2) stainless steel clamps shall be used to secure the quick coupler.
- e. Install valves in planting areas and according to the construction details. Only one valve per box will be allowed. Align valve boxes at right angles to adjacent hardscape whenever possible. Where several valve boxes are located in the same area, arrange them in a uniform and orderly fashion. Valve boxes shall be installed with an 8-inch deep layer of 3/4 inch crushed gravel at the base of the box.
- f. Locate all quick coupling valves within 12 - 18 inches of walks, curbs, header boards, or paved areas where applicable. Locate quick coupler valves inside shrub and ground cover areas when ever possible. Quick coupling valves shall be installed such that the valve top will be 3-inches below the lid of the valve box.

9. Remote Control Valves:

- a. Remote control valves shall be the size indicated on the irrigation plans.
- b. The remote control valve shall be normally closed 24 VAC solenoid actuated globe pattern, spring-loaded diaphragm type. The valve shall be pressure rated up to 200 P.S.I. at 150 degrees F.
- c. The valve shall have a 600 pound test fabric reinforced rubber diaphragm assembly with self-cleaning stainless steel screen.
- d. Remote Control Valve: The body and bonnet shall be brass and the valve shall have a stainless steel control / shut-off stem and manual operator.

Type: RCV: Rain Bird GB series, Rain Bird EFB-CP series or approved equal.

- e. Drip Remote Control Valve: The body and bonnet shall be fiberglass reinforced nylon and the valve shall have a brass control / shut-off stem and manual operator.

Type: Rain Bird DV-100 series or approved equal.

- f. All remote control valves shall have a bronze angle type shut off valve installed as part of the valve assembly immediately upstream of the control valve.
- g. The valve shall provide for all internal parts to be removable from the top without disturbing the valve installation.
- h. Solenoid shall be corrosion-proof and constructed of stainless steel molded in epoxy to form one integral unit, 24 volt AC watt maximum holding milliamp in-rush, current: 0.41 amp. (9.9 VA), holding current: 0.23 amp. (5.5 VA).
- i. Solenoids for solar powered controllers shall be latching type as manufactured by the same manufacturer as the solar powered controller. Latching solenoids shall be compatible with the approved remote control valves.
- j. Install valves in planting areas and according to the construction details. Only one valve per box will be allowed. Align valve boxes at right angles to adjacent hardscape whenever possible. Where several valve boxes are located in the same area, arrange them in a uniform and orderly fashion. Valve boxes shall be installed with an 8-inch deep layer of 3/4 inch crushed gravel at the base of the box and no more than six valves per valve group.
- k. When grouped together, allow a minimum of 12 inches between valves. The valves shall be installed in valve boxes which will have enough room on all sides of the valves to allow repair personnel to completely re-construct the valves without removing the valve box.

10. Automatic Controller (Electric):

- a. Controller shall be programmable for various schedules with the following features:
 - i. The irrigation system controller shall be a microprocessor based/micro electronics solid state type, capable of fully automatic or manual operation of the system.
 - ii. The controller shall operate on a minimum of 120 volts AC power input and be capable of operating up to four 5.5 VA 24 volt AC electric remote control valves at one time. The controller shall have a reset circuit breaker to protect it from power overload.

- iii. The controller shall have independently programmable stations. The controller programming schedule shall be based on a variable 7-day cycle. Each station shall have the capability of being programmed to automatically start up to four (4) times per day. Station timing shall be variable from 1 to 99 minutes in 1-minute increments or for 0.1 to 9.9 hours in 0.1-hour increments. Controller station operation shall be sequential to avoid overlapping operation. The controller shall have a water budgeting mode to allow simultaneous increasing or decreasing of watering time for all stations.
 - iv. During operation the controller shall provide a monitoring readout indicating station in operation and time remaining. The controller shall have a 12-hour AM/PM or 24 hour clock.
 - v. The controller shall have a master valve/remote pump start circuit for use with a master valve to pressurize system when the irrigation cycle starts, or to activate a remote pump start relay, to run the pump during the irrigation cycle.
 - vi. The controller shall be capable of being operated manually at any time. A manual "single station" operation for programmed time or new time setting shall be possible without affecting the original program.
 - vii. The controller shall have a factory preset backup program for standby operation in the event of program loss and a rechargeable battery backup to maintain program during power loss.
 - viii. The controller shall have non-volatile memory or battery back-up with batteries that are continually charged by the controller.
- b. Irrigation controller shall be a satellite type controller compatible with either Rain Bird Maxicom central control systems.
- Type: Maxicom: ESP-SAT-LINK or approved equal.
- c. Outdoor Automatic Controller Enclosure:
- i. All automatic sprinkler controllers installed on the outside of a building shall be mounted within a stainless steel vandal resistant automatic controller enclosure.
 - ii. The outdoor automatic controller enclosure shall be of appropriate size to adequately house the specified controller and all required

central control equipment. Lockable hinged doors shall be equipped with full a length stainless steel gasket hinges.

- iii. Inside controller enclosure to have one circuit with full time 120 VAC GFCI type outlet and 120 VAC to the controller with on/off switch and a pigtail connection for remote control use.
- iv. Controller shall be grounded per the uniform building codes and the controller installation detail.

Type: Strong Box or approved equal.

d. Indoor Automatic Controller Enclosure:

- i. All automatic sprinkler controllers installed on the inside of a building shall be mounted within a wall mounted cold rolled steel vandal resistant automatic controller enclosure.
- ii. The indoor automatic controller enclosure shall be of appropriate size to adequately house the specified controller and all required central control equipment. Lockable hinged doors shall be equipped with full a length steel gasket hinges.
- iii. Inside controller enclosure to have one circuit with full time 120 VAC GFCI type outlet and 120 VAC to the controller with on/off switch and a pigtail connection for remote control use.
- iv. Control wires to be routed to control valves from controller through a 3-inch electrical conduit and sweep through the floor of the building.
- v. Controller shall be grounded per the uniform building codes and the controller installation detail.

Type: Strong Box or approved equal.

e. Controller Accessories:

- i. The electrical power for the irrigation controller shall be provided by the Electrical Contractor. Landscape contractor is responsible for final hook-up of the controller.
- ii. The automatic controller shall be wired with a pigtail to allow for the use of a radio remote activation device. Pigtail is to be manufactured by the manufacturer of the radio remote device.

- iii. If the irrigation drawings indicate that a radio remote is to be provided, the Landscape Contractor shall provide the radio transmitter and the receiver to the City.
- iv. The radio remote device shall allow for the operation of all controller stations from a distance of up to one mile from the controller. The radio remote device shall be furnished inside a plastic carrying case with battery charger.

Type: Rain Master or approved equal.

11. Automatic Controller (Solar):

- a. The solar powered controller shall require no AC electrical power to function. The solar powered controller shall generate sustaining power using only ambient light without the use of external solar panels.
- b. The controller shall operate on minimum light requirements and shall be able to function properly even in shady conditions.
- c. All programming of the controller shall be performed using only four buttons and a self-guided menu.

Type: Solatrol Leit 4000 or approved equal.

12. Low Voltage Control Wiring:

- a. Connections between the controller and remote control valves shall be made with direct burial AWG-UF type wire, installed in accordance with valve manufacturer's wire chart and specifications.
- b. Wiring shall be installed adjacent to the mainline whenever possible and shall never be installed above or below the pipe.
- c. Where more than one wire is placed in a trench, the wiring shall be taped together using black electrical tape at intervals of 10 feet.
- d. All splices shall be made using sealed waterproof connectors. Waterproof connectors shall have a two piece body, copper crimp sleeve, and water proof sealant.

Type: Rain Bird Pen-Tite, Dri-Splice, Snap-Tite or approved equal.

- e. An expansion curl shall be provided within three (3) feet of each wire connection and at all directional changes. Expansion curls shall be sufficient length at each splice connection at each electric control valve, so

that in case of repair, the valve bonnet may be brought to the surface without disconnecting the control wires. Control wires shall be laid loosely in the trench without stress or stretching of control wire conductors. A two (2) foot expansion loop shall be located every 100 feet on continuous wire runs.

- f. Sizing of wire shall be in accordance with irrigation drawings and manufacturer's recommendations in no case shall the diameter of the wire be less than #14 size.
- g. Use continuous wire between controller and remote control valves. Under no circumstances shall splices exist without prior approval. Any splices allowed shall be installed in a pull box.
- h. All control wires shall be black or red in color. When more than one controller is installed use a different color wire for each controller.
- i. All common wires and only common wires shall be white in color. When more than one controller is installed use white colored wire with a different color stripe for each controller. Color of the stripe shall match the color of the control wire.
- j. Flow sensor wires shall be #14 gauge as part of a two pair shielded cable. Cable shall be direct burial type.
- k. Two extra wires shall be provided for each valve in an isolated area, and or each group of five valves. In the group of five valves, the extra wire shall be extended to the farthest valve in the group. All extra wires and only extra wires shall be orange in color. The extra wires shall be looped up into each valve box, and made visible for easy future use.
- l. All wire sleeves shall have a pull rope remaining. Mark each sleeve for future use with a score mark on the adjacent concrete curb. All wire sleeves shall extend at least 24 inch past the edge of the paving. All wire sleeve ends shall be sealed using aerosol foam. All wire sleeves shall be Sch. 40 PVC sized at twice the diameter of the wire bundle carried or 2-inch minimum.

13. Valve Boxes:

- a. Round valve boxes shall be 10-inch diameter x 10-1/4 inch high constructed of rigid polyolefin, chemically inert plastic, with 6-inch Cl. 160 P.V.C. extension sleeves where required. Valve boxes shall have locking plastic covers. Valve boxes and covers shall be green in turf areas and tan in granite/desert areas unless used with reclaimed water where they

shall be color coded purple and embossed with the required reclaimed water warning statements. Heat brand box lid with appropriate identification letters.

Type: Ametek, Brooks or approved equal.

- b. Rectangular valve boxes shall be 9-1/2 inch wide x 16-inch long x 11-inch high constructed of rigid polyolefin, chemically inert plastic, with valve box extensions where required. Valve boxes shall have locking plastic covers. Valve boxes and covers shall be green in color unless used with reclaimed water where they shall be color coded purple and embossed with the required reclaimed water warning statements. Heat brand box lid with appropriate identification letters and/or numbers.

Type: Ametek, Brooks or approved equal.

- c. Identification letters or numbers shall be 2-inch high and heat branded onto the box cover. Identification shall be as indicated on the detail drawings.
- d. Heat branding shall be accomplished using branding irons specifically designed for this purpose. Heat branding shall not weaken or in any way puncture the valve box cover.
- e. Valve box covers shall be green in color unless directed to be purple in color for use with reclaimed water. Reclaimed water valve boxes shall have appropriate reclaimed water warnings embossed onto the cover in English and Spanish, as well as the international "Do Not Drink" symbol.

Type: Rectangular: Ametek, Brooks or approved equal.

Round: Ametek, Brooks or approved equal.

- f. Valve box covers shall be locking type secured with a 3/8-inch stainless steel bolt, washer and nut.
- g. Valve boxes used for irrigation equipment shall be as follows:
 - i. Round valve boxes shall be used for butterfly valves, quick coupler valves, drip system flush valves, and multiple outlet drip emitters.
 - ii. Rectangular valve boxes shall be used for remote control valves, master control valves, drip control valves, drip pressure regulator/WYE filter assemblies, flow sensors, ball valves, basket strainers, and pull boxes.

- h. Install valve boxes in planting areas and according to the construction details. Only one valve per box will be allowed. Align valve boxes at right angles to adjacent hardscape whenever possible. Where several valve boxes are located in the same area, arrange them in a uniform and orderly fashion. Valve boxes shall be installed with an 8-inch deep layer of 3/4 inch crushed gravel at the base of the box.
- i. When grouped together, allow a minimum of 12-inches between valve boxes.

14. Sprinkler Heads:

- a. Full circle, part circle and variable arc spray sprinkler heads with built-in check valve sprinkler heads:
 - i. The sprinkler body, stem nozzle and screen shall be constructed of heavy-duty plastic.
 - ii. The sealing device shall create no more than one (1) PSI pressure drop at maximum rated pressure and flow.
 - iii. The sprinkler shall have a strong stainless steel retract spring for positive pop down. Pop-up height shall be as indicated on the irrigation drawings and no less than 4 inches.
 - iv. The sprinkler shall have a screen under the nozzle to protect it from clogging and for easy removal for cleaning and flushing system.
 - v. Pop-up sprinklers shall be equipped with a built in anti-drain valve capable of holding water within the sprinkler head from up to 10 feet of elevation change. The check valve equipped pop-up sprinkler shall be identified on the cap as being so equipped.
 - vi. The sprinkler shall have a matched precipitation rate (MPR) plastic nozzle with an adjusting screw capable of regulating the radius and flow.
 - vii. MPR nozzles: The plastic nozzles shall have matched precipitation rates across sets (8 feet, 10 feet, 12 feet, and 15 feet). The spray nozzles shall have female thread configuration for use on the 1800 series sprinkler and the PA-8S plastic shrub adapter.
 - viii. Variable arc nozzle: The adjustable nozzle shall have a center collar which twists easily to increase or decrease arc setting. The flow shall adjust with the arc setting to maintain matched

precipitation with other MPR nozzles and other arc settings. The adjustable range shall be 0 to 360 degrees.

- ix. Stream Spray nozzles: The plastic nozzles shall have matched precipitation rates within sets (16 feet and 20 feet). The spray nozzles shall have female thread configuration for use on the 1800 series sprinkler and the PA-8S plastic shrub adapter.

Type: Pop-up: Rain Bird 1800-SAM series or approved equal.
Shrub Adapter: Rain Bird PA-8S series or approved equal.

- b. Full circle, part circle and variable arc pressure regulating spray heads and built-in check valve sprinkler heads:
 - i. The sprinkler body, stem nozzle and screen shall be constructed of heavy-duty plastic.
 - ii. The sealing device shall create no more than one (1) PSI pressure drop at maximum rated pressure and flow.
 - iii. The sprinkler shall have a strong stainless steel retract spring for positive pop down. Pop-up height shall be as indicated on the irrigation drawings and no less than 4-inches.
 - iv. The sprinkler shall have a screen under the nozzle to protect it from clogging and for easy removal for cleaning and flushing system.
 - v. The sprinkler shall be equipped with a built in pressure regulating device capable of regulating an inlet pressure of 35 - 70 PSI to 30 PSI for proper operation of the spray head. At inlet pressures of less than 35 PSI the pressure loss through the regulating device shall be no more than 6 PSI. The pressure regulating device shall be constructed of stainless steel springs and heavy duty plastic parts.
 - vi. Pop-up sprinklers shall be equipped with a built in anti-drain valve capable of holding water within the sprinkler head from up to 10 feet of elevation change. The check valve equipped pop-up sprinkler shall be identified on the cap as being so equipped.
 - vii. The sprinkler shall have a matched precipitation rate (MPR) plastic nozzle with an adjusting screw capable of regulating the radius and flow.
 - viii. MPR nozzles: The plastic nozzles shall have matched precipitation rates across sets (8 feet, 10 feet, 12 feet, and 15 feet). The spray

nozzles shall have female thread configuration for use on the 1800 series sprinkler and the PA-8S plastic shrub adapter.

- ix. Variable arc nozzle: The adjustable nozzle shall have a center collar which twists easily to increase or decrease arc setting. The flow shall adjust with the arc setting to maintain matched precipitation with other MPR nozzles and other arc settings. The adjustable range shall be 0 to 360 degrees.
- x. Stream Spray nozzles: The plastic nozzles shall have matched precipitation rates within sets (16 feet and 20 feet). The spray nozzles shall have female thread configuration for use on the 1800 series sprinkler and the PA-8S plastic shrub adapter.

Type: Pop-up: Rain Bird 1800-PRS series or approved equal.
Shrub Adapter: Rain Bird PA-8s-PRS series or approved equal.

- c. Full circle or adjustable arc pop-up medium range stream rotor sprinkler:
 - i. The full circle or adjustable arc circle pop-up stream rotor sprinkler shall be a single nozzle gear drive, capable of covering 16 - 55 feet radius at 20 - 60 PSI with a discharge rate of 0.5 - 9.2 GPM. The adjustable arc sprinkler shall have an infinitely adjustable arc of coverage from 1 degree to 360 degrees.
 - ii. The sprinkler case and internal assembly, except for the bearing spring, wiper seal and bearing washers, shall be constructed of durable plastic. All pop-up heads installed in turf areas to have a rubber cover.
 - iii. The sprinkler shall have an adjustable diffuser pin for distance and distribution control.
 - iv. The sprinkler shall have a strong stainless steel retract spring for positive pop down. Pop-up height shall be as indicated on the irrigation drawings and no less than 3-1/2 inches.
 - v. The sprinkler shall have a minimum 3/4 -inch bottom inlet with a plastic screen to protect nozzle from clogging. The case shall have a sturdy, reinforced rib design with flange.
Types: Hunter Institutional series. I-20, I25 or approved equal.
- d. Full circle or adjustable arc pop-up large range stream rotor sprinkler:
 - i. The full circle or adjustable arc circle pop-up stream rotor sprinkler shall be a single nozzle gear drive, capable of covering 40 - 74 feet

radius at 40 - 90 PSI with a discharge rate of 3.8 - 27.5 GPM. The adjustable arc sprinkler shall have an infinitely adjustable arc of coverage from 1 degree to 360 degrees.

- ii. The sprinkler case and internal assembly, except for the bearing spring, wiper seal and bearing washers, shall be constructed of durable plastic. Riser shall be constructed of plastic encased in a stainless steel sleeve. All pop-up heads installed in turf areas to have a rubber cover.
- iii. The sprinkler shall have an adjustable diffuser pin for distance and distribution control.
- iv. The sprinkler shall have a strong stainless steel retract spring for positive pop down. Pop-up height shall be as indicated on the irrigation drawings and no less than 3-1/2 inches.
- v. The sprinkler shall have a minimum 1 inch bottom inlet with a plastic screen to protect nozzle from clogging. The case shall have a sturdy, reinforced rib design with flange.

Types: Hunter Institutional series I-25 Plus, I-40, I42 or approved equal.

e. Bubblers:

- i. Tree Bubblers: The bubbler heads shall be pressure compensating full circle units constructed out of heavy-duty plastic. The bubbler shall have a screen under the body to protect it from clogging. Bubblers shall have preset discharge rate of 0.25 - 1.0 GPM. Bubbler shall be pressure compensating between 20 - 90 PSI.

Type: Rain Bud 1400 series or approved equal.

- ii. Tree bubblers to be installed inside 4-inch diameter x 36-inch long perforated drain pipe. A rubber drain cap top shall be secured on the top of the 4-inch pipe with a stainless steel hose clamp.
- iii. Shrub Stream Bubblers: The shrub stream bubblers shall be nozzles constructed out of heavy duty plastic, configured for use on the 1800 series sprinkler and the PA-8S plastic shrub adapter.

Type: Rain Bud 5-B series or approved equal.

15. Check Valves:

- a. Provide check valves and/or anti-drain valves as may be required by the Engineer to prevent drainage of irrigation water from sprinkler system due to changes in elevation.
- b. Swing Check Valve: Where water source is at the bottom of slope swing check valves are to be used. Swing check valves shall be constructed of heavy-duty plastic and stainless steel internal parts. Swing check valve shall permit water to flow up slope not down. Install swing check valves in-line as designated on the irrigation drawings. As all sizes may not be available from the manufacturer, use UVR-PVC Sch. 40 reducing bushings to adapt check valve to the line size as long as PVC swing check valve is larger than the line size.

Types: Valcon, KBI, Flow Controls or approved equal

- c. Spring Check Valve (adjustable): Where water source is at the top of slope adjustable spring check valves are to be used. Spring check valves shall be constructed of heavy-duty plastic and stainless steel internal parts. Spring check valve shall be adjustable between 5 - 15 lbs. Install swing check valves in-line and/or on sprinkler heads designated on the irrigation drawings. As all sizes may not be available from the manufacturer, use UVR-PVC Sch. 40 reducing bushings to adapt check valve to the line size as long as PVC spring check valve is larger than the line size.

Types: Valcon, KBI, Flow Controls or approved equal.

16. Drip Irrigation:

- a. Drip Emitters:
 - i. Multiple outlet drip emitter's type constructed of heavy-duty plastic, with 1/2-inch FIPT inlets and outlets for 1/4-inch tubing. Drip emitters shall have a minimum of 6 outlets, be equipped with a plastic filter screen and have tubing outlets directed to the bottom of the unit. Multiple outlet drip emitters shall house 8 interchangeable pressure compensating drip modules. Drip modules shall have discharge rates between 0.5 - 2.0 GPH.
Type: Bowsmith or approved equal.
 - ii. Drip tubing shall be 1/4-inch size constructed of flexible vinyl or PVC materials. Drip tubing shall be compatible with 1/4-inch barbed fittings and emitter outlets.

Type: Rain Bird, Salco or approved equal.

- iii. Drip tubing ends shall be secured using 6-inch long plastic stakes specifically designed to hold 1/4-inch vinyl tubing.

Type: Rain Bird, Salco or approved equal.

- iv. Drip tubing ends shall be covered with a plastic insect cap or diffuser cap specifically designed for use with 1/4-inch vinyl tubing.

Type: Rain Bird, Salco or approved equal

- b. **Pressure Regulators:** Drip system pressure regulators shall be constructed of heavy-duty, heat resistant plastic and stainless steel internal parts. Pressure regulators shall reduce inlet water pressure in the range 35 - 70 PSI to a preset 30 PSI. Pressure regulators shall have FIPT inlet and outlet. Pressure regulator shall be sized equivalent to the drip control valve as indicated on the irrigation drawings.

Type: Rain Bird, Salco or approved equal

- c. **Wye Filters:** Drip system Wye filters shall be constructed of heavy-duty, heat resistant plastic. Wye filters shall have a removable stainless steel or Monel screen or plastic disks filter. Drip system Wye filters shall have an equivalent filtration level of 150 mesh. Wye filters shall have FIPT inlet and outlet. Wye filters shall be sized equivalent to the drip control valve as indicated on the irrigation drawings.

Type: Rain Bird, Salco or approved equal.

- d. **Manual Flush Valve:**

- i. Drip system manual flush valves shall be ball type constructed of heavy-duty plastic. Flush valve shall be quarter turn type with FIPT inlet and outlet. Wye filters shall be 3/4-inch size.
- ii. Drip system flush valve shall be installed with a brass threaded hose adapter, FIPT to MHT (male hose thread). Flush valve to be installed vertically in box to allow for easy attachment of flush hose to valve.

Type: Flush Valve: KBI WLT-7500-T or approved equal.
Adapter: Champion or approved equal.

e. Automatic Flush Valve:

- i. Drip system automatic flush valve shall be constructed of heavy-duty plastic with a rubber diaphragm and a plastic drip emitter. The automatic flush valve shall allow approximately one gallon of water to exit the system before shutting.

f. Air Release Valve:

- i. Drip system air release valve shall be gravity type constructed of heavy-duty plastic. Air release valve shall have an O-ring sealing device that positively seals at 3 PSI and releases air once the water pressure inside the tubing drops below one PSI.
- ii. Drip system air release valve shall be installed in an adapter tee fitting with barbed insert ends using a 3/4-inch x 1/2-inch threaded reducer bushing. Air release valve shall be installed at the highest point of the drip system.

Type: Netafim, Toro/Geoflow or approved equal.

17. Sensors:

a. Flow sensor:

- i. Flow sensor shall be a solid state unit constructed of a Sch. 80 PVC tee fitting, an O-ring sealed epoxy fused sensor housing, and nylon impeller.
- ii. Flow sensor shall be wired to a separate monitoring device wired to the controller. If using Maxicom system, wire the flow sensor to a pulse output transmitter and pulse decoder wired to the CCU. All separate monitoring devices shall be installed inside of the controller enclosure. Flow sensors shall be installed as per the manufacturer's specifications.

Type: Flow sensor: Data Industrial 220 series or approved equal.

Monitor: Data Industrial 800 LARC or approved equal.

Transmitter: Data Industrial 600 or approved equal.

Decoder: Ram Bird DEC-PUL or approved equal.

- b. Rain Sensor: Rain sensor shall be a container catchment type constructed of heavy-duty plastic with epoxy sealed electronics. Sensor shall be installed within a 1/8-inch thick steel vandal resistant enclosure. Rain sensor shall be wired to the controller as per the manufacturer's recommendations. Mount rain sensor either on the side of the controller

enclosure or on the building eave as directed by the Engineer. All exposed rain sensor wire shall be installed inside a 1/2-inch steel electrical conduit painted to match the building on which it is installed.

Type: WCS Ram Guard RG/RG-VR or approved equal.

- c. Install flow sensor in planting areas and according to the construction details. Align valve boxes at right angles to adjacent hardscape whenever possible. Where several valve boxes are located in the same area, arrange them in a uniform and orderly fashion. Valve boxes shall be installed with an 8-inch deep layer of 3/4-inch crushed gravel at the base of the box.

18. Basket Strainer:

- a. Basket strainer shall have a bronze body and cover with a stainless steel basket element with a filtration equivalent of 80 mesh.

Type: Hayward Model 72 Simplex or approved equal.

19. Booster Pump:

- a. Booster pumps shall be a pre-assembled unit provided by a pump supply company routinely building booster pump systems for use with irrigation systems.
- b. Booster pump shall deliver the system water pressure at the specified irrigation volume indicated on the irrigation drawings.
- c. Booster pump shall be a closed coupled end suction centrifugal; cast iron bronze fitted back pull out design with a mechanical seal and an ODP motor.
- d. Booster pump assembly shall have a combination circuit breaker/magnetic starter control panel installed inside a NEMA 4 enclosure with a HOA switch and components to automatically control the booster system.
- e. Booster Pump assembly shall include brass quarter turn ball valves, brass and stainless steel fitted disc type check valves and brass unions. All piping in booster assembly shall be type L copper. Pressure gauges shall be 2-1/2 inch dial type with liquid filled stainless steel case, capable of reading to 150 PSI. Pipe and equipment shall be sized as indicated on the irrigation drawings.
- f. Booster pump enclosure shall be stainless steel with lockable doors and venting. Booster assembly shall be mounted on an epoxy coated channel

steel base plate and secured to a 4-inch thick concrete base using galvanized steel hardware provided by the pump assembly manufacturer.

- g. Electrical requirements for the booster pump shall be as indicated on the irrigation drawings. Electrical power to be provided by the Electrical Contractor. Landscape contractor is responsible for final hook-up to booster assembly and connection to irrigation controller.
- h. Booster pump shall be grounded as per the manufacture's specifications.

20. Miscellaneous Equipment:

- a. **Hose Bibs:** Hose Bibs for quick coupler assemblies shall be constructed of brass bodies, rubber gaskets and a malleable iron handle. Hose bibs shall have a 1-inch FIPT inlet and a 3/4-inch MHT outlet.

Type: Champion B-402 or approved equal.

- b. **Landscape Fabric:** Landscape fabric for valve box assemblies shall be 5.0 oz. weight woven polypropylene weed barrier. Landscape fabric shall have a burst strength of 225 PSI, a puncture strength of 60 lbs. and capable of water flow of 12 gallons per minute per square foot.

Type: DeWitt Pro 5 Weed Barrier or approved equal.

- c. **Thrust Blocks:** Thrust blocking shall be used on all irrigation mainlines 2-inch diameter and larger. Thrust blocks shall be minimum 1 cubic foot of 470-C-2000 concrete. All PVC pipe fittings shall be wrapped with black plastic tape prior to installation of thrust blocks. A pipe restraint system shall be used in lieu of thrust blocks for all bell and gasket pipe.

- d. **Gravel:** All gravel used in valve boxes shall be washed crushed gravel of approximately 3/4-inch size. No pea gravel shall be used.

- e. **J-hooks:** All pipe installed on grade shall be secured to the ground surface using #4 x 18-inch rebar J-hooks. All J-hooks shall be painted with black epoxy paint prior to installation. J-hooks are to be installed a minimum of 8 feet on center and as indicated on the irrigation drawings.

- f. **Stabilizing Rods:** All assemblies requiring stabilization shall be equipped with #4 x 30-inch rebar stabilizer rods. Quantity of stabilizing rods shall be as indicated on the detail drawings.

- g. **Vandal-proof Clamps:** All assemblies requiring stabilization shall be equipped with vandal-proof clamps constructed of stainless steel and be installed with a tool specifically for this purpose. Clamps shall be one time

only use type and not be removable with screwdrivers or wrenches.
Quantity of clamps shall be as indicated on the detail drawings.

- h. Identification tags with numbers are required on all valves.

Type: Christy Tags (yellow background with black lettering) or approved equal.

Christy Tags (Purple background with reclaimed water warnings) or approved equal.

- i. Swing joint assembly shall be a contractor assembled swing joint consisting of three (3) Marlex street ells and a 6-inch long schedule 80 nipple. A single street ell shall be used at the connection to the lateral line fitting and two street ells shall be used at the quick coupler end of the swing joint. Assembly shall be sized per the sprinkler or drip emitter inlet, with a 6-inch minimum lay length.

IRRIGATION SYSTEM SPECIFICATIONS: EXECUTION

1. Inspection Schedule:

- a. Contractor is responsible for notifying the Engineer 48 hours in advance for the job card inspections.
- b. **AS-BUILT DRAWING MUST BE SUBMITTED PRIOR TO FINAL SITE INSPECTION, NO INSPECTION WILL COMMENCE WITHOUT REDLINE AS-BUILT DRAWING APPROVAL.** In the event the contractor calls for an inspection without as-built drawings, without completing previously noted corrections, or without preparing the system for inspection, he shall be responsible for reimbursing the City for the cost of the inspection per the current rate established by the City. No further inspections will be scheduled until this charge has been paid.
- c. When performing the irrigation coverage test, the contractor shall be responsible for having a two-way communication system or sufficient personnel, so that the directions from the inspection area to the controller of the system can be readily accomplished.

2. Water Supply:

- a. Utilize water meter and provide connections to backflow prevention unit per the irrigation drawings and details.

- b. Connections to the existing water meter shall be at the approximate locations shown on the drawings. Minor changes caused by actual site conditions shall be made without additional cost to the City.
- c. The backflow prevention unit shall be tested by a certified backflow prevention technician and its operation certified in writing. Landscape Contractor is to arrange and pay for all testing and certification fees. The original written certification of the backflow prevention unit is to be submitted to the Engineer.

3. Layout:

- a. Lay out irrigation heads and make any minor adjustments required due to differences between site and the drawings. Any such deviations in layout shall be within the intent of the original drawings and approved by the Engineer.
- b. Lay out all irrigation equipment using an approved staking method, and maintain the staking of approved layout.
- c. All layouts shall be approved by the Engineer prior to equipment installation.
- d. Before starting work on irrigation system, determine that work may proceed without disruption of activities of other trades.
- e. The contractor shall carefully check grades to ensure that the area is safe to begin work.
- f. Contractor is responsible for taking all reasonable investigative actions and precautions, when working around any utility system.
- g. Contractor shall be responsible for verification of site conditions and minor revisions as approved by the Engineer to insure 100% irrigation coverage in all areas.

4. Assemblies:

- a. Routing of irrigation lines as indicated on drawings is diagrammatic. Install lines (and various assemblies) to conform to details on plans. Whenever possible, place all irrigation equipment in the planting areas. Irrigation elements drawn in hardscape areas on the plans is for graphic clarity only and are meant to be placed in planting areas.
- b. Do not install multiple assemblies on plastic lines. Provide each assembly with its own outlet.

- c. Install all assemblies specified herein according to the respective detail drawings or specifications, using the best standard practices with prior approval.
 - d. Assemble brass pipe and fittings and plastic pipe and threaded fittings, using Teflon tape, or approved equal applied to the male threads only.
 - e. Install concrete thrust blocking at all changes of direction 45 degrees or greater on all mainline, 2-inch or larger. Install thrust blocks per details. Pipe-restraint system shall be used in lieu of thrust blocks on bell and gasket pipe.
5. Line Clearance:
- a. All lines shall have a minimum clearance of 4-inches from each other and 24-inches from lines of other trades.
 - b. Do not install parallel lines directly over one another.
6. Trenching:
- a. Dig trenches and support pipe continuously on bottom of trench. Lay pipe to an even grade. Pipe shall be snaked from side to side to allow for expansion and contraction. Trenching excavation shall follow layout indicated and as noted. Where lines occur under paved area, these dimensions shall be considered below sub-grade.
 - b. Provide the following minimum covers:

i. Pressure mainlines 3-inches size or greater:	24-inches
ii. Pressure mainlines less than 3-inches:	18-inches
iii. Non-pressure lines (lateral lines):	18-inches
iv. Control wiring:	24-inches
7. Backfilling:
- a. Initial backfill on all lines shall be of a fine granular material, not larger than 1/2 inch diameter.
 - b. Compact backfill to dry density equal to the adjacent undisturbed soil, conforming to adjacent grades without dips, sunken areas, humps, or other irregularities.

- c. In appropriate types of soil, the Engineer may authorize the use of flooding in lieu of tamping.
- d. Under no circumstances shall vehicle wheels be used for compacting soil.
- e. Provide sand backfill a minimum of 4-inches over and under all piping under paved areas, and a minimum of 2-inches on all other piping.
- f. If settlement occurs and subsequent adjustments in pipe, valves, irrigation heads, turf or other plantings, or other construction are necessary, the contractor shall make all required adjustments without cost to the City.

8. Flushing the System:

- a. After all irrigation pipe lines and risers are in place and connected, and prior to installation of irrigation heads, the control valves shall be opened and full head of water used to flush out the system.
- b. Sprinkler heads shall be installed only after flushing of the system has been accomplished to the complete satisfaction of the Engineer.

9. Under Existing and/or Proposed Pavement:

- a. Trenches located under areas where paving, asphaltic concrete or concrete will be installed shall be backfilled with sand and compacted in layers to 95% compaction, using manual or mechanical tamping devices. Trenches for piping shall be compacted to equal the compaction of the existing adjacent undisturbed soil and shall be left in flush with the adjoining grade. The irrigation contractor shall set in place; cap and pressure test all piping under paving prior to paving work.
- b. Piping under existing pavement may be installed by jacking, boring, or hydraulic driving. However, no hydraulic driving will be permitted under asphalt paving.
- c. Provide a minimum cover of 24-inches between the top of the pipe and the bottom of aggregate base for non-pressure piping (laterals) installed under asphaltic concrete paving. Provide a minimum cover of 36-inches between the top of the pipe and the bottom of aggregate base for pressure mainline piping installed under asphaltic concrete paving.
- d. Sleeves shall be two times the diameter of lateral line, mainline, and wire bundle size, and a minimum of 2-inch size. Install separate sleeves for each use.

- e. Under public roads, all mainlines and lateral piping must have a minimum cover of 36-inches from the top of the pipe to the bottom of aggregate base.
- f. Secure permission from the Engineer before cutting or breaking existing pavement. All necessary repairs and replacements shall be approved by the Engineer at no additional cost to the City.

10. Controller:

- a. The contractor shall install a new controller as specified on the irrigation drawings.
- b. Controller shall be installed in the locations indicated on the irrigation drawings and approved by the Engineer.
- c. Contractor shall install separate sleeves for the phone line, control wiring, ground wire and electrical power wires as required.
- d. Install one extra 1-1/4 inch size conduit into the enclosure for future use.

11 Irrigation Heads:

- a. Install irrigation heads as indicated on the irrigation drawings.
- b. Spacing of heads shall not exceed the maximum indicated. In no case shall the spacing exceed the maximum recommended by the manufacturer.
- c. Sprinkler heads in lawn or turf areas shall be elevated to a minimum of 4-inches above grade during installation. Heads along curbs, walks, paving, etc., shall be placed at finish grade. Lower raised irrigation heads within ten days after notification by the Engineer.
- d. Final sprinkler head heights shall be as indicated on the City standard irrigation detail drawings. All sprinkler heads installed adjacent to hardscape features shall be located 6-inches off of the edge of the hardscape feature in ground cover areas and 4-inches from the edge of the hardscape feature in turf areas.
- e. All irrigation heads shall be set perpendicular to finish grades unless otherwise indicated on the plans.

12. Adjusting the System:

- a. The contractor shall flush and adjust all irrigation heads and valves for optimum performance and to prevent over spray onto walks, roadways, buildings, walls and other structures as much as possible.
- b. If it is determined that adjustments in the irrigation equipment or nozzle changes will provide proper and more adequate coverage, make all such changes or make arrangements with the manufacturer to have adjustments made, prior to any planting.

13. Coverage Test:

- a. When the irrigation system is completed, perform a coverage test in the presence of the Engineer to determine if the water coverage for lawn, planting and slope areas is complete and adequate. Coverage must be 100% head to head to be accepted by the Engineer. Furnish all materials and perform all work required to correct any inadequacies of coverage due to deviations from the plans or where the system has been willfully installed as indicated in the drawings; when it is obviously inadequate or inappropriate, without bringing this to the attention of the Engineer. This test shall be accomplished before any plant material is planted (excluding trees).

14. Tests:

- a. All piping under paved areas shall be tested under a hydrostatic pressure of 150 PSI, and approved watertight, prior to the paving operation. Make hydrostatic tests only in the presence of the Engineer. No pipe shall be backfilled until it has been inspected, tested, and approved in writing.
- b. Furnish necessary force pump and all other test equipment.
- c. Test all pressure mainlines under a hydrostatic pressure of 150 PSI for a period of two hours.
- d. All testing shall be approved prior to the installation of remote control valves, quick couplers, or other valve assemblies.
- e. Air pressure check all lines that could weaken or damage any major structures or hardscape, if water were used.

15. Maintenance:

- a. The entire irrigation system shall be under full automatic operation for a period of seven days prior to any planting or hydro-seeding (excluding trees).

16. Completion Cleaning:

- a. Upon completion of the work, make ground surface-level, remove excess materials, rubbish, debris, etc., and remove construction and installation equipment from the premises.

END OF SECTION

PLANTING SECTION

PLANTING SPECIFICATIONS: GENERAL

1. Inspections:
 - a. Inspections shall be made by the Engineer. Contractor shall be on the site when inspections are made. Requests for inspections shall be made at least 48 hours in advance. If the work is not ready for inspection when the inspector arrives, contractor shall pay for the Engineer's visit at current City Rate.
 - b. Inspection is required by the Engineer per inspection job card.
 - c. Any work completed without proper inspection by shall be removed and replaced at no expense to the city.
 - d. All existing remaining trees are to have protective fencing installed at drip lines of the tree. Nothing is to be stored inside this enclosure.
2. Guarantee:
 - a. All trees (5 gallon and larger) shall be guaranteed for a period of one year. All shrubs and other plant materials shall be guaranteed for a period of 90 calendar days. All guarantee periods commence from the time of final acceptance by the Engineer at the completion of the 90 calendar day maintenance period.
 - b. Replace, as soon as weather permits, all dead plants not in vigorous condition as noted during the maintenance period. Said plants shall be maintained for a period of 90 calendar days from the replacement date.
 - c. Plants used for replacements shall be same kind and size as originally planted. They shall be furnished, planted and fertilized as specified and guaranteed within these documents.

PLANTING SPECIFICATIONS: PRODUCTS

1. Materials:

- a. Topsoil: Existing soil on the site shall be used as topsoil for planting purposes when possible, but shall be free of debris, oil, weeds, or other foreign matter. Contaminated soil shall be removed and replaced with acceptable existing soil or imported soil.
 - i. Imported soil shall be sandy textured. Silt plus clay content of this soil shall be not greater than 15% by weight. The boron content of this soil shall be not greater than 1 part per million as measured on the saturation extract. The sodium absorption ratio (SAR) shall not exceed 3.0 milliohms per centimeter at 25 degrees C.
 - ii. In order to ensure conformance, samples of the imported soil shall be submitted to an agronomic soils testing laboratory, approved by the Engineer for analysis prior to use. Results of testing shall be delivered to the Engineer for approval. Soil test are to include analysis and recommendations.
- b. Fertilizers and soil conditioners:
 - i. Organic amendment shall be redwood shavings, fine textured, having actual minimum 100% passing #4 screen. Salinity shall not be higher than 3.5 milliohms per centimeter at 25 degrees C. as measured by saturation extract conductivity.

Type: Scotts Amendment, Terra Products of America "Terra Blend" or approved equal.
 - ii. Commercial fertilizer shall have a minimum of 16% nitrogen, 6% phosphoric acid, and 8% potash. Deliver mixed fertilizer in standard bags, marked with weight, analysis and name of manufacturer. Keep fertilizer in dry storage. Use 15-15-15 fertilizer and ammonium nitrate fertilizer during school season planting.

Type: Best commercial grade or approved equal.
 - iii. Plant tablets shall be pre-formed 7 gram size.

Type: Agriform or approved equal.
- c. Soil Conditioner shall be pelletized gypsum with iron.

Type: Best "soil Buster" or approved equal.

d. Plant materials:

- i. All plant materials shall be healthy, well-developed representatives of their species or varieties, free from disfigurement with well-developed branch and root systems, and certification of nursery inspection that plants are free from all plant diseases and insect infestation.
- ii. Tag plant materials with name and size in accordance with standards of practice recommended by American Association of Nurserymen.
- iii. Size of tree and shrub containers shall be as stated on the planting plan. Container stock shall have grown in containers for at least six (6) months, but not over two (2) years. Samples shall be shown to prove that no root-bound conditions prevail. No container plants that have cracked or broken balls of earth, when taken from containers shall be planted, except upon specific approval.
- iv. Do not prune, prior to delivery, except by specific approval.
- v. Plants shall be subject to inspection for size, variety, condition, latent defects and injuries, at place of growth and at the project site at any time before or during progress of work. Remove rejected plants from the project site immediately and replace it with acceptable material.
- vi. Protect all plants from damage by sun, wind or rain at all times before planting.
- vii. Substitutions will not be permitted; except, when proof is submitted that any plant specified is not obtainable. In this case, a proposal will be considered for use of the nearest equivalent in size or variety with an equitable adjustment of contract price. All substitutions will be subject to the Engineer's approval.
- viii. Plants shall have grown under climatic conditions comparable to those of the project site, unless otherwise specifically approved by the Engineer.

e. Ground Cover:

- i. Ground covers will be hand planted in the areas indicated on the planting plans.

- ii. Ground cover plants shall be grown in flat plants or peat pots as indicated on the plant list. Flat grown plants (rooted cuttings) shall remain in flats until transplanting. The soil in the flat shall contain sufficient moisture so that it will not fall apart when lifting the plants. If plants from peat pots are used, the peat pots shall be protected at all times prior to planting to prevent unnecessary drying of the root ball.
 - iii. Ground covers shall be planted in a triangular pattern evenly spaced unless otherwise noted on the plan. Plant ground covers continuously under all trees and shrubs in the areas designated on the planting plans.
 - iv. Each plant shall be planted with its proportionate amount of soil from the flat or in a peat pot, in a manner that will ensure minimum disturbance of the root system. Hand smooth planting area after planting to provide an even, smooth, final finish grade. To avoid drying out, plantings shall be immediately watered after planting until the entire area is soaked to the full depth of each hole unless otherwise noted on the drawing.
- f. Inorganic Ground Cover (Decomposed Granite):
- i. All decomposed granite shall be as shown in plans and specifications in color.
 - ii. All decomposed granite particles shall be able to flow through a 3/8 inch mesh screen.
 - iii. Finish grade of decomposed granite shall be held to 1 inch below any borders, sidewalks, paths, driveways, curbs etc.
 - iv. All areas to receive decomposed granite shall be treated with a pre-emergent herbicide prior to installation of the granite. The pre-emergent herbicide shall have a six (6) month residual. The same areas shall receive a second treatment of the pre-emergent herbicide at the end of the maintenance period.
- g. Tree ties for use with lodge pole pine stakes or metal tree stakes used in conjunction with sidewalk tree grates shall be contractor assembled and installed with Vinyl Clad Steel Guy Wire passed through 1/2 inch new rubber hose. Trees with two stakes shall be staked perpendicular to the prevailing wind direction.
- h. Tree stakes: Two (2) - 2 inch diameter x 10 foot long lodge pole pine stakes for all five gallon, fifteen gallon and 24 inch box trees. Use three

(3) -2 inch diameter x 10 foot long lodge pole pine stakes (triple stake) for all trees 30 inch box size and larger. Tree stakes shall be pine and pointed at one end.

- i. Staking of trees in sidewalk tree grates to be accomplished with the use of manufactured 1-1/4 inch metal tube stake that is 8 foot in length and has a 6-inch round 1/4 inch steel plate base with opposing 10 inch gussets at the base. The base is to be slotted to fasten to the tree grate. The base plate shall be installed as directed by the City of Tempe representative.
- j. Root Barriers: Where trees are planted within eight (8) feet of curbs, sidewalks or pavement, install a subsurface panel barrier 10 feet long centered on the tree trunk ("Deep-Root" or approved equal).

PLANTING SPECIFICATIONS: EXECUTION

1. Installation:

- a. Site clearance: Clean up and remove from the planting areas weeds and grasses, including roots, and any minor accumulated debris and rubbish before commencing work.
- b. Storage: Secure permission from the City to store plants on the project site, and insure that they are protected from damage by the sun, wind, and construction work.
- c. Finish grading of planting areas. Grading shall be done as indicated on the grading plans and as follows.
 - i. Do not work on the soil when moisture content is so great that excessive compaction will occur, or when it is so dry that dust will form or clods will not readily break up.
 - ii. Remove and dispose of all soil in planting areas that contain any deleterious substance such as oil, plaster, concrete, gasoline, paint, solvents, etc., removing the soil to a minimum depth of six (6) inches or to the level of dryness in the affected areas. The affected soil shall be replaced with native or imported soil as required. The contractor shall be responsible for any damage to installed plants caused by such substances.
 - iii. If an area to be landscaped is not acceptable to the contractor, the contractor shall notify the Engineer, in writing.

- iv. Prior to start of finished grading; loosen all planting areas to a depth of six (6) inches. Finish grades shall allow for addition of soil conditioners.
- v. Make minor grade adjustments as directed by the Engineer.
- vi. Where designated drainage meets an obstruction, warp grades so that no water collects.
- vii. Use water trucks and sprinklers as required to control all airborne dust caused by grading operations.
- viii. Finish grading all planting areas to a smooth and even condition, making certain that no water pockets or irregularities remain. Remove and dispose of all foreign materials, clods and rocks over 1-inch in diameter within 3-inches of surface.
- ix. Provide a grade which, after conditioning and planting, is 1-inch below the tops of curbs and walks in lawn areas and 1-inch below for shrub areas sloping to drain to adjacent roadway, drain swale or catch basin.

2. Optional Soil Conditioning:

- a. Amend all planting areas with a grade of 3:1 or less. Incorporate evenly into the top 6-inch of existing soil (with a rototiller or approved piece of equipment) the following per each 1,000 square feet of planting area.
 - i. 4 cubic yards of soil amendment.
 - ii. 25 lbs. of commercial fertilizer or approved equal.
- b. The above soil conditioning quantities shall be used for bidding purposes only, soil conditions may change drastically from the time these specifications were developed until the actual soil conditioning takes place. Therefore, the contractor shall obtain soil samples at a rate of one per every 25,000 square feet of planted area in the presence of the Engineer. These soil tests shall be conducted by an approved agronomic soils testing laboratory approved by the Engineer. Copies of the soil test shall be provided during the pre-site meeting and verified by the Engineer. The contractor shall add amendments per soils report recommendations for individual planting areas and as approved by the Engineer.
- c. All rocks or unbroken soil clods over 1-inch in diameter brought to the surface shall be removed from the project site.

3. Weed control program: Upon completion of the soil amendment installation and fine grading work perform weed control measures as follows:
 - a. Irrigate all areas designated to be planted for seven days at a schedule required to germinate all weed seed possible.
 - b. Apply weed killer per manufacturer's recommendation and the Engineer's approval and allow efficient time for complete kill of all germinated weeds.
 - c. Repeat step "a" above.
 - d. Repeat step "b" above.

4. Planting shall be completed as follows:
 - a. Determine location of the trees and shrubs by scaling from the planting plan.
 - b. Spot containers, and obtain approval from the Engineer before excavating planting pits.
 - c. Excavate planting pits with vertical sides for all plants. Shrub pits shall be three times the diameter and one times the depth of the root ball. Tree pits shall be three times the diameter and 1 times the depth of the root ball.
 - d. If planting pits are cut with power auger, vertical sides of pit shall be additionally broken with balling bar or spade to interrupt continuous curve influence on root development. All pit sides shall be scarified prior to backfilling.
 - e. Root flares shall be identified and finish grade shall be at the root flare level, especially with trees. Plant material shall be planted in such a way that after settling, the crown of the plant bears the same relation to finish grade that it did to the surface in the container.
 - f. Backfill tree and shrub planting pits with a prepared mix as follows:
 - i. 5 parts native on site soil.
 - ii. 3 parts soil amendment.
 - iii. 5 lbs. commercial fertilizer per cubic yard of mix or approved equal.
 - iv. 5 lbs. gypsum per cubic yard of mix.

- g. Form shallow basin around the edge of planting pits.
 - h. Plant Tablets - 7 gram planting tablets. Provide tablets in the following ratios:
 - i. 1 tablet per ground cover and liners,
 - ii. 2 tablets per gallon plant.
 - iii. 6 tablets per 5 gallon plant.
 - iv. 12 tablets per 15 gallon plant.
 - v. 14 tablets per 24 inch box plant.
 - vi. 16 tablets per 30 inch box tree.
 - vii. 18 tablets per 36 inch box tree.
 - viii. 20 tablets per 48 inch box tree.
 - i. Grade area around plants to finish grades and dispose of excess soil.
 - j. Location for street trees adjacent to any light standards or utility equipment shall be adjusted to maintain a suitable clearance, as approved by the Engineer.
 - k. Install sump drains per details for all trees with slow or poor draining soils per approval of Engineer.
 - l. Install 3-inch perforated pipe vertically along tree root ball to 6-inch below bottom of root ball. Fill with 1/2 inch to 3/4 inch gravel. 15 Gallon trees to have three (3) tubes installed one each at 2:00, 6:00, and 10:00 configurations. 24-inch and larger box trees are to have four tubes installed, one at each corner.
5. Turf:
- a. After turf is installed, irrigate thoroughly to provide good moisture penetration.
 - b. Maintain turf edges adjacent to walks with a mechanical edger in a neat condition until the acceptance of the work.
 - c. Take sufficient measures to ensure the turf against damage resulting from pedestrian traffic. If any type of barrier is used, it shall meet with the

approval of the Engineer. Repairs to all damaged turf will be necessary before acceptance will be made.

- d. Irrigate areas to be sodded prior to installation. Soil shall be moist to a depth of two inches.
- e. Lay sod within twenty four (24) hours after it is delivered. Protect rolls from drying out as necessary.
- f. Unroll sod carefully and place in staggered rows. Tamp each roll against the adjacent strips to eliminate joints and edges.
- g. Trim sod to conform to turf shapes designated on the planting plans.
- h. Roll all sod areas with an approved sod roller no later than twenty four (24) hours after installation. Sod shall be flush with the finish grade of existing walk, curbs, etc. Additional rolling may be required to meet this requirement and Engineer's approval.
- i. Mow turf when it reaches 3-inches in height, to not less than 2-inches. During the maintenance period do not allow the turf to exceed 3-1/4 inches in height. Collect and remove all grass clippings from the site as approved by the Engineer.
- j. Acceptance of turf areas will not be made until turf has received the second mowing and all bare spots have been re-sodded. Contractor shall be responsible for the maintenance of the turf areas until acceptance. Maintenance period may be extended by the Engineer as required.

6. Pruning:

- a. Prune minimum necessary to remove injured twigs, branches, dead wood, sprouts and suckers.
- b. Prune plants according to standard horticultural practices, by qualified personnel.
- c. No topping of any trees will be permitted. Trees that have been topped will be replaced at the contractor's expense.

7. Clean-up:

- a. During the course of the work, daily remove surplus materials from the site and leave premises in a neat and clean condition.

- b. Prior to acceptance of the project for maintenance, clean up and remove all remaining debris and surplus materials upon completion of work, leaving the premises neat and clean.
- c. Remove all tags, labels, nursery stakes and ties from all plant material only after the approval of the Engineer.

PLANTING SPECIFICATIONS: MAINTENANCE

1. Maintain all areas included in the contract on a weekly basis during the progress of the work, the 90 day maintenance period, and until the final acceptance of the work is received in writing. Maintenance is to include trash and weed removal on a weekly basis and a raking of the granite areas every other week.
2. After all the work indicated on the drawings or herein specified has been completed and inspected and approved by the Engineer on a 30 calendar day schedule; maintain all areas within the project boundary for a period of 90 calendar days.
3. Tree and Shrub Care:
 - a. Watering: Maintain a large enough water basin around plants so that enough water can be applied to establish moisture through the major root zone. When hand watering, use a wand to break the water force.
 - b. Tree Pruning:
 - i. Prune trees to select and develop permanent scaffold branches that are smaller in diameter to the trunk or branch of which they are attached, which have vertical spacing of from 18 to 48 inches and radial orientation so as not to overlay one another; to eliminate narrow V-shaped branch forks that lack thinning out crowns; to maintain growth within space balance crown with roots.
 - ii. Under no circumstances will stripping of lower branches or "raising up" of young trees be permitted. Retain lower branches in a "tipped back" or pinched condition with as much foliage as possible to promote trunk growth (tapered trunk). Lower branches may be removed only after the tree is able to stand erect without staking or other support.
 - iii. Use reduction cuts to thin out and shape evergreen trees when necessary to prevent wind and storm damage. Perform primary pruning to deciduous trees during the dormant season. Prune

damaged trees or those that constitute health or safety hazards at any time of the year as directed by the Engineer.

- c. Shrub Pruning:
 - i. The objectives of shrub pruning are the same as for trees. Do not clip shrubs into balled or boxed forms unless such is required by the design and designated on the planting plans.
 - ii. Make all pruning cuts of lateral branches or buds, as directed by the Engineer.
 - iii. Topping is not allowed.
- d. Staking: Remove stakes as soon as they are no longer needed. Remove stake completely and do not cut off at ground level. Inspect stakes to prevent girdling of trunks or branches, and to prevent rubbing that causes bark wounds. The contracting crew at the time of maintenance shall remove the stakes and cut the stakes so they are not protruding into the canopy.
- e. Weed control:
 - i. Keep basins and areas between plants free of weeds. Apply pre-emergent herbicides as recommended by a City licensed pest control advisor to all non-seeded landscape areas only. Apply twice prior, to granite and at the end of the 90 day maintenance period. The Contractor shall follow all applicable regulations pertaining to weed control. Avoid frequent soil cultivation that destroys shallow roots or disturbs pre-emergent herbicide application.
 - ii. Eradicate all noxious weeds from site (i.e. nutgrass, Bermuda grass, kikuyu grass, crab grass etc.).
- f. Insect and disease control: Maintain control with approved materials.
- g. Fertilization: Make three applications of commercial fertilizer at the rate of 5-6 lbs. per 1,000 square feet at the following periods: (Maintenance progress inspections are required for verification of fertilizer applications).
 - i. 30 calendar days after the maintenance period has begun.
 - ii. 60 calendar days after the maintenance period has begun.
 - iii. Just prior to the end of the 90 calendar day maintenance period.

Note: Application should be per manufacturer's recommendation per site and Engineer's approval.

- h. Replacement of plants: Remove dead and dying plants and replace with plants of equal size and variety of original planting plan at no additional cost to the City and as approved by the Engineer.
 - i. Groundcover Care: Apply a pre-emergent herbicide having a life no less than six (6) months to all ground cover and shrub areas. Herbicide shall be registered for use on the species of plant material specified in planting plans and applied by a licensed pest control applicator.
4. Turf care: (Depends on variety of turf)
- a. Mowing and Edging: Mow all turf areas to a minimum height of 3/4 inch and a maximum of 2-1/2 inch. Mowing height shall be determined by the Engineer. Mow at least once every seven (7) days during spring and fall seasons and as needed during other seasons.
 - b. Trim edges at least twice monthly or as needed with a power edger for a neat appearance. Vacuum or blow clippings off walks.
 - c. Watering: Water turf areas at such frequency as weather conditions require, replenishing soil moisture below root zone. Irrigation shall be scheduled between 10 p.m. and 6 a.m. following turf establishment.
5. General Maintenance:
- a. Remove trash and weed% weekly.
 - b. Edge ground cover to keep in bounds and trim top growth as necessary to achieve an overall even appearance.
 - c. Exterminate vertebrate pests, gophers, moles etc.; and repair damage as required.
 - d. Test irrigation system weekly and submit reports to Engineer.
 - e. The site temporary fence shall be maintained to ensure security to the site.
 - f. Rake all granite areas every other week.
 - g. Provide schedule of maintenance visits and procedures to the City of Tempe representative.

PLANTING SPECIFICATIONS: GUARANTEE

1. All trees (5 gallon and larger) shall be guaranteed for a period of one year. All shrubs and plant materials shall be guaranteed for a period of 90 calendar days. All guarantee periods commence from the time of final acceptance by the Engineer at the completion of the 90 calendar day maintenance period.
2. Replace, as soon as weather permits or as directed by the Engineer, all dead plants and all plants not in vigorous condition as noted during the inspections and maintenance period.
3. Plants used for replacements shall be the same kind and size as originally planted. Replacement plants shall be approved by the Engineer and shall be furnished, planted, fertilized as specified the same as the original plant materials. Replacement plants shall be maintained and guaranteed the same as the original plant materials from the date of replacement.

END OF SECTION

HYDROSEEDING SECTION

HYDROSEEDING SPECIFICATIONS: PRODUCTS

1. Materials:
 - a. Equipment shall have a built in agitation system and operating capacity sufficient to agitate, suspend and homogeneously mix a slurry containing not less than 20 kilos (44 lbs.) of organic mulching amendment plus fertilizer, chemical additives and solids for each 100 gallons of water.
 - b. Cellulose Fiber Mulch: Apply at a minimum rate of 1500 lbs./acre.
 - c. Fertilizers: Best 6-20-20 or Best 15-15-15 or approved equal applied at a rate appropriate for product.
 - d. Organic tackifier shall be applied at rate of 70lbs./acre.
 - e. Hydro-seed mix shall be applied at the lbs./1,1000 sq. ft. designated on the planting plans.

HYDROSEEDING SPECIFICATIONS: EXECUTION

1. Installation procedures:
 - a. Inspection of conditions: Examine related work including irrigation and grading of surface before proceeding with any work and notify the Engineer in writing on conditions which may prevent the proper execution of this work. Failure to report unsuitable conditions will require the contractor to rectify unacceptable work at no additional cost to the City.
 - b. Water all plant areas thoroughly to saturate upper layers of soil prior to the hydro-seeding operation.
 - c. Allow the planting area soil surface to dry out for one day only prior to the hydro-seeding application. Exercise care not to allow the soil surface to be overly saturated with water prior to the hydro-seeding installation. At the same time the soil surface should not become too dry during this period. There should be some residual moisture within the first 1/4 inch of the soil surface.
 - d. Prior to starting the hydro-seeding operation notify the Engineer forty-eight (48) hours in advance to be present at start of start of hydro-seeding.

2. Hydro-seeding Application:

- a. Apply the hydro-seeding in the form of a slurry consisting of organic soil amendments, commercial fertilizer, and any other chemicals that are called out. When hydraulically sprayed onto the soil, the mulch shall form a blotter-like material. Direct the spray operation so that this procedure will drill and mix the slurry components into the soil, the slurry spray will also penetrate the soil surface, thus ensuring maximum impregnation and coverage. The impregnation and mixing of the components will help in retaining moisture while stabilizing soil surface from superficial erosion.
- b. Do not let the hydro-seeding slurry components in the hydro-seeding machine for more than two (2) hours because of possible seed destruction. If slurry components are left for more than two hours in the machine, add 50% more of the originally specified seed mix to any slurry mixture which has not been applied within the two hours after mixing. Add 75% more of the original seed mix to any slurry mixture which has not been applied eight (8) hours after mixing. All mixtures more than eight (8) hours old must be disposed, off-site, at the contractor's expense.
- c. Spray the area with a uniform visible coat, using the dark color of the cellulose fiber as a visual guide. The slurry shall be applied in a downward drilling motion via a fan stream nozzle. Insure that all of the slurry components enter and mix with the soil. Insure the uniformity of the hydro-seed application. The hydraulic contractor shall be approved by the Engineer.
- d. Exercise special care to prevent any of the slurry from being sprayed onto any hardscape areas including concrete walks, fences, walls, buildings, etc. Remove all slurry sprayed onto these surfaces at the contractor's expense.
- e. Contractor shall save all seed and fertilizer tags and fiber mulch bags for the Engineer to verify compliance with the drawings and specifications.
- f. The Engineer shall be present during the hydro-seeding operation and has final determination if conditions are acceptable for hydro-seed application.

HYDROSEEDING SPECIFICATIONS: MAINTENANCE

1. Upon acceptance of hydro-seeding operations, maintain all hydro-seeding areas for a period of 90 calendar days as follows:
 - a. Germination stage irrigation: Approximately 25 hours after hydro-seeding the planting areas, initiate the watering sequence. Leave the water on long enough to moisten the soil thoroughly to the depth of the slurry mulch taking care not to super saturate or wash away the slurry and seed. Perform frequent, light irrigation until the seed has germinated. Repair all seed washings and erosion.
 - b. Establishment stage irrigation: After germination, reduce each watering. The specific watering program shall be approved by the Engineer.
2. Fertilization: Fertilize all hydro-seed areas per manufacturer's recommendations with an approved commercial fertilizer, 30 calendar days from the start of the maintenance period and continuing once every 60 calendar days until the completion of the 90 calendar day maintenance period.
3. Weeding: All concentrated developments of weed growth appearing in the seed mix planting areas during the maintenance period shall be removed at two (2) week intervals. The contractor may elect to remove such concentrations of weeds manually or by a City approved herbicide program.
4. Minimum Coverage and Acceptance:
 - a. Minimum coverage: Final acceptance may be given at the end of the 90 calendar day maintenance period if an acceptable germination of turf and adequate plant establishment has been obtained, as determined by the Engineer.
 - b. Final approval and acceptance will be given in writing by the Engineer following a formal acceptance inspection. The Engineer reserves the option to extend the maintenance period to achieve complete germination of all turf or other plant materials with a uniform height, color and density throughout all hydro-seeded areas.

END OF SECTION

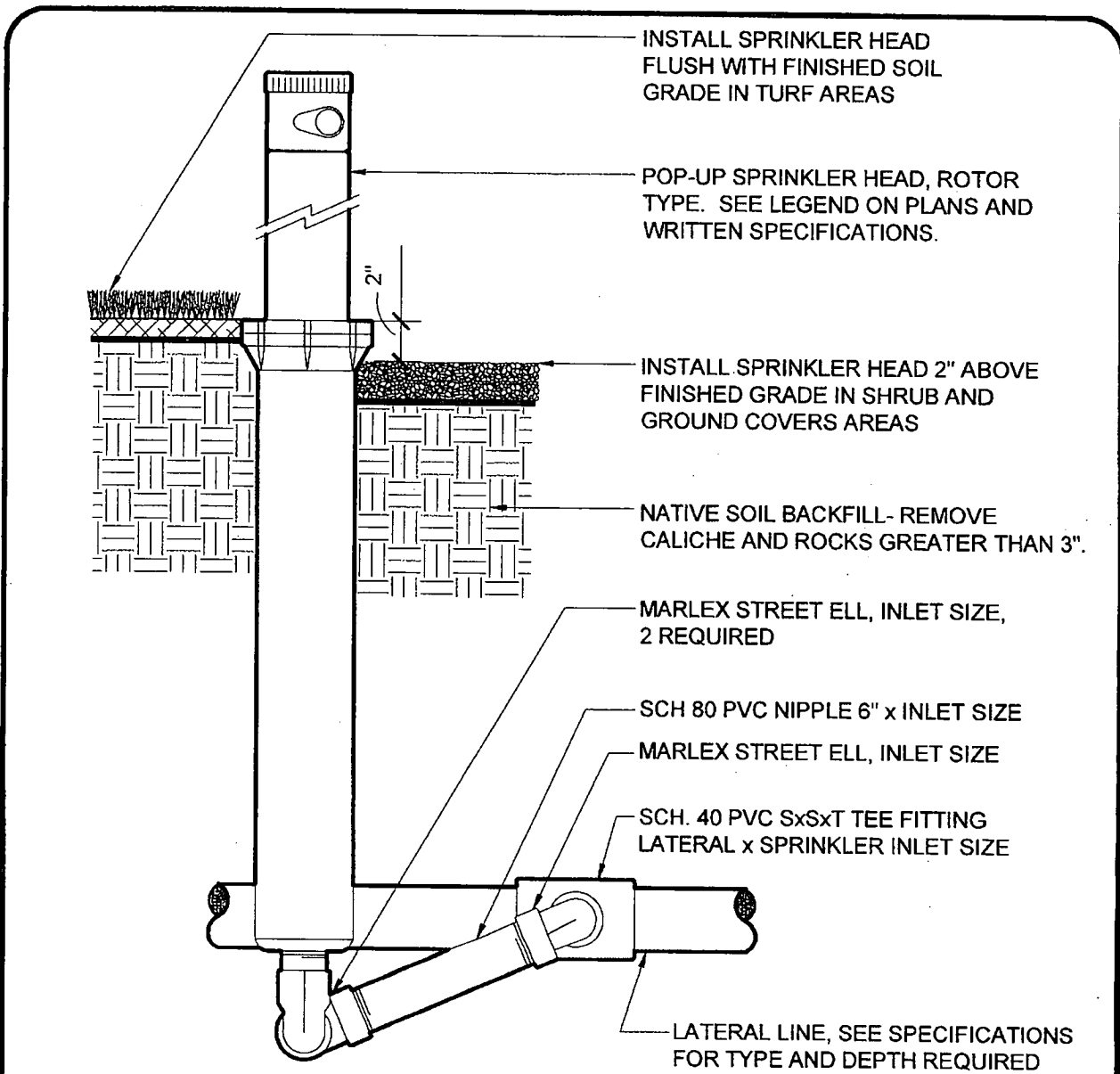

NOTES:

1. INSTALL SPRINKLER HEADS 6" FROM PAVING EDGE IN GROUND COVER AREAS.
2. INSTALL SPRINKLER HEADS 4" FROM PAVING EDGE IN TURF AREAS.
3. INSTALL SPRINKLER HEADS PLUMB. ADJUST NOZZLE STREAM TO COVER LANDSCAPE AREA WITHOUT OVERSPRAY ONTO PAVING, FENCES, WALLS OR BUILDINGS.
4. USE TEFLON TAPE ON ALL THREADED FITTINGS UNLESS PROHIBITED BY MANUFACTURER.

	CITY OF TEMPE / PUBLIC WORKS DEPARTMENT	NOT TO SCALE
	POP-UP SPRINKLER ROTOR TYPE (12")	
	APPROVED: <i>Andya</i> <small>DEPUTY PUBLIC WORKS DIRECTOR/CITY ENGINEER</small>	7/21/11 <small>DATE</small>

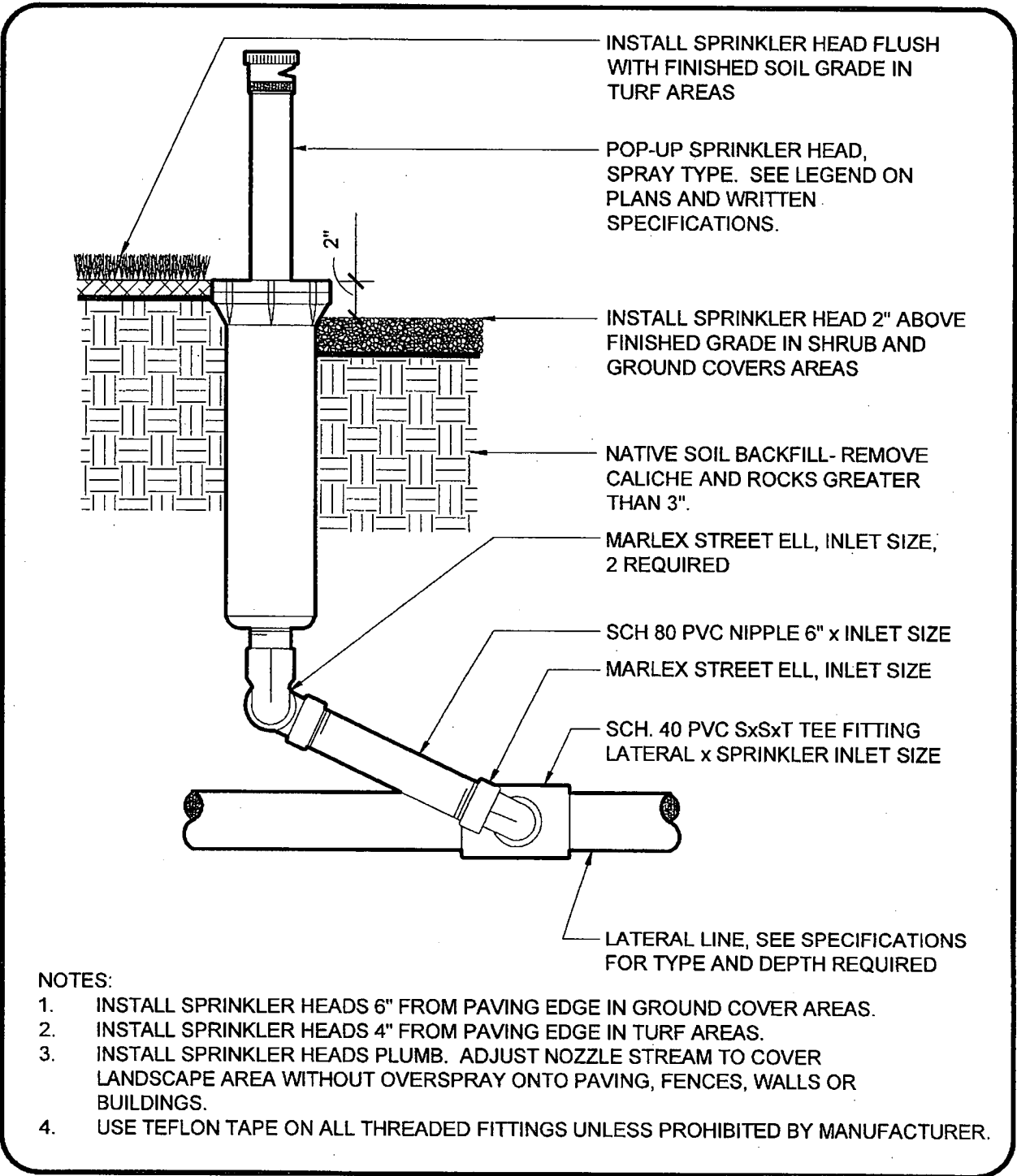

NOTES:

1. INSTALL SPRINKLER HEADS 6" FROM PAVING EDGE IN GROUND COVER AREAS.
2. INSTALL SPRINKLER HEADS 4" FROM PAVING EDGE IN TURF AREAS.
3. INSTALL SPRINKLER HEADS PLUMB. ADJUST NOZZLE STREAM TO COVER LANDSCAPE AREA WITHOUT OVERSPRAY ONTO PAVING, FENCES, WALLS OR BUILDINGS.
4. USE TEFLON TAPE ON ALL THREADED FITTINGS UNLESS PROHIBITED BY MANUFACTURER.

	CITY OF TEMPE / PUBLIC WORKS DEPARTMENT	NOT TO SCALE
	POP-UP SPRINKLER SPRAY TYPE (4" & 6")	
	APPROVED: <u>Andy</u> <small>DEPUTY PUBLIC WORKS DIRECTOR / CITY ENGINEER</small>	<u>7/21/11</u> <small>DATE</small>

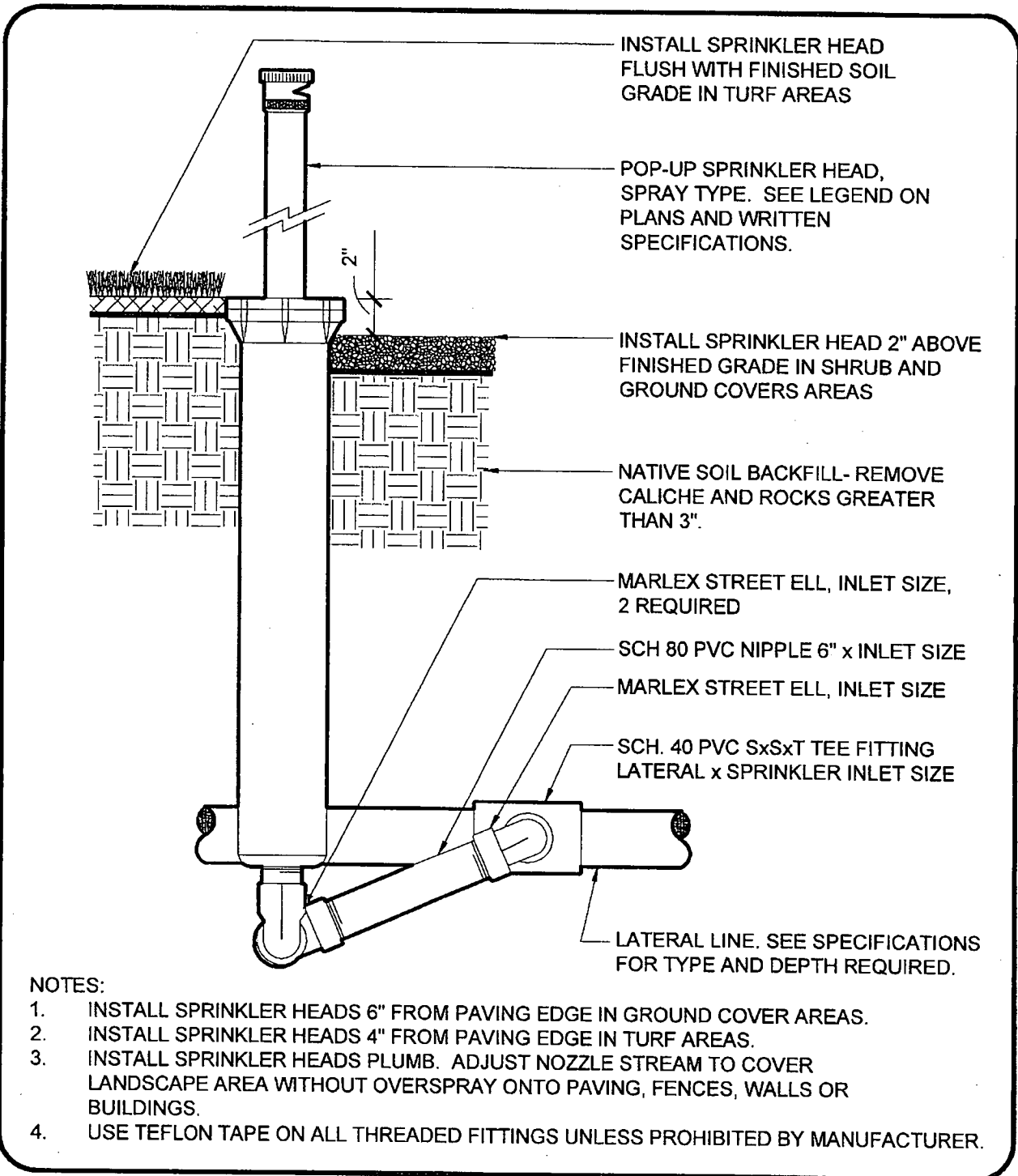

	CITY OF TEMPE / PUBLIC WORKS DEPARTMENT	NOT TO SCALE
	POP-UP SPRINKLER SPRAY TYPE (12")	
	APPROVED: <u>Andy</u> <small>DEPUTY PUBLIC WORKS DIRECTOR/CITY ENGINEER</small>	<u>7/21/11</u> <small>DATE</small>

NOTE:
FOR USE IN FLOOD
IRRIGATED AREAS OR
TRANSITION AREAS

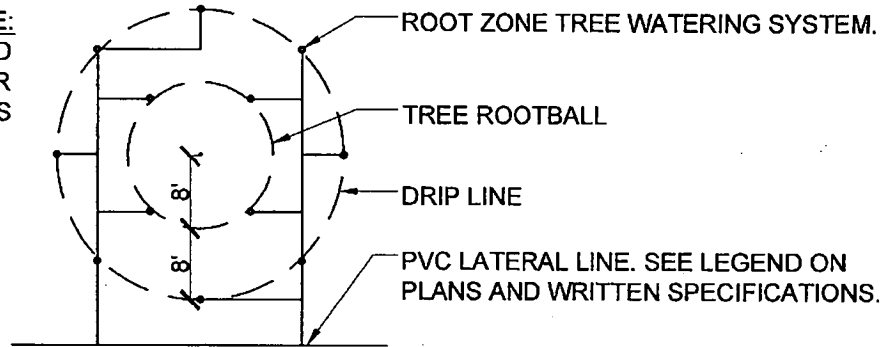

EXISTING MATURE TREE

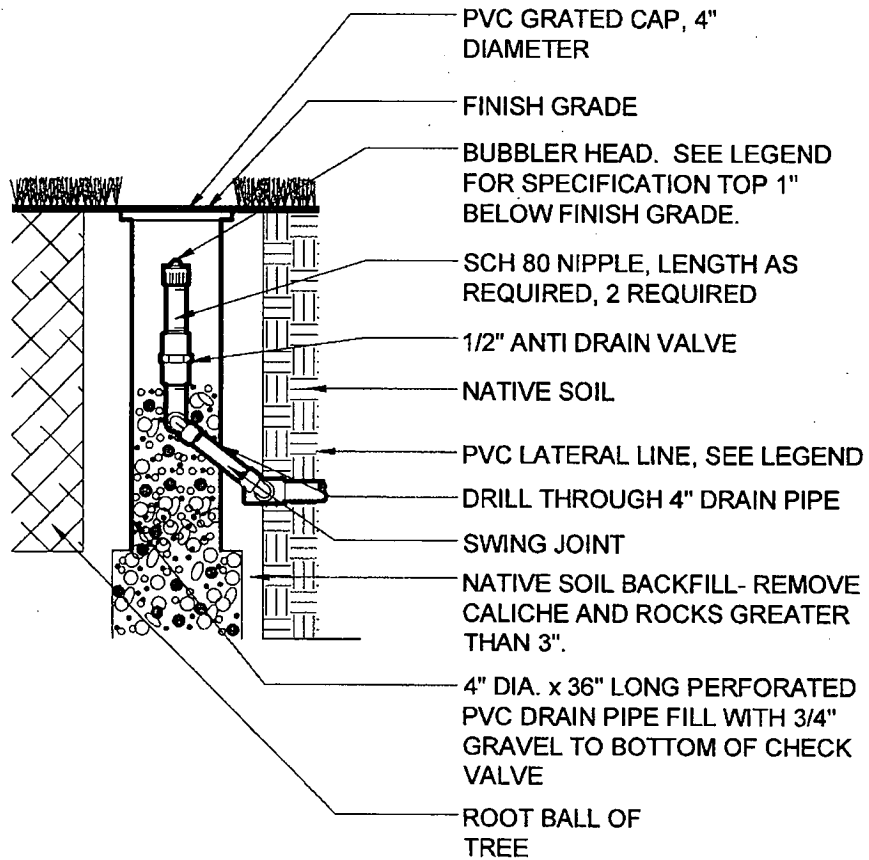

SECTION VIEW - N.T.S.



CITY OF TEMPE / PUBLIC WORKS DEPARTMENT

NOT TO SCALE

**ROOT ZONE WATERING
SYSTEM IN FLOOD IRRIGATION**

T-705

APPROVED: _____

Andy
DEPUTY PUBLIC WORKS DIRECTOR / CITY ENGINEER

7/21/11
DATE

REVISED JULY 2011

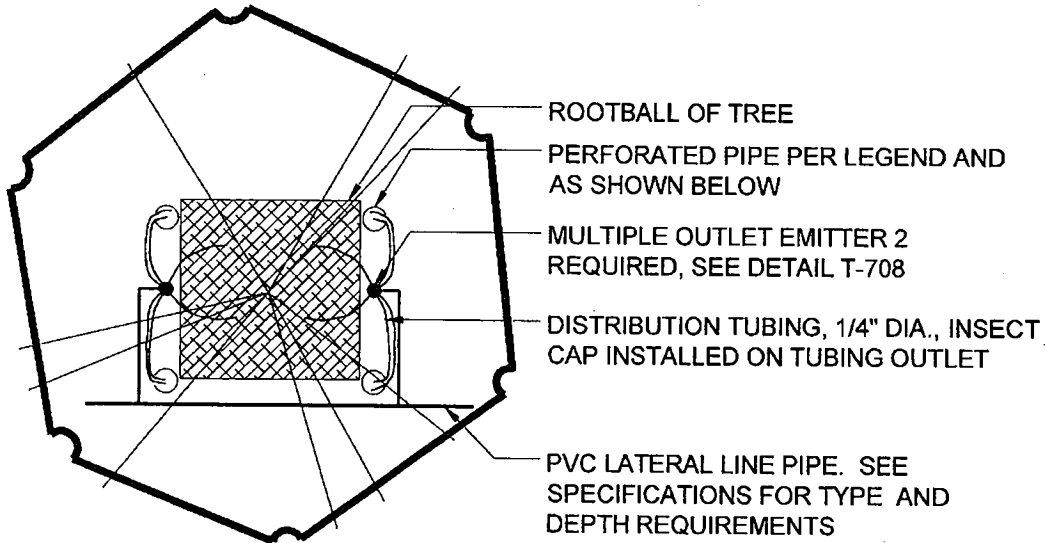

PLAN VIEW

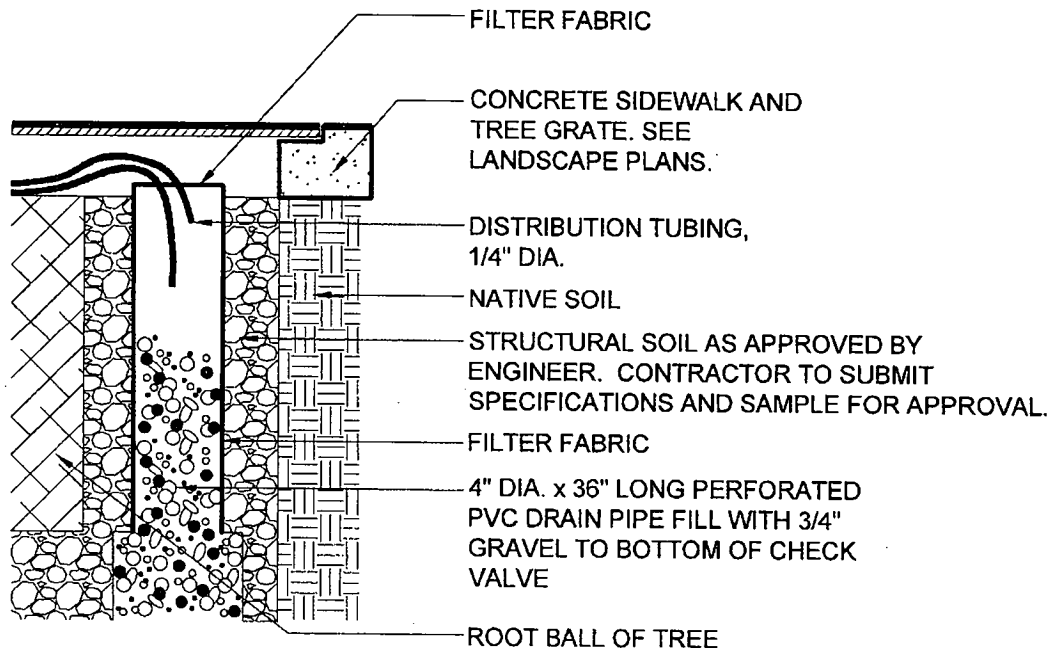

SECTION VIEW - N.T.S.



CITY OF TEMPE / PUBLIC WORKS DEPARTMENT

NOT TO SCALE

ROOT ZONE WATERING
SYSTEM IN TREE GRATE

T-706

APPROVED:

Andy
DEPUTY PUBLIC WORKS DIRECTOR / CITY ENGINEER

7/21/11
DATE

REVISED JULY 2011

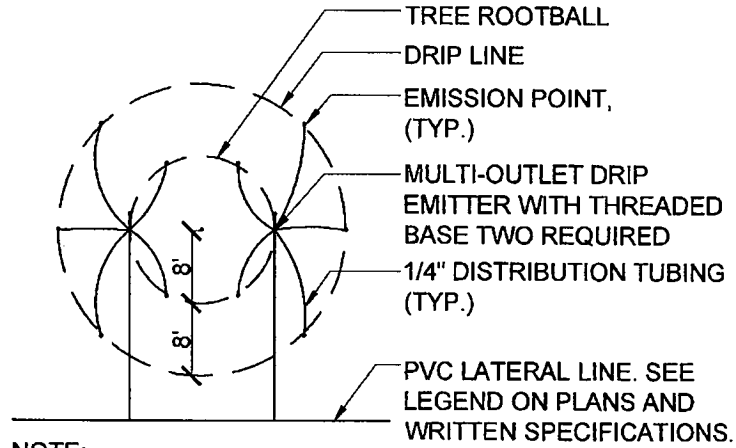

NOTE:
 FOR EXISTING TREES IN FLAT TURF AREAS

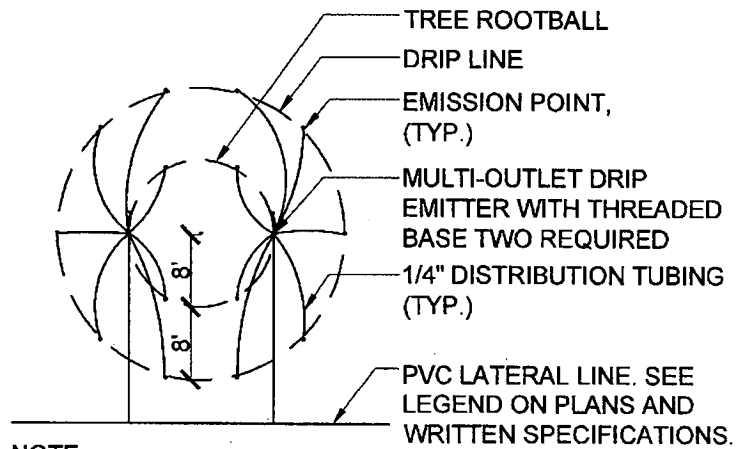

NOTE:
 FOR EXISTING TREES IN FLAT DECOMPOSED GRANITE AREAS



CITY OF TEMPE / PUBLIC WORKS DEPARTMENT

NOT TO SCALE

**ROOT ZONE WATERING
 SYSTEM FOR EXISTING TREES**

T-707

APPROVED:

Andy

DEPUTY PUBLIC WORKS DIRECTOR / CITY ENGINEER

7/21/11

DATE

REVISED JULY 2011

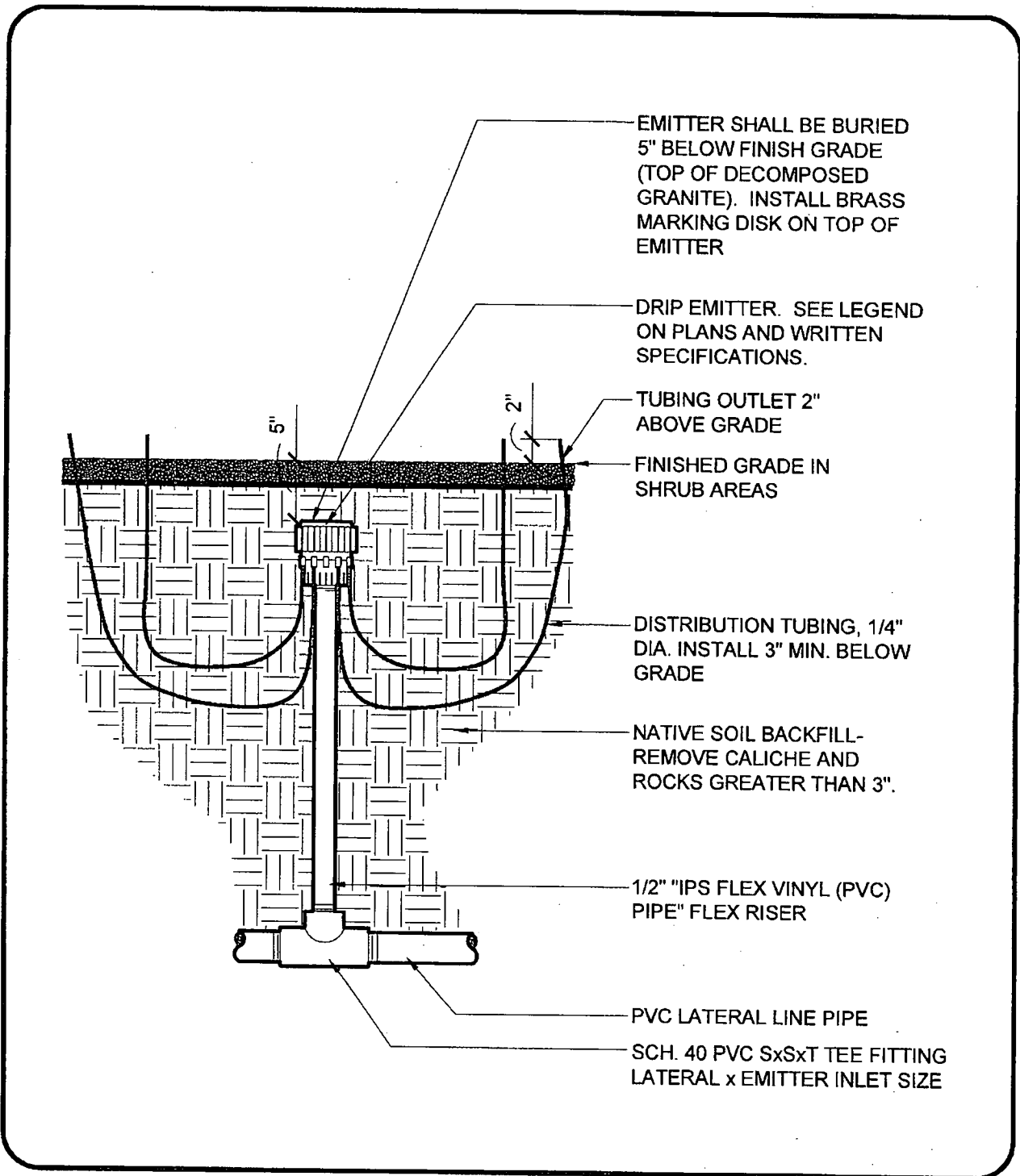

	CITY OF TEMPE / PUBLIC WORKS DEPARTMENT	NOT TO SCALE
	MULTI-OUTLET EMITTER INSTALLED BELOW GRADE	
	APPROVED: <u>Andy</u> <small>DEPUTY PUBLIC WORKS DIRECTOR / CITY ENGINEER</small>	<u>7/21/11</u> <small>DATE</small>

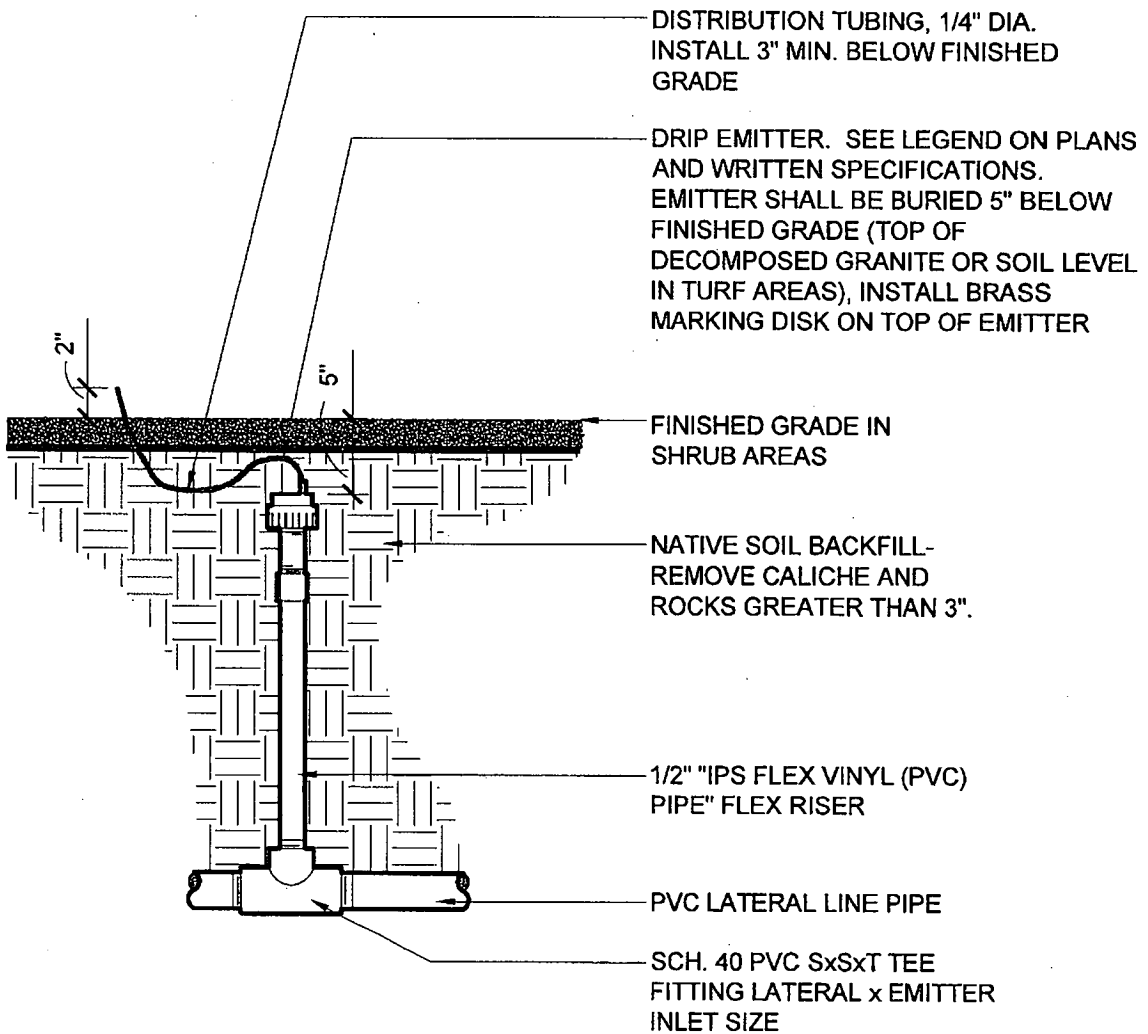

CITY OF TEMPE / PUBLIC WORKS DEPARTMENT

NOT TO SCALE

**SINGLE-OUTLET EMITTER
INSTALLED BELOW GRADE**

T-709

APPROVED: _____

DEPUTY PUBLIC WORKS DIRECTOR / CITY ENGINEER

7/21/11
DATE

REVISED JULY 2011

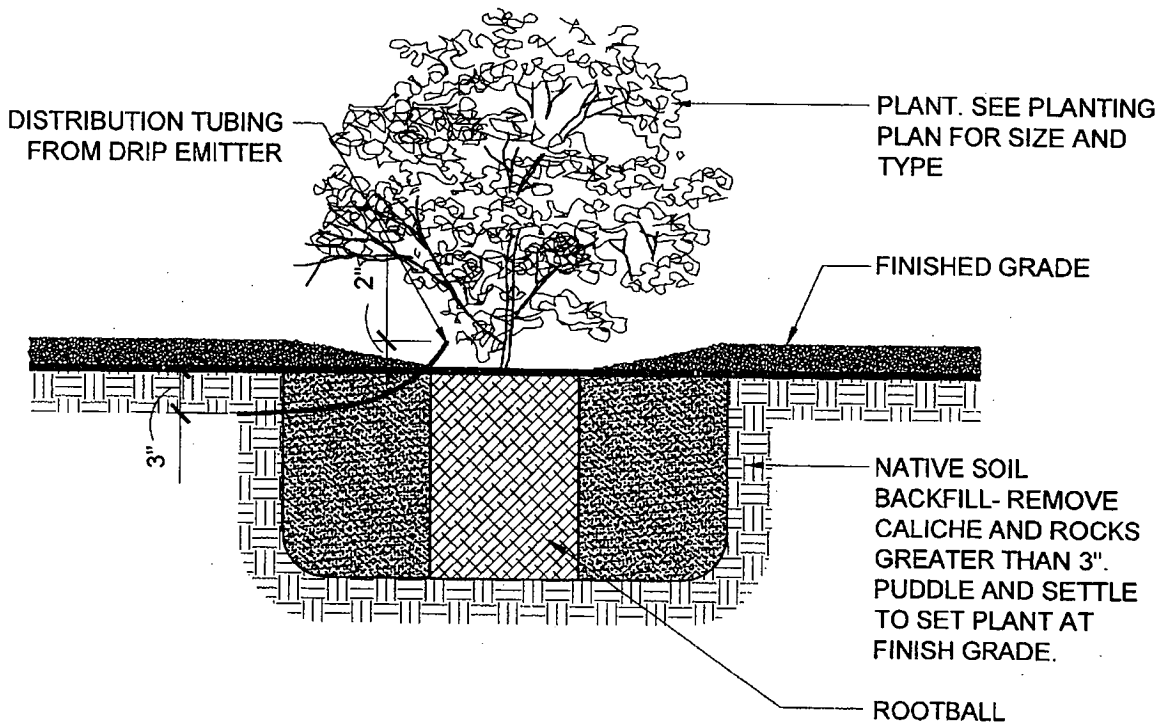

NOTES:

1. DISTRIBUTION TUBING SHALL BE INSTALLED A MIN. OF 3" BELOW FINISHED GRADE.
2. THE NUMBER AND VOLUME OF EMITTERS SHALL BE AS INDICATED ON THE IRRIGATION DRAWINGS. FOR PLANTS WITH MULTIPLE EMITTERS, SPACE OUTLETS EVENLY AROUND THE ROOT BALL.
3. THE DRIP TUBING OUTLET SHALL BE POSITIONED OVER THE PLANT ROOTBALL.



CITY OF TEMPE / PUBLIC WORKS DEPARTMENT

NOT TO SCALE

DRIP EMITTER
TUBING OUTLET

T-710

APPROVED:

DEPUTY PUBLIC WORKS DIRECTOR / CITY ENGINEER

Andy

7/21/11

DATE

REVISED JULY 2011

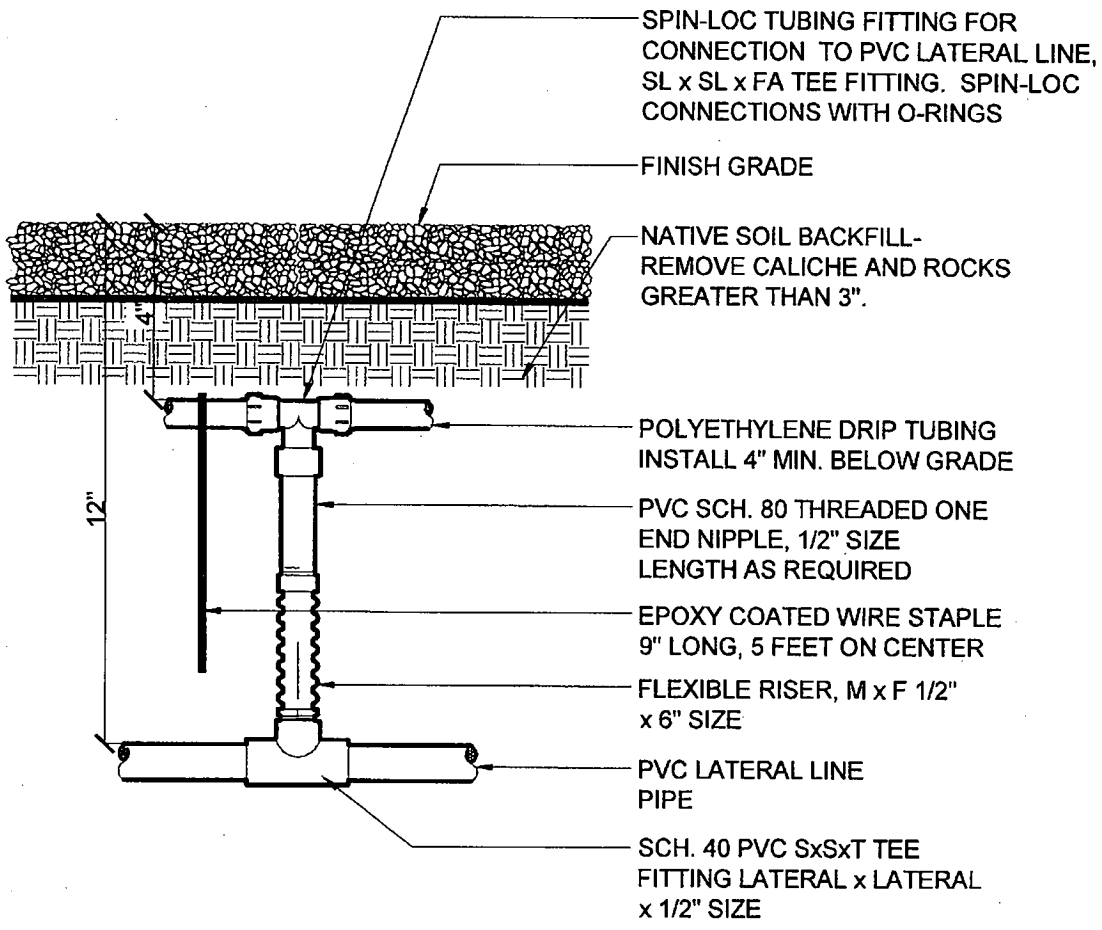

NOTES:
 INSTALL TUBING AT CONSISTENT DEPTH BELOW GRADE. SECURE TUBING WITH STAPLES 5 FEET ON CENTER TO PREVENT SURFACING OF TUBING DURING BACKFILL. DRIPPER LINE TUBING SHALL BE INSTALLED IN PARALLEL ROWS. BLANK TUBING FOR PUNCHED IN EMITTERS SHALL BE INSTALLED AS INDICATED ON THE DRAWINGS.



CITY OF TEMPE / PUBLIC WORKS DEPARTMENT

NOT TO SCALE

**FLEXIBLE DRIP TUBING
 INSTALLED BELOW GRADE**

T-711

APPROVED: Andy
DEPUTY PUBLIC WORKS DIRECTOR/ CITY ENGINEER

7/21/11
DATE

REVISED JULY 2011

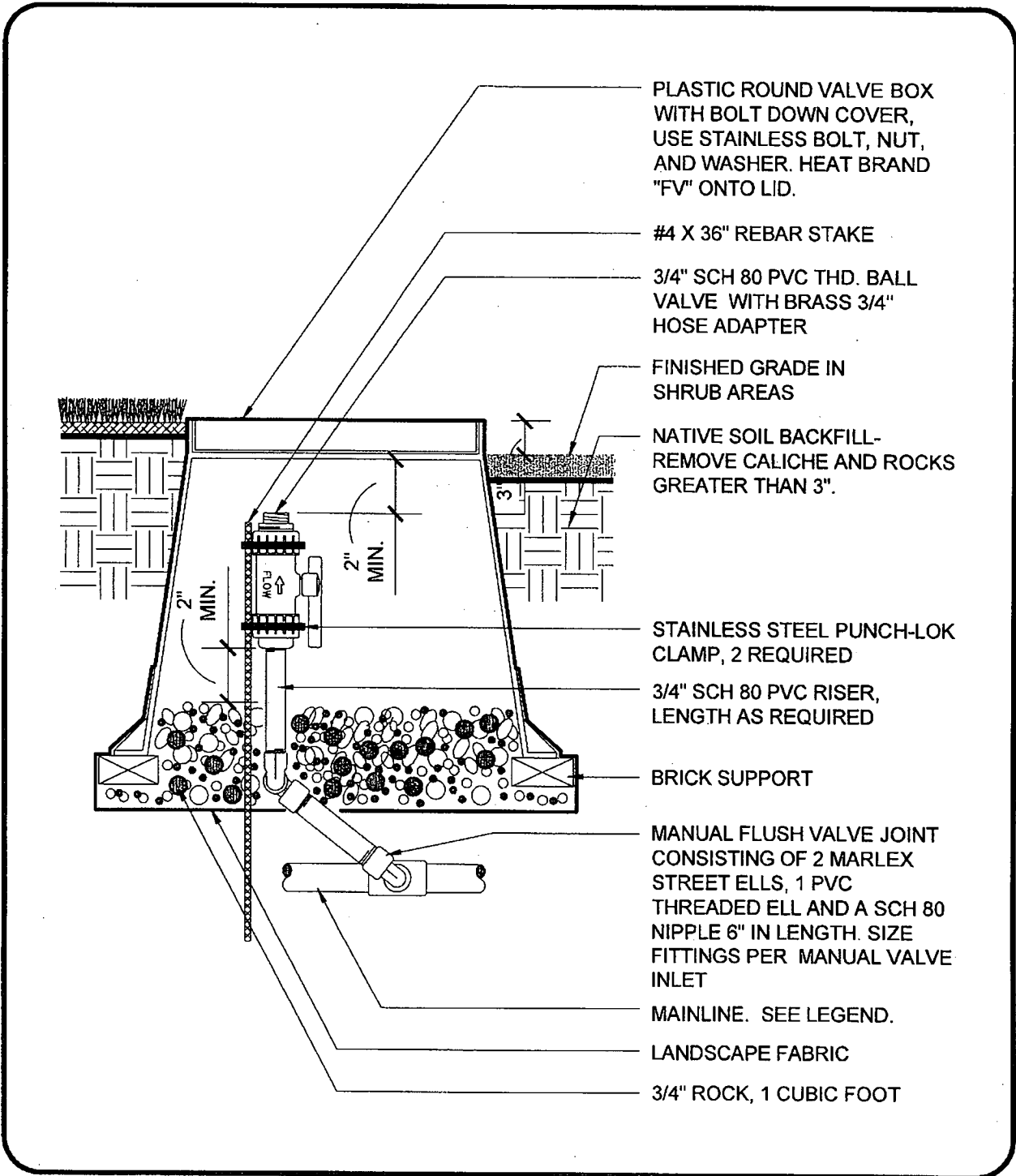

	CITY OF TEMPE / PUBLIC WORKS DEPARTMENT	NOT TO SCALE
	<h2>MANUAL FLUSH VALVE INSTALLED IN BOX</h2>	
	APPROVED: <u>Andy</u> <small>DEPUTY PUBLIC WORKS DIRECTOR/CITY ENGINEER</small>	<u>7/21/11</u> <small>DATE</small>

REVISED JULY 2011

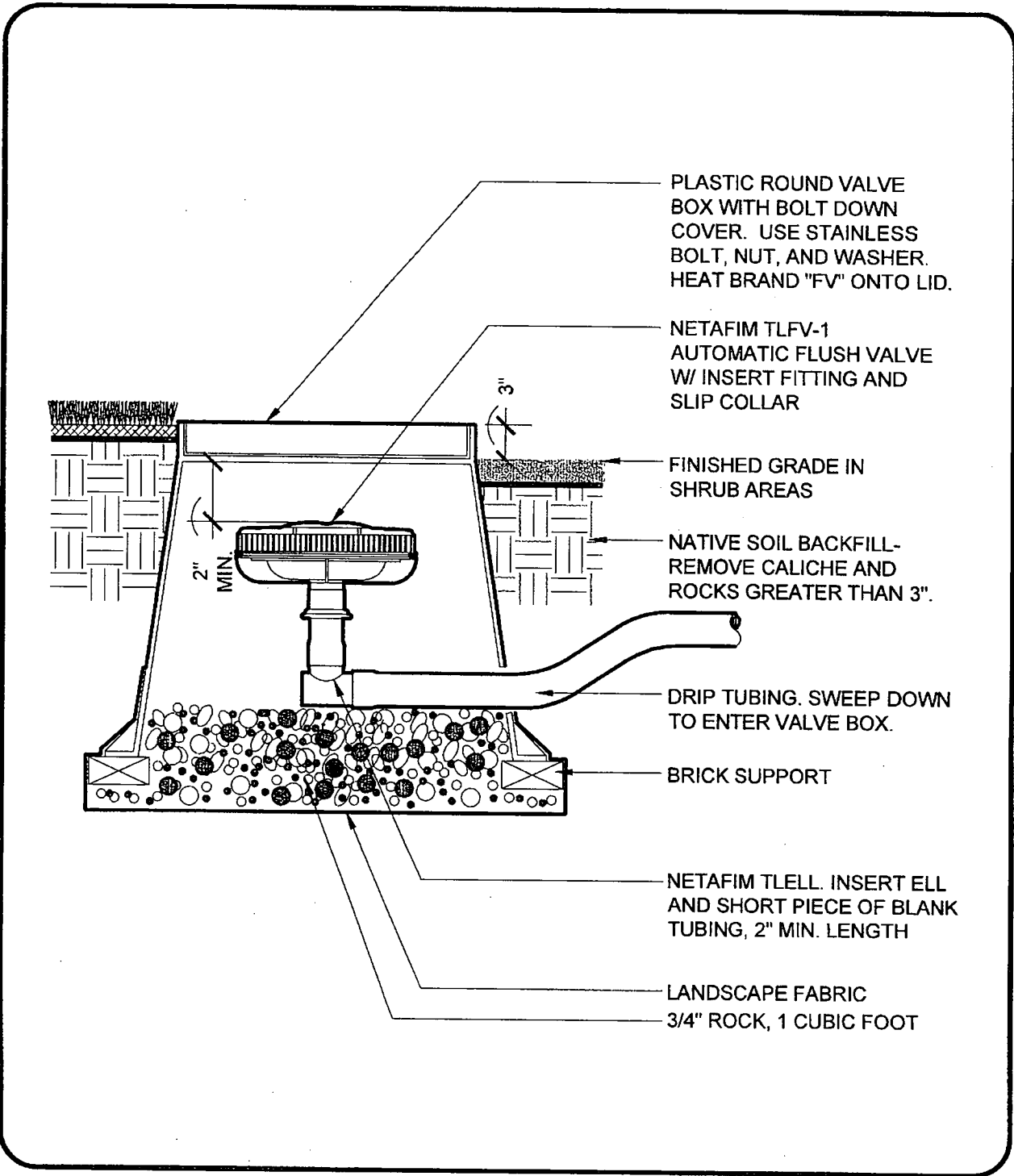

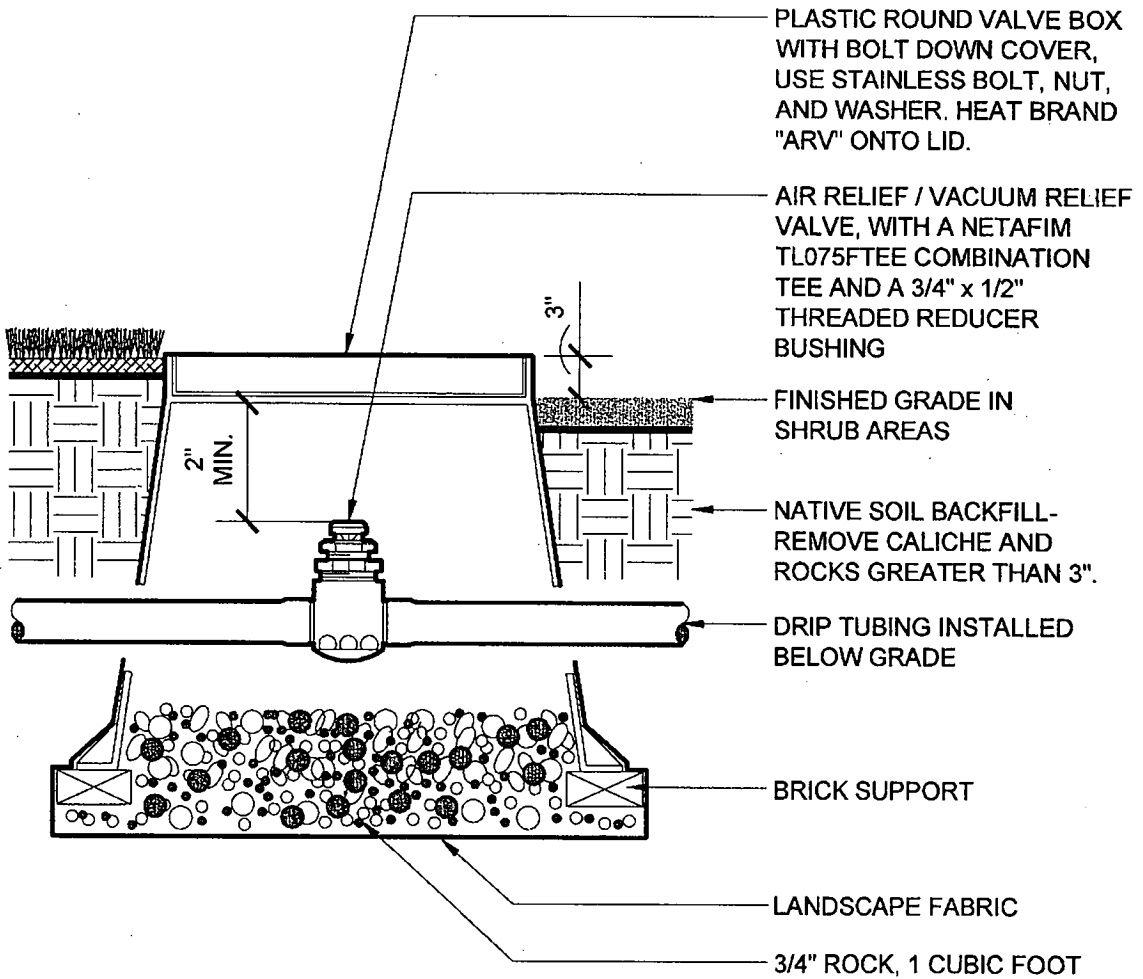

	CITY OF TEMPE / PUBLIC WORKS DEPARTMENT	NOT TO SCALE
	AUTOMATIC FLUSH VALVE INSTALLED IN BOX	
	APPROVED: <i>Andy</i> <small>DEPUTY PUBLIC WORKS DIRECTOR/ CITY ENGINEER</small>	7/21/11 <small>DATE</small>

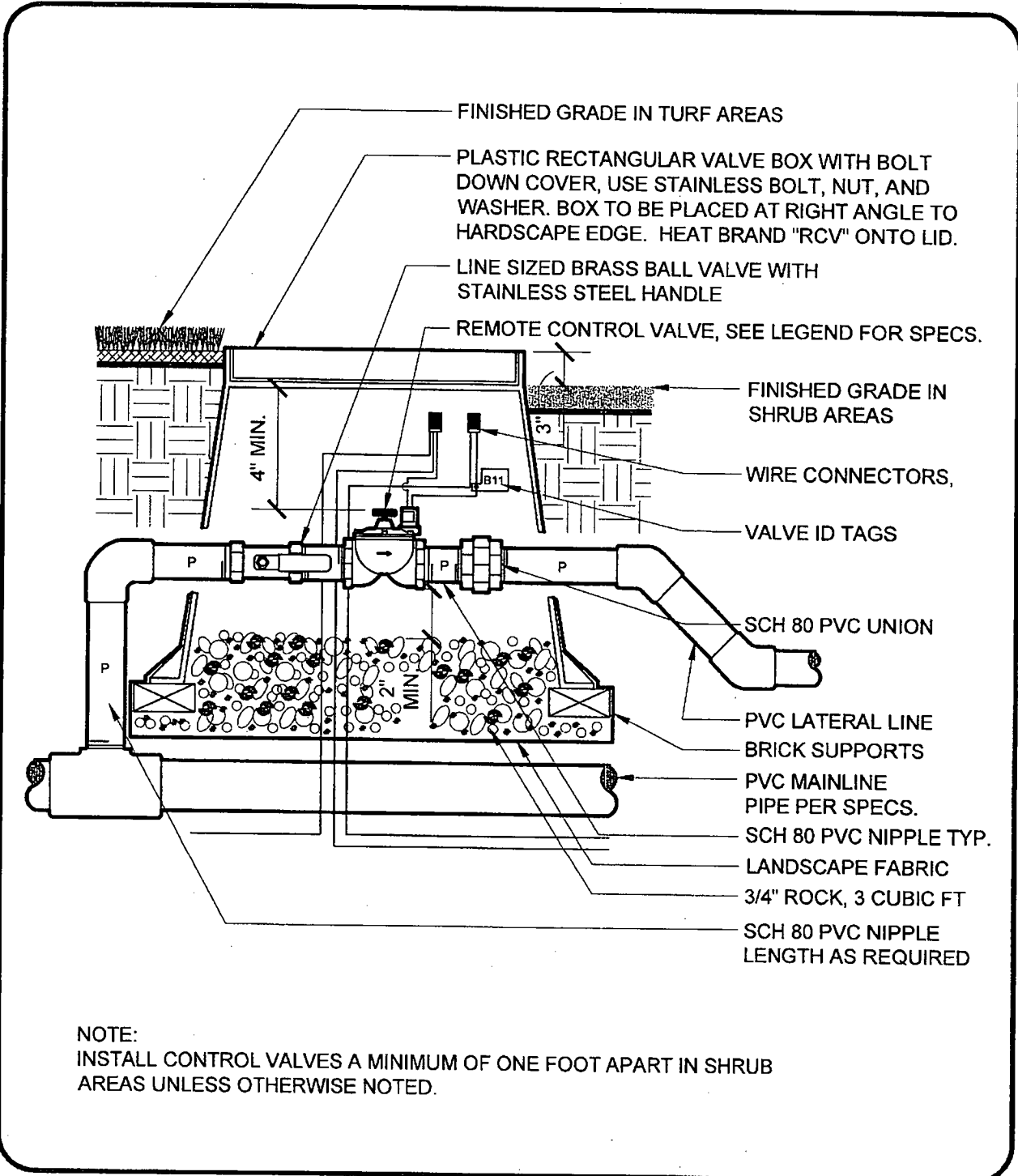

NOTES:
 INSTALL AIR/VACUUM RELIEF VALVE AT THE HIGHEST POINT OF THE DRIP TUBING SYSTEM. FLUSH ALL LINES PRIOR TO INSTALLATION OF VALVE.

	CITY OF TEMPE / PUBLIC WORKS DEPARTMENT	NOT TO SCALE
	AIR / VACUUM RELIEF VALVE INSTALLED IN BOX	
	APPROVED: <u>Andy</u> <small>DEPUTY PUBLIC WORKS DIRECTOR / CITY ENGINEER</small>	<u>7/21/11</u> <small>DATE</small>



	CITY OF TEMPE / PUBLIC WORKS DEPARTMENT	NOT TO SCALE
	REMOTE CONTROL VALVE INSTALLED IN BOX	
	APPROVED:  <small>DEPUTY PUBLIC WORKS DIRECTOR / CITY ENGINEER</small>	7/21/11 <small>DATE</small>

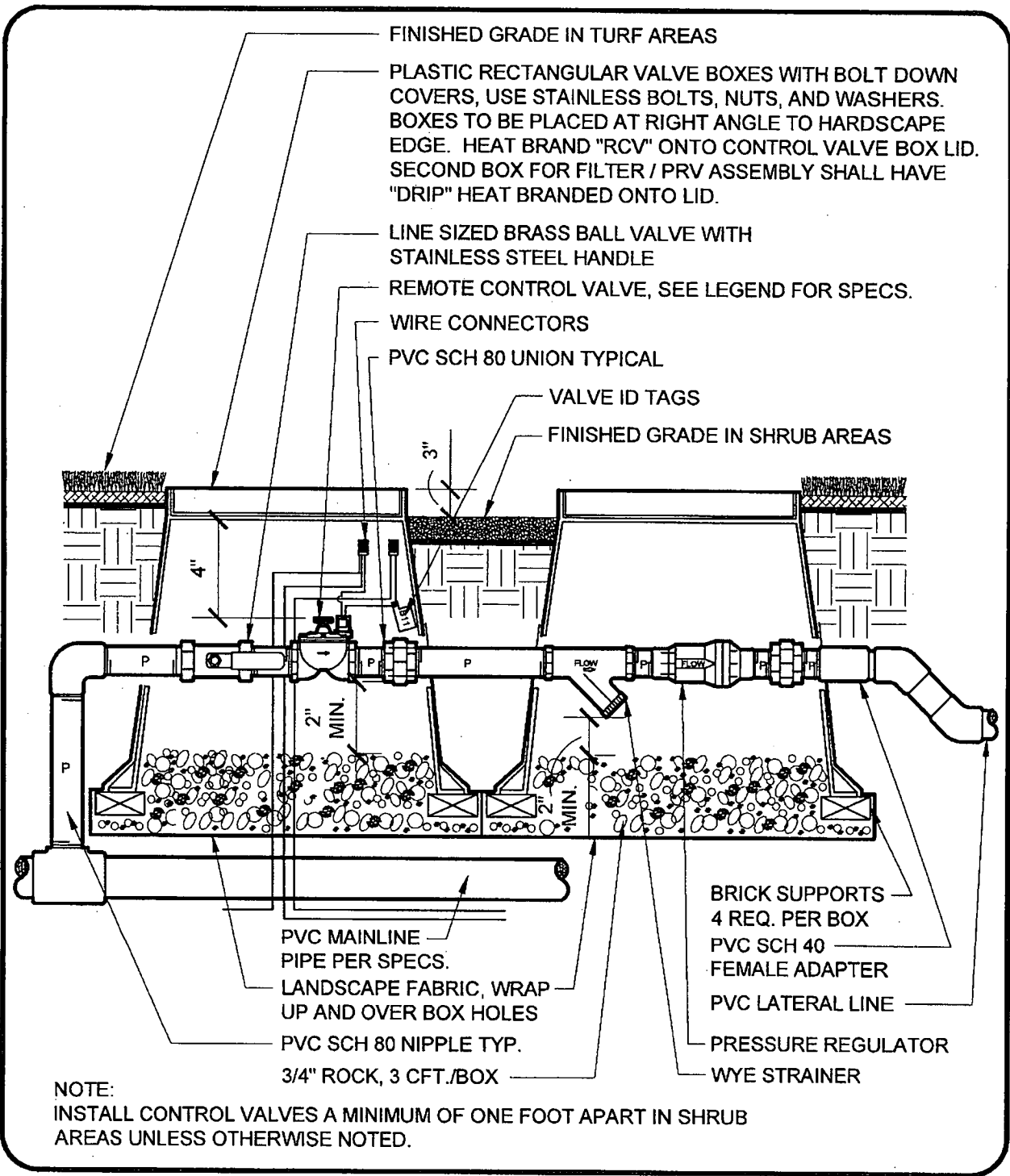

FINISHED GRADE IN TURF AREAS

PLASTIC RECTANGULAR VALVE BOXES WITH BOLT DOWN COVERS, USE STAINLESS BOLTS, NUTS, AND WASHERS. BOXES TO BE PLACED AT RIGHT ANGLE TO HARDSCAPE EDGE. HEAT BRAND "RCV" ONTO CONTROL VALVE BOX LID. SECOND BOX FOR FILTER / PRV ASSEMBLY SHALL HAVE "DRIP" HEAT BRANDED ONTO LID.

LINE SIZED BRASS BALL VALVE WITH STAINLESS STEEL HANDLE

REMOTE CONTROL VALVE, SEE LEGEND FOR SPECS.

WIRE CONNECTORS

PVC SCH 80 UNION TYPICAL

VALVE ID TAGS

FINISHED GRADE IN SHRUB AREAS

BRICK SUPPORTS — 4 REQ. PER BOX

PVC SCH 40 — FEMALE ADAPTER

PVC LATERAL LINE

PRESSURE REGULATOR

WYE STRAINER

PVC MAINLINE PIPE PER SPECS.

LANDSCAPE FABRIC, WRAP UP AND OVER BOX HOLES

PVC SCH 80 NIPPLE TYP.

3/4" ROCK, 3 CFT./BOX

NOTE:
INSTALL CONTROL VALVES A MINIMUM OF ONE FOOT APART IN SHRUB AREAS UNLESS OTHERWISE NOTED.

	CITY OF TEMPE / PUBLIC WORKS DEPARTMENT	NOT TO SCALE
	<h2>DRIP REMOTE CONTROL VALVE & PRESSURE REDUCTION ASSEMBLY</h2>	
	APPROVED: <small>DEPUTY PUBLIC WORKS DIRECTOR / CITY ENGINEER</small>	DATE: 7/21/11

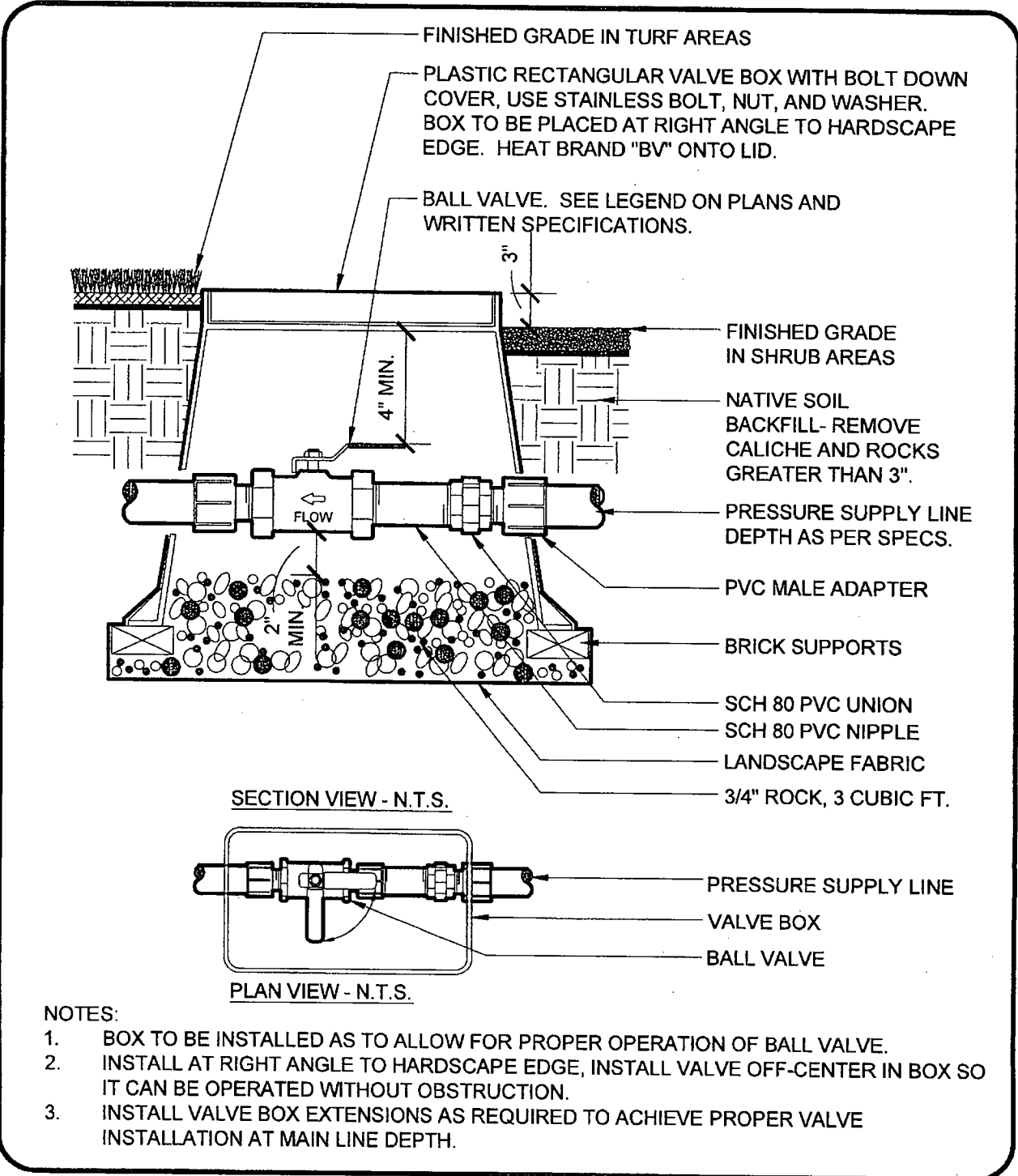

REVISED JULY 2011

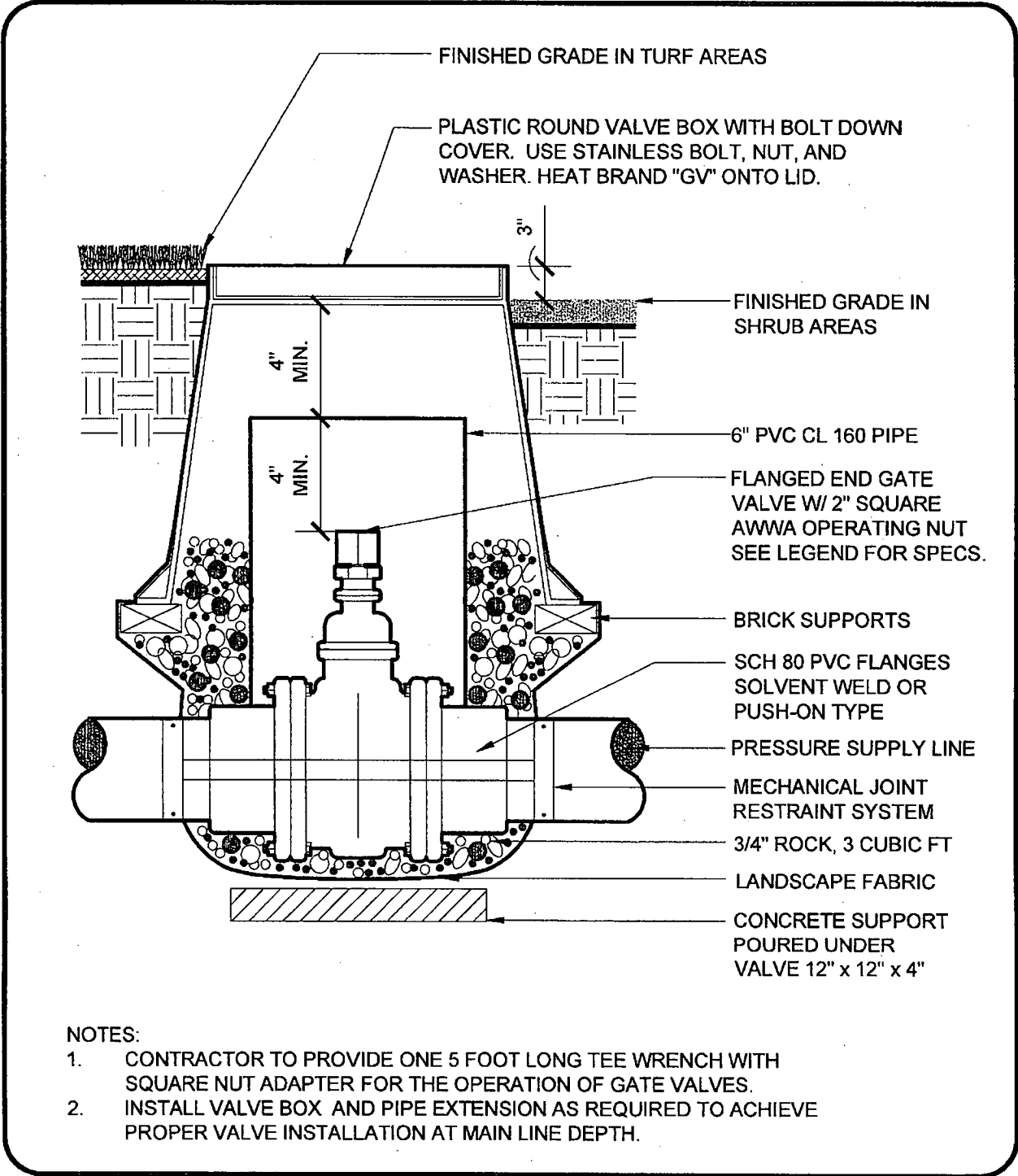

	CITY OF TEMPE / PUBLIC WORKS DEPARTMENT	NOT TO SCALE
	<h2>BALL VALVE INSTALLED IN BOX</h2>	
	APPROVED: <u>Andy</u> <small>DEPUTY PUBLIC WORKS DIRECTOR/CITY ENGINEER</small>	DATE: <u>7/21/11</u>

REVISED JULY 2011



	CITY OF TEMPE / PUBLIC WORKS DEPARTMENT	NOT TO SCALE
	GATE VALVE 2-1/2" AND LARGER INSTALLED IN BOX	
	APPROVED:  <small>DEPUTY PUBLIC WORKS DIRECTOR/ CITY ENGINEER</small>	7/21/11 <small>DATE</small>

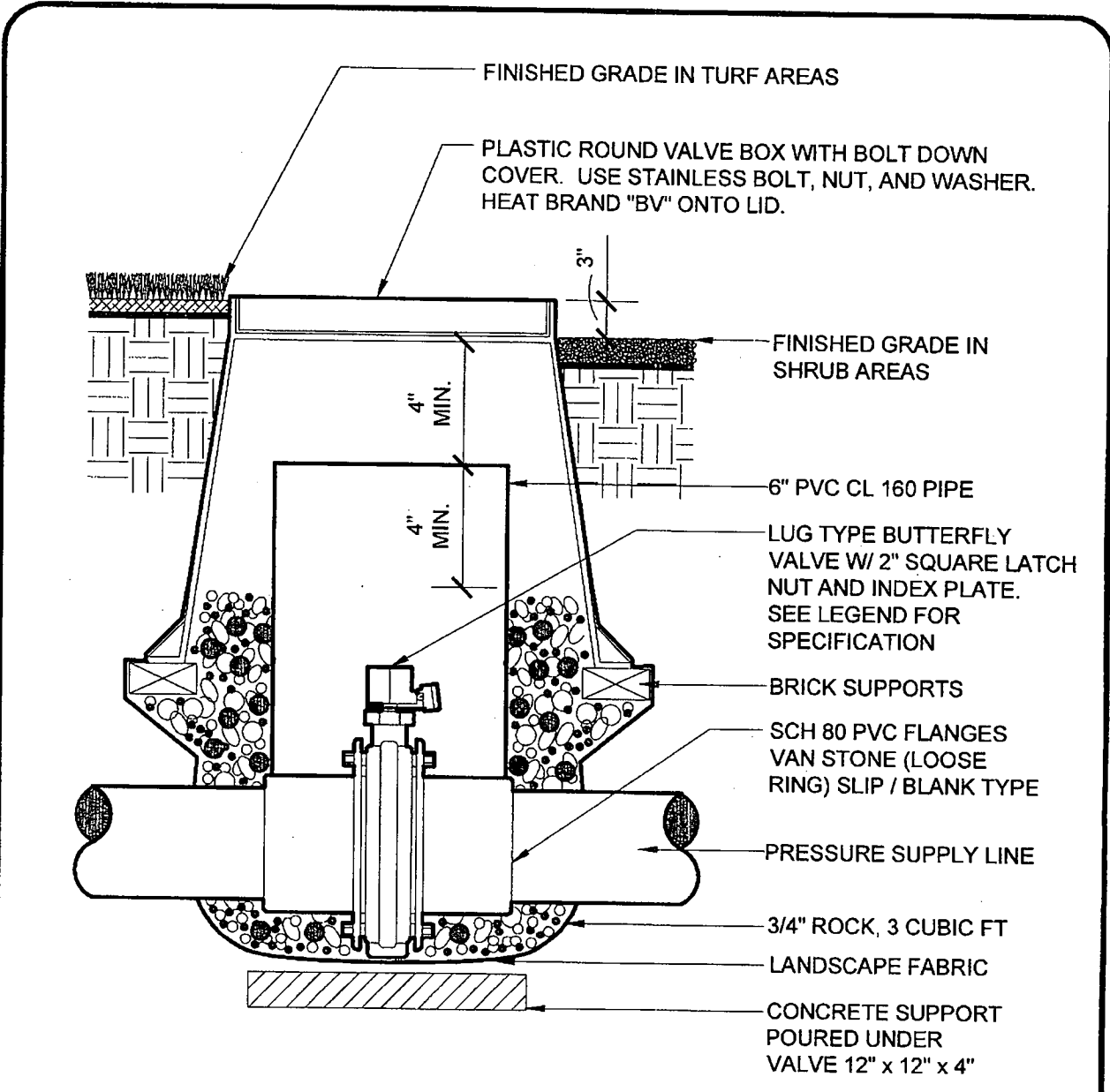

- NOTES:
1. CONTRACTOR TO PROVIDE ONE 5 FOOT LONG TEE WRENCH WITH SQUARE NUT ADAPTER FOR THE OPERATION OF BUTTERFLY VALVES.
 2. INSTALL VALVE BOX AND PIPE EXTENSION AS REQUIRED TO ACHIEVE PROPER VALVE INSTALLATION AT MAIN LINE DEPTH.

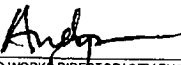
	CITY OF TEMPE / PUBLIC WORKS DEPARTMENT	NOT TO SCALE
	<h2>BUTTERFLY VALVE INSTALLED IN BOX</h2>	
	APPROVED:  <small>DEPUTY PUBLIC WORKS DIRECTOR/ CITY ENGINEER</small>	7/21/11 <small>DATE</small>
<small>REVISED JULY 2011</small>		

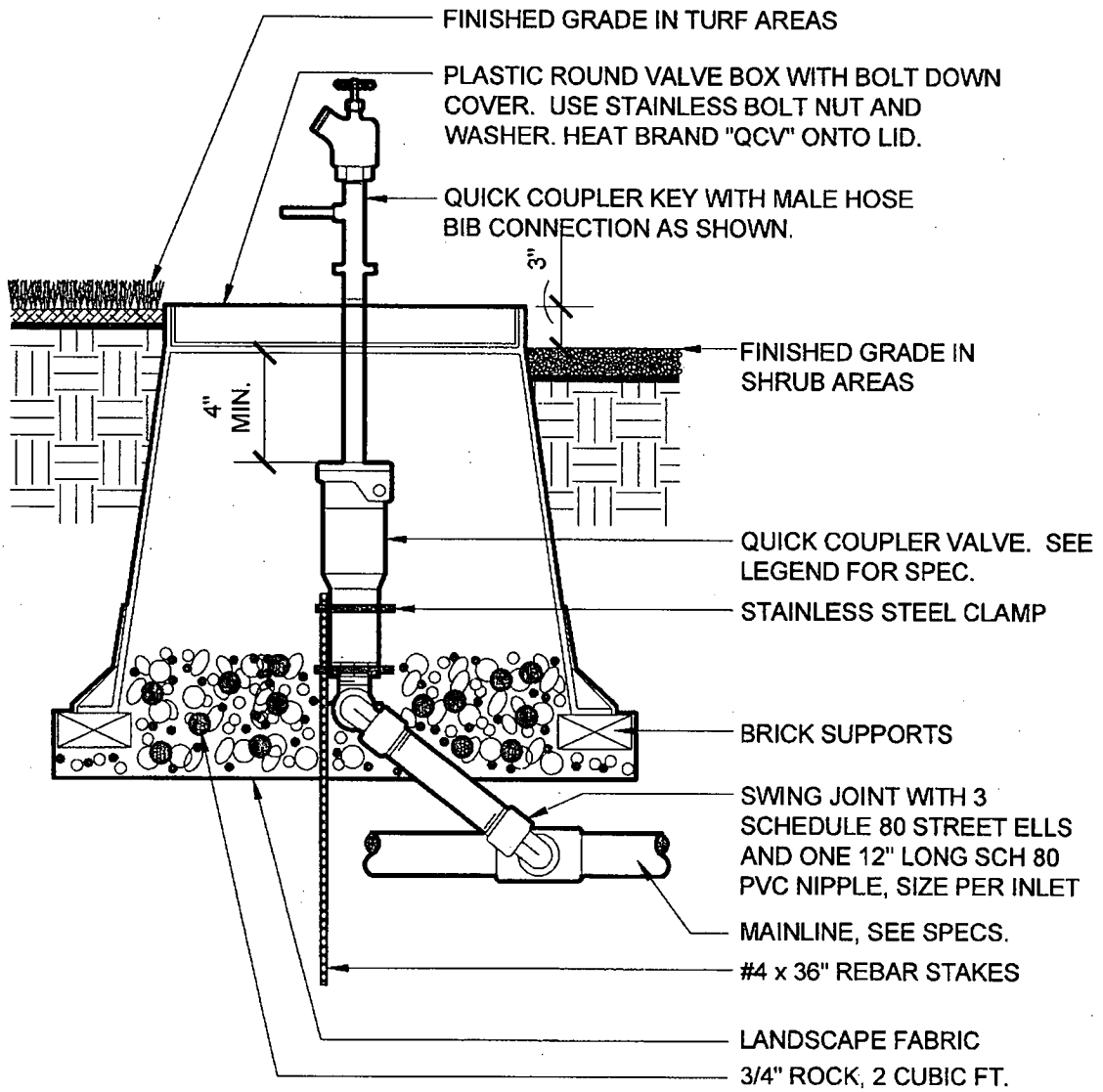

NOTES:

1. USE TEFLON TAPE ON ALL THREADED FITTINGS TYPICAL UNLESS PROHIBITED BY MANUFACTURER.
2. QUICK COUPLER KEY MUST CLEAR VALVE BOX.



CITY OF TEMPE / PUBLIC WORKS DEPARTMENT

NOT TO SCALE

QUICK COUPLER VALVE
INSTALLED IN VALVE BOX

T-721

APPROVED: _____

DEPUTY PUBLIC WORKS DIRECTOR / CITY ENGINEER

7/21/11
DATE

REVISED JULY 2011

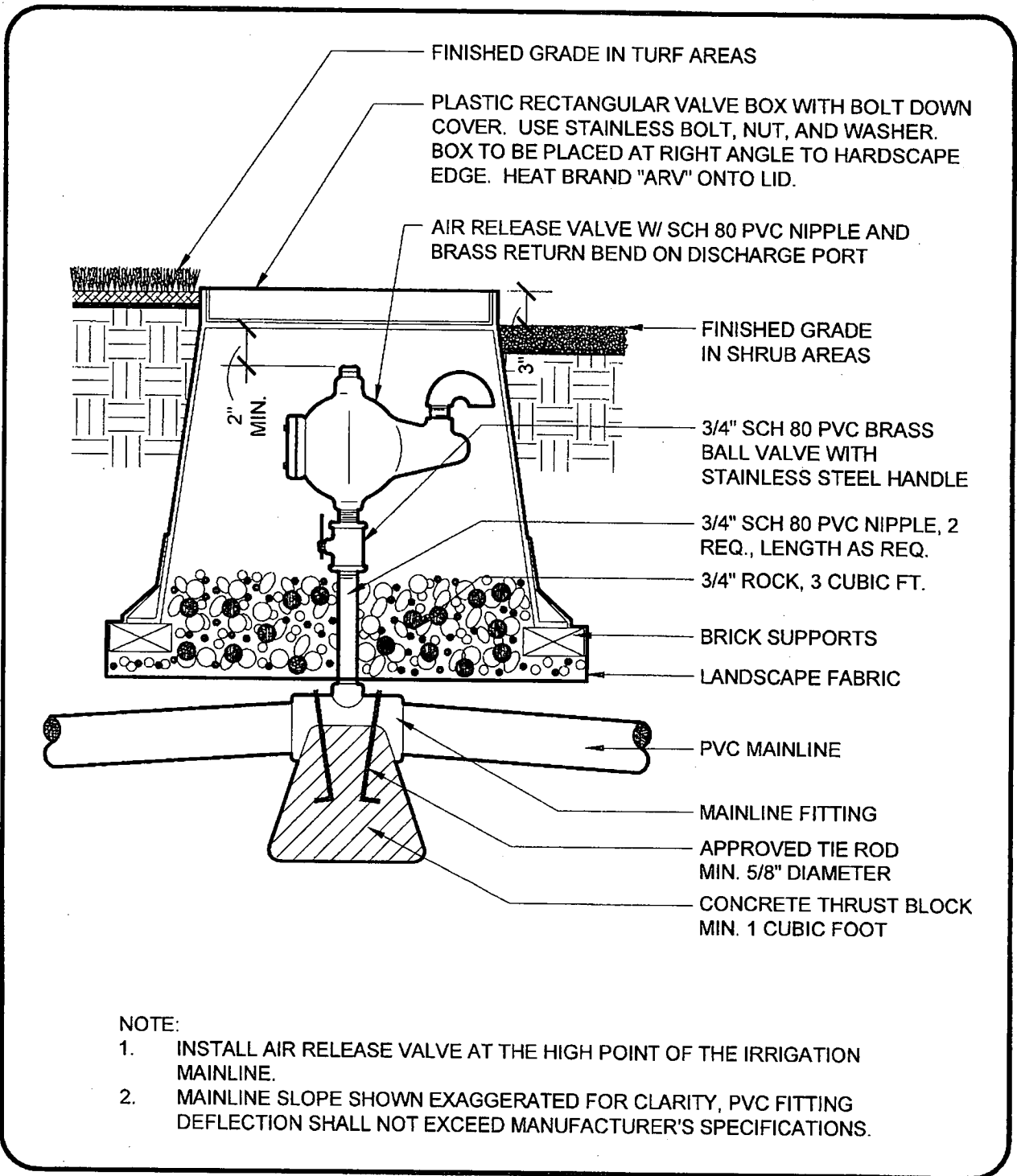

	CITY OF TEMPE / PUBLIC WORKS DEPARTMENT	NOT TO SCALE
	<h2 style="margin: 0;">AIR RELEASE VALVE INSTALLED IN BOX</h2>	
	APPROVED: <u>Andy</u> <small>DEPUTY PUBLIC WORKS DIRECTOR / CITY ENGINEER</small>	<u>7/21/11</u> <small>DATE</small>

REVISED JULY 2011

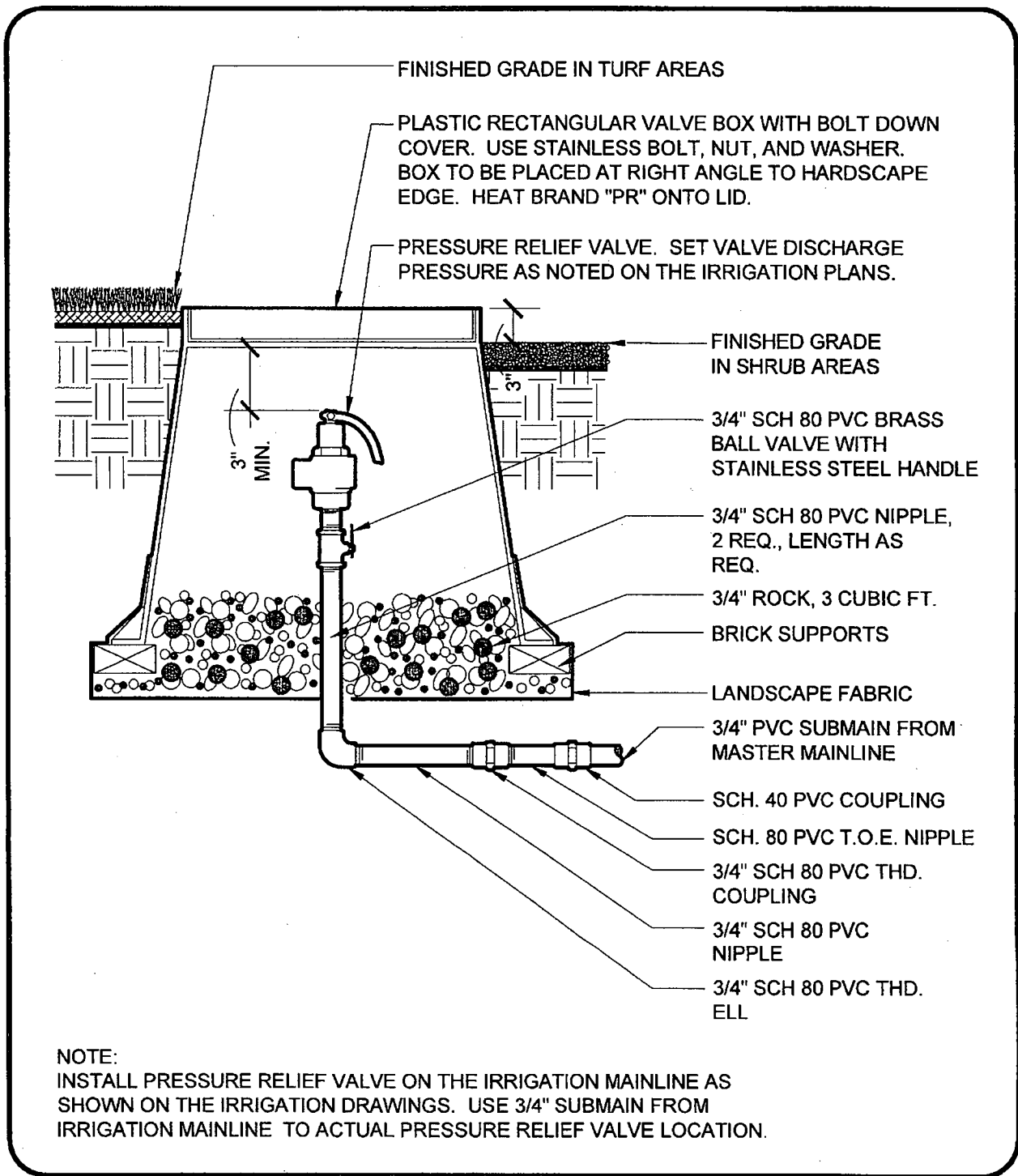

	CITY OF TEMPE / PUBLIC WORKS DEPARTMENT	NOT TO SCALE
	<h2 style="margin: 0;">PRESSURE RELIEF VALVE INSTALLED IN BOX</h2>	
	APPROVED: <u>Andy</u> <small>DEPUTY PUBLIC WORKS DIRECTOR / CITY ENGINEER</small>	DATE: <u>7/21/11</u>

REVISED JULY 2011

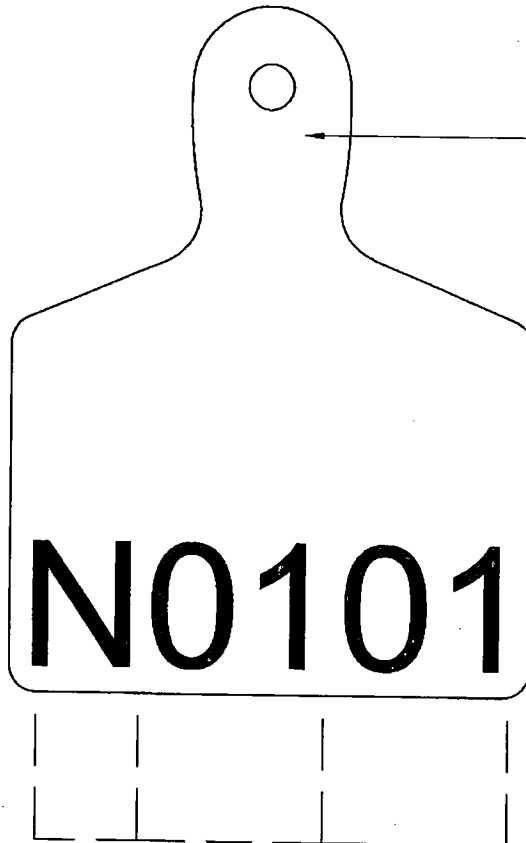

T. CHRISTY ID-MAX-Y1
REMOTE CONTROL
VALVE ID TAG OR
APPROVED EQUAL

CCU SATELLITE STATION
 NUMBER NUMBER



CITY OF TEMPE / PUBLIC WORKS DEPARTMENT

NOT TO SCALE

REMOTE CONTROL
VALVE ID TAG

T-724

APPROVED: _____

Andy

7/21/11

DEPUTY PUBLIC WORKS DIRECTOR / CITY ENGINEER

DATE

REVISED JULY 2011

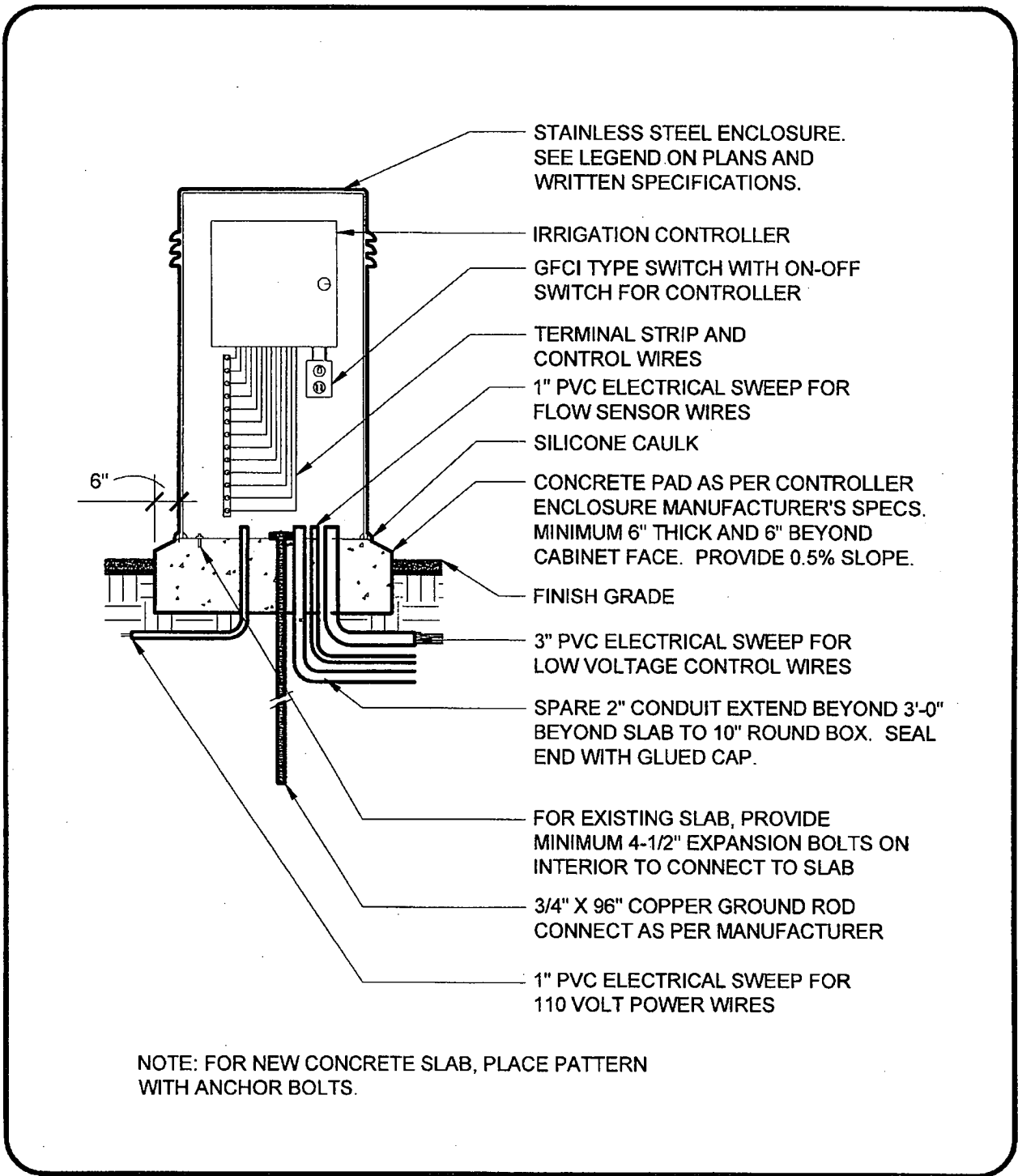

	CITY OF TEMPE / PUBLIC WORKS DEPARTMENT	NOT TO SCALE
	<h2 style="margin: 0;">IRRIGATION CONTROLLER IN ENCLOSURE</h2>	
	APPROVED: <u>Andy</u> <small>DEPUTY PUBLIC WORKS DIRECTOR / CITY ENGINEER</small>	<u>7/21/10</u> <small>DATE</small>

REVISED JULY 2011

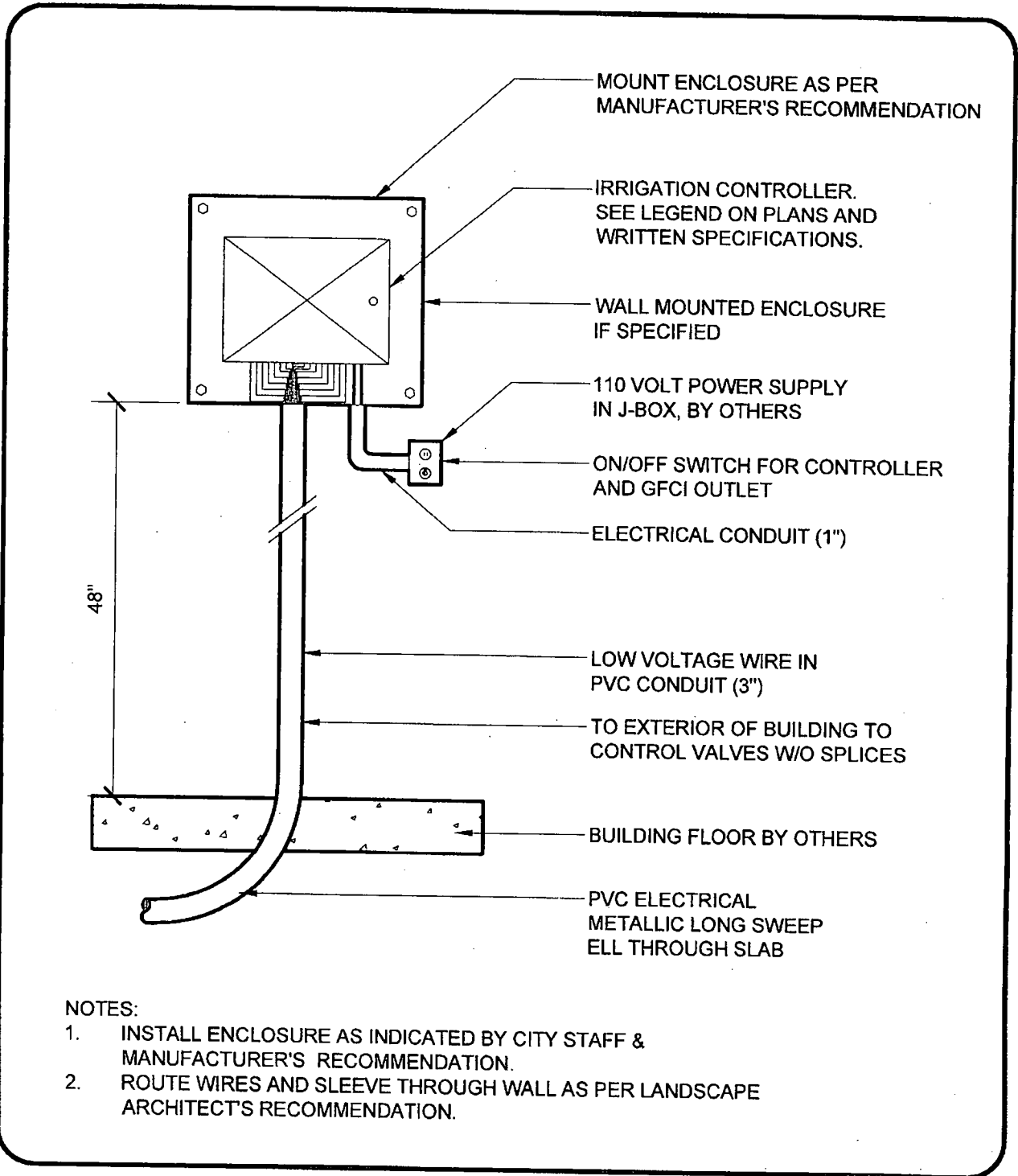

	CITY OF TEMPE / PUBLIC WORKS DEPARTMENT	NOT TO SCALE
	IRRIGATION CONTROLLER WALL MOUNT INTERIOR	
	APPROVED: <u>Andy</u> <small>DEPUTY PUBLIC WORKS DIRECTOR / CITY ENGINEER</small>	<u>7/21/11</u> <small>DATE</small>

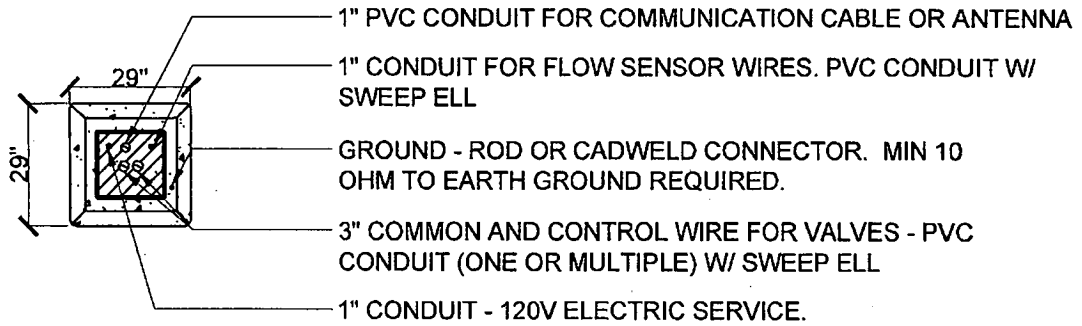

PEDESTAL MOUNTING CONCRETE PAD (PLAN VIEW)

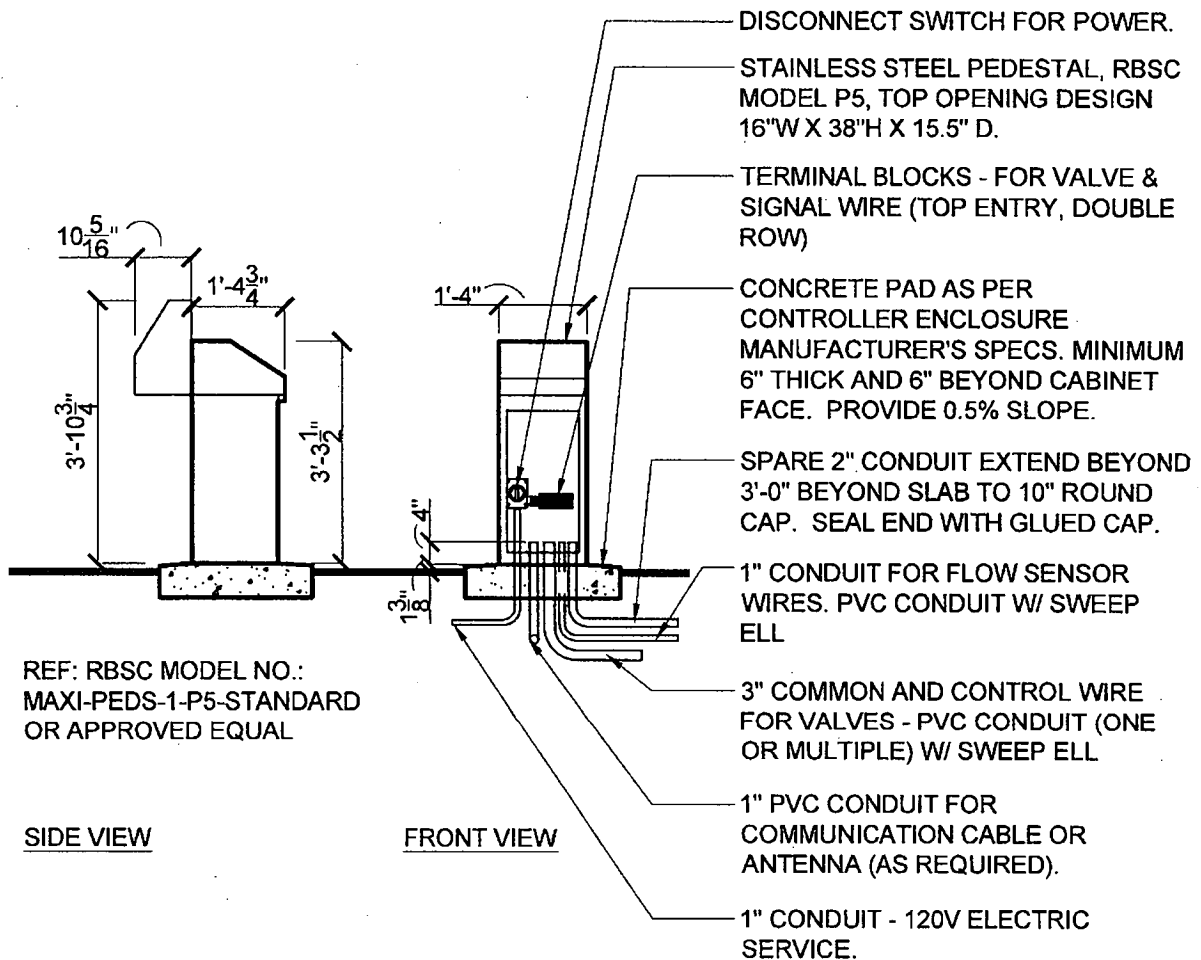

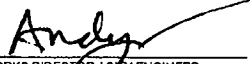
	CITY OF TEMPE / PUBLIC WORKS DEPARTMENT	NOT TO SCALE
	FLIP-TOP CABINET	
	APPROVED:  <small>DEPUTY PUBLIC WORKS DIRECTOR / CITY ENGINEER</small>	7/21/11 <small>DATE</small>
REVISED JULY 2011		

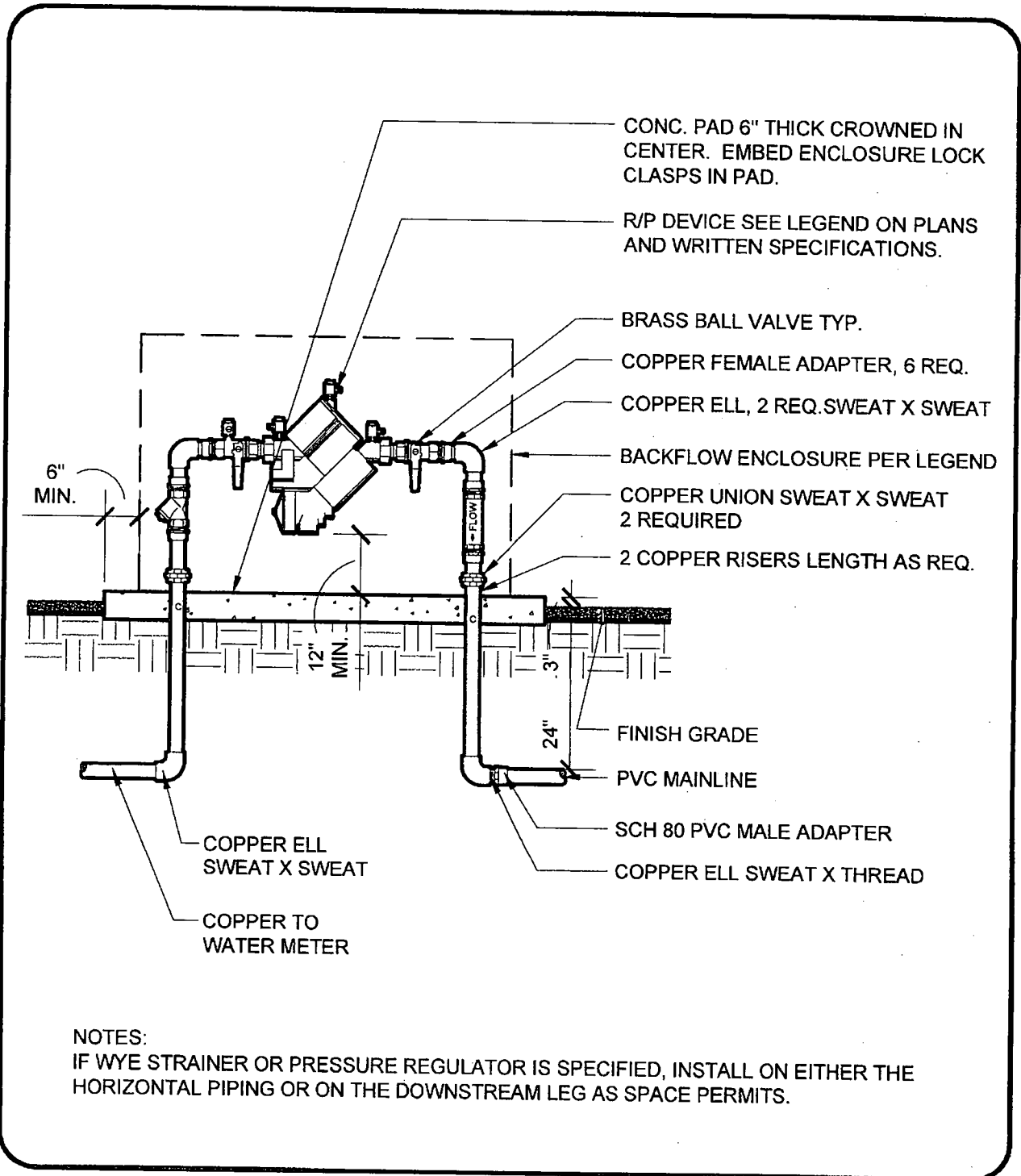

	CITY OF TEMPE / PUBLIC WORKS DEPARTMENT	NOT TO SCALE
	BACKFLOW PREVENTER WITH ENCLOSURE 2" DIA. & SMALLER	
	APPROVED: <i>Andy</i> <small>DEPUTY PUBLIC WORKS DIRECTOR / CITY ENGINEER</small>	7/21/11 <small>DATE</small>

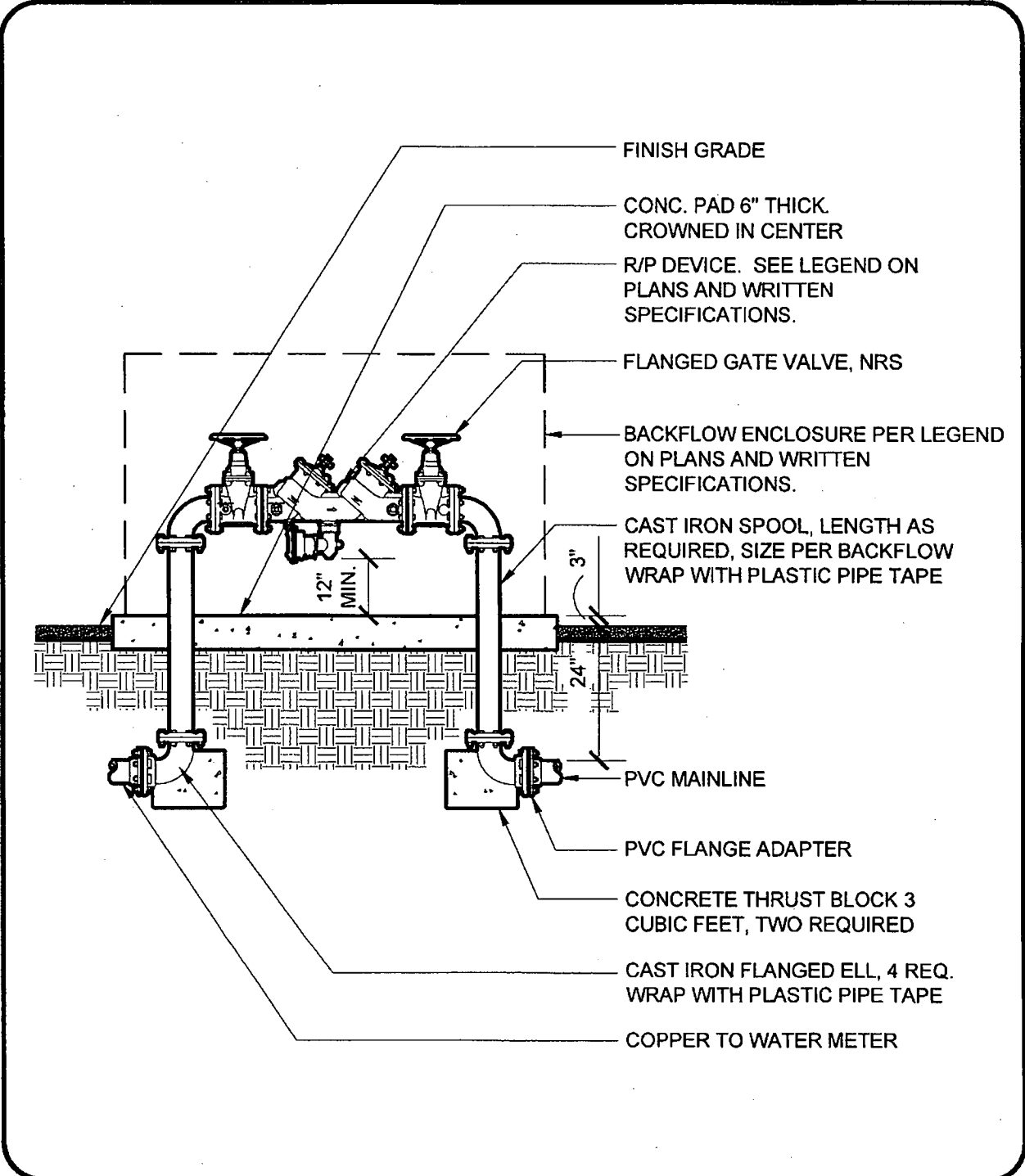

	CITY OF TEMPE / PUBLIC WORKS DEPARTMENT	NOT TO SCALE
	BACKFLOW PREVENTER WITH ENCLOSURE 2-1/2" DIA. OR LARGER	
	APPROVED: <u><i>Andy</i></u> <small>DEPUTY PUBLIC WORKS DIRECTOR / CITY ENGINEER</small>	<u>7/21/11</u> <small>DATE</small>

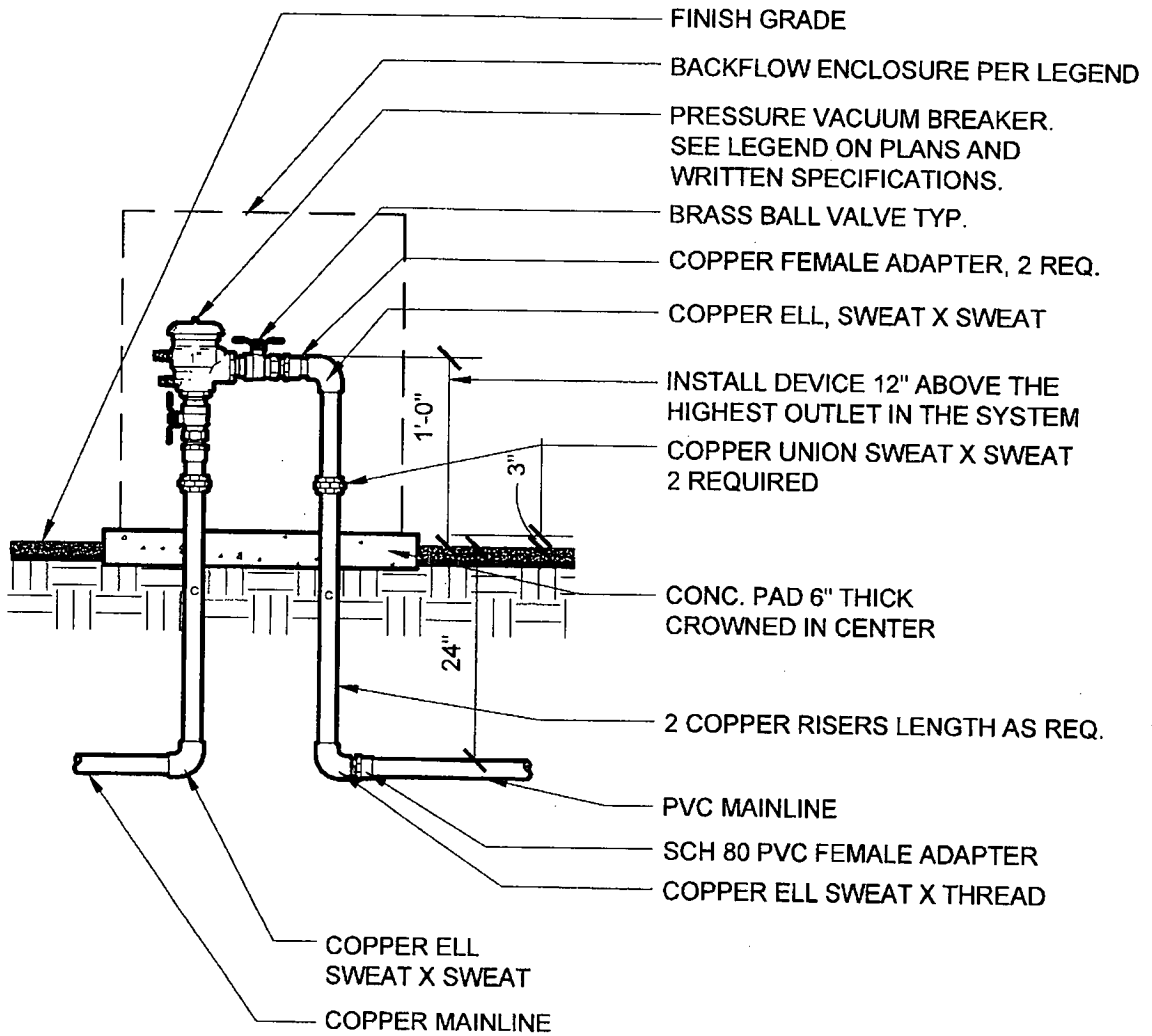

NOTES:
 IF WYE STRAINER OR PRESSURE REGULATOR IS SPECIFIED, INSTALL ON EITHER THE HORIZONTAL PIPING OR ON THE DOWNSTREAM LEG AS SPACE PERMITS.



CITY OF TEMPE / PUBLIC WORKS DEPARTMENT

NOT TO SCALE

**PRESSURE VACUUM BREAKER W/
 ENCLOSURE 2" DIA. & SMALLER**

T-730

APPROVED: _____

DEPUTY PUBLIC WORKS DIRECTOR / CITY ENGINEER

Andy

7/21/11

DATE

REVISED JULY 2011

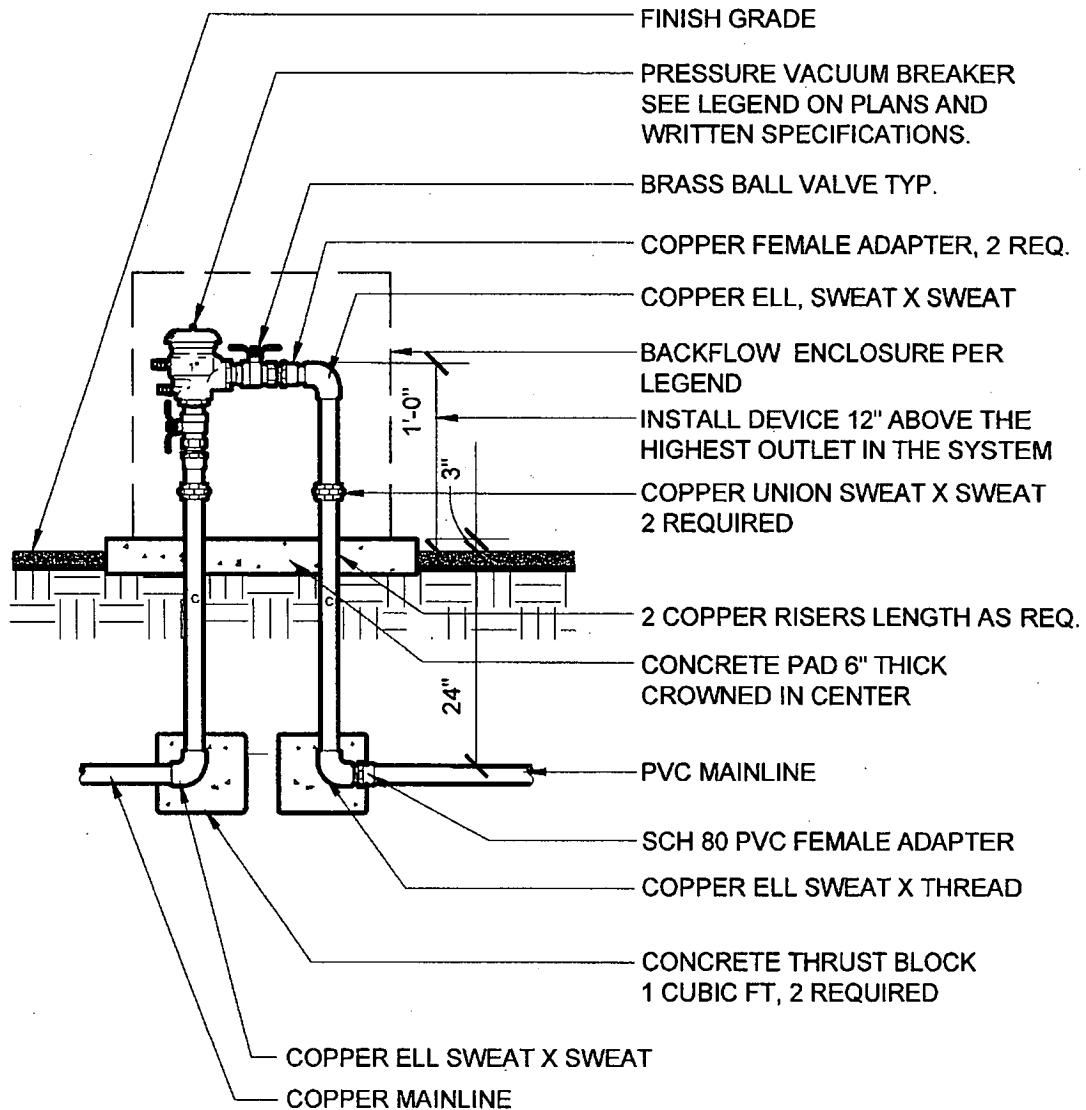

NOTES:
IF WYE STRAINER OR PRESSURE REGULATOR IS SPECIFIED, INSTALL ON EITHER THE
HORIZONTAL PIPING OR ON THE DOWNSTREAM LEG AS SPACE PERMITS.



CITY OF TEMPE / PUBLIC WORKS DEPARTMENT

NOT TO SCALE

**PRESSURE VACUUM BREAKER
W/ ENCLOSURE 2" DIA. & LARGER**

T-731

APPROVED: Andy
DEPUTY PUBLIC WORKS DIRECTOR / CITY ENGINEER

7/21/11
DATE

REVISED JULY 2011

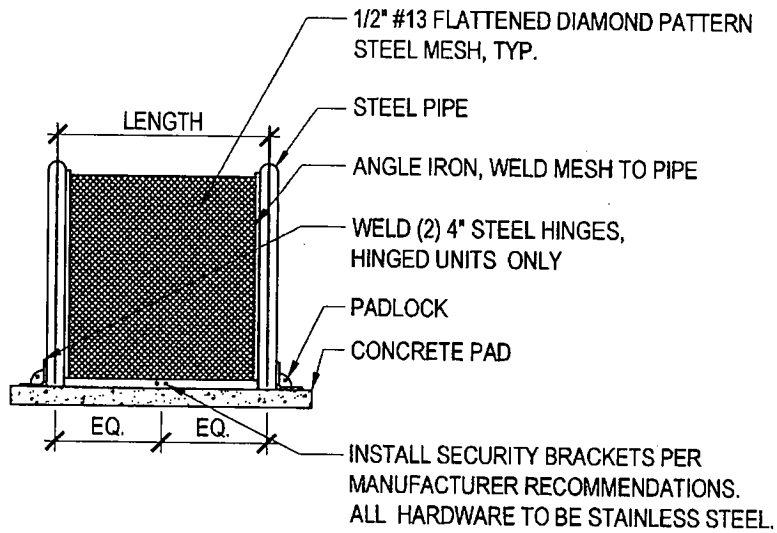
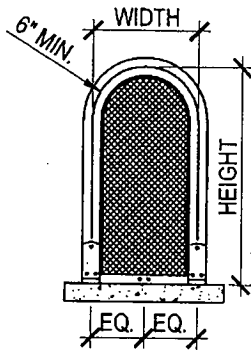

STD. SIZE	CENTERLINE DIMENSIONS	TYPE
GS-5	12"W X 18"H X 12"L	LIFT OFF UNIT
GS-1	12"W X 24"H X 24"L	LIFT OFF UNIT
GS-2	12"W X 24"H X 32"L	LIFT OFF UNIT
GS-3	12"W X 24"H X 42"L	HINGED UNIT
GS-3.5	12"W X 30"H X 42"L	HINGED UNIT
GS-4	18"W X 30"H X 48"L	HINGED UNIT



CITY OF TEMPE / PUBLIC WORKS DEPARTMENT

NOT TO SCALE

ENCLOSURE CAGE FOR BACKFLOW PREVENTER

T-732

APPROVED: _____

DEPUTY PUBLIC WORKS DIRECTOR / CITY ENGINEER

7/21/11
DATE

REVISED JULY 2011

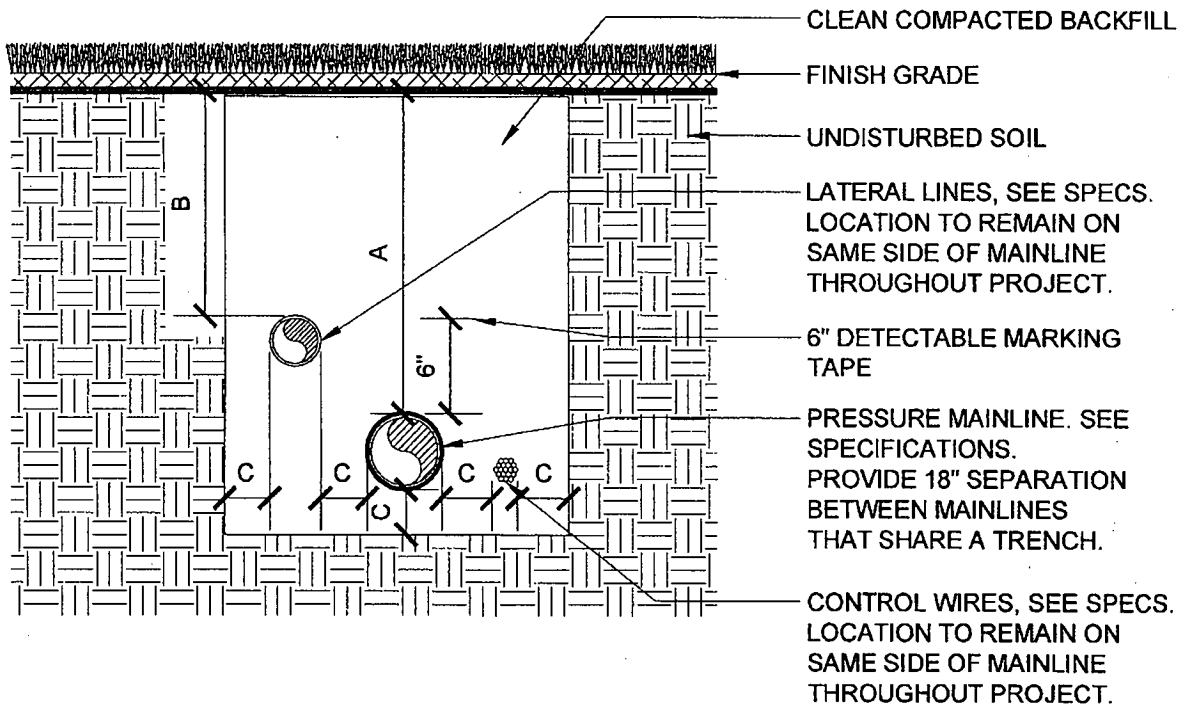

DIMENSION	A	B	C
LATERAL PIPE 1/2" TO 3"	X	18"	4"
LATERAL PIPE IN SPORTS FIELDS 1" TO 3"	X	18"	4"
MAINLINE PIPE 2" TO 12"	24"	X	4"
CONTROL WIRE CONDUIT	24"	X	4"

NOTES:

1. ALL PLASTIC PIPING SHALL BE SNAKED WITHIN TRENCH.
2. BUNDLE WIRING AND WRAP WITH TAPE AT TEN FOOT INTERVALS.
3. ALL MAINLINE PIPING TO BE INSTALLED IN ACCORDANCE WITH MANUFACTURERS INSTALLATION SPECIFICATIONS.
4. PROVIDE 18" SEPARATION BETWEEN MAIN LINES THAT SHARE A TRENCH.



CITY OF TEMPE / PUBLIC WORKS DEPARTMENT

NOT TO SCALE

PIPE AND WIRE TRENCHING

T-733

APPROVED: Andy
DEPUTY PUBLIC WORKS DIRECTOR / CITY ENGINEER

7/24/11
DATE

REVISED JULY 2011

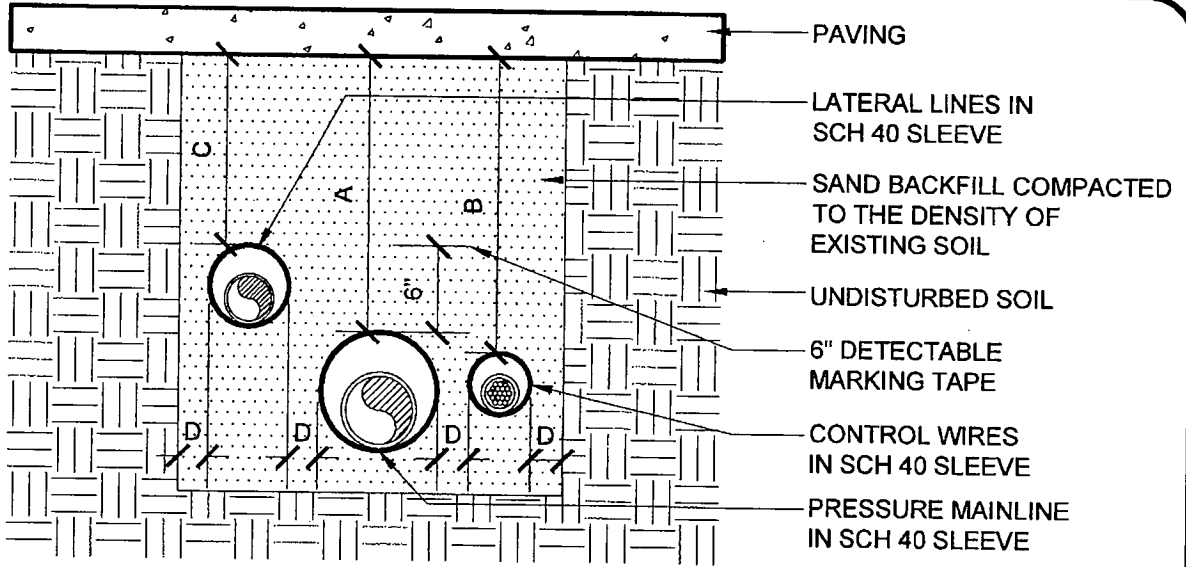

DIMENSION	A	B	C	D
PAVED AREA / DRIVEWAY	36"	36"	24"	4"
PUBLIC ROADS	36"	36"	36"	4"

PVC SLEEVES TO BE TWICE THE DIAMETER OF THE PIPE OR WIRE BUNDLE CARRIED.

DETAIL ALSO FOR PIPE INSTALLED IN ROCK SOIL.

SECTION VIEW - N.T.S.

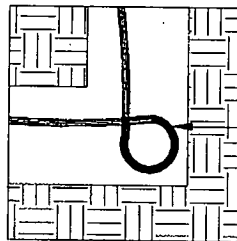

TIE A 24" LOOP IN ALL WIRING AT CHANGES OF DIRECTION GREATER THAN 30 DEGREES, UNTIE AFTER ALL CONFECTIONS HAVE BEEN MADE.

PLAN VIEW - N.T.S.

NOTES:

- BUNDLE WIRING AND WRAP WITH ELECTRICAL TAPE AT TEN FOOT INTERVALS.
- ALL MAINLINE PIPING TO BE INSTALLED IN ACCORDANCE WITH MANUFACTURERS INSTALLATION SPECIFICATIONS.
- ALL PVC MAINLINE, PVC LATERAL LINES, AND CONTROL WIRES SHALL BE SLEEVED BELOW ALL HARDSCAPE ELEMENTS WITH SCH 40 PVC, 2 TIMES THE DIAMETER OF THE PIPE OR WIRE BUNDLE WITHIN.
- ALL CURBS SHALL BE MARKED WITH A "SCORE" MARK TO DESIGNATE SLEEVE LOCATION, TYPICAL.



CITY OF TEMPE / PUBLIC WORKS DEPARTMENT

NOT TO SCALE

SLEEVE TRENCHING

T-734

APPROVED:

DEPUTY PUBLIC WORKS DIRECTOR / CITY ENGINEER

Andy

7/21/11

DATE

REVISED JULY 2011

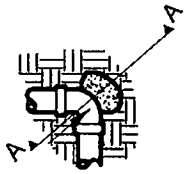

90° BEND

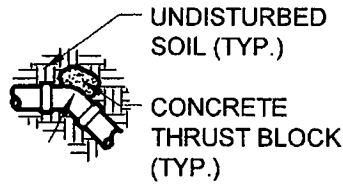

11-1/4°, 22-1/2°
OR 45° BENDS

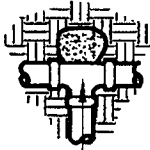
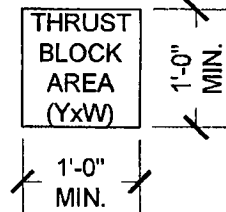

TEE

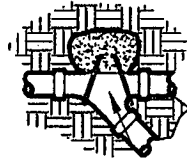

WYE

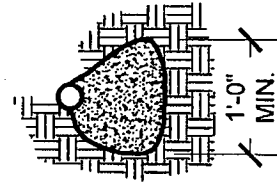

TYPICAL SECTION A-A

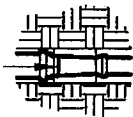

REDUCER

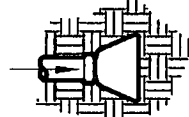

DEAD END

MINIMUM THRUST BLOCK AREA (Y X W)		
PIPE SIZE	IRRIGATION PIPE	
	TEE, DEAD END & 90° BEND	11-1/4°, 22-1/2° OR 45° BENDS
2-1/2" & LESS	2-1/2" & LESS	NOT REQUIRED
3"	1.5 S.F.	1.5 S.F.
4"	2.6 S.F.	1.5 S.F.
6"	5.3 S.F.	3.0 S.F.
8"	10.0 S.F.	5.5 S.F.
10" & LARGER	PER MAG DETAIL 380	PER MAG DETAIL 380

NOTES:

1. MINIMUM THRUST BLOCK AREAS AREA BASED ON A SOIL BEARING CAPACITY OF 1,500 LBS/S.F. AND A STATIC WATER PRESSURE OF 100 PSI.
2. MINIMUM THRUST BLOCK AREAS ARE GIVEN FOR HORIZONTAL THRUSTS WITH 24" MINIMUM DEPTH OF COVER OVER TOP OF PIPE.
3. THRUST BLOCK SHALL EXTEND INTO UNDISTURBED SOIL.
4. THRUST BLOCK CONCRETE SHALL BE MAG SECT. 725 - CLASS C.
5. FOR REDUCERS, SUBTRACT SMALL OPENING PLUG THRUST FROM LARGE OPENING PLUG THRUST TO CALCULATE THRUST PER 100 PSI WORKING PRESSURE.
6. INSTALL 30 MIL PVC LINER BETWEEN ALL FITTINGS AND CONCRETE THRUST BLOCKS.
7. DESIGNER TO VERIFY SIZING AT THRUST BLOCKS.



CITY OF TEMPE / PUBLIC WORKS DEPARTMENT

NOT TO SCALE

THRUST BLOCKS

T-735

APPROVED: _____

DEPUTY PUBLIC WORKS DIRECTOR / CITY ENGINEER

7/21/11
DATE

REVISED JULY 2011

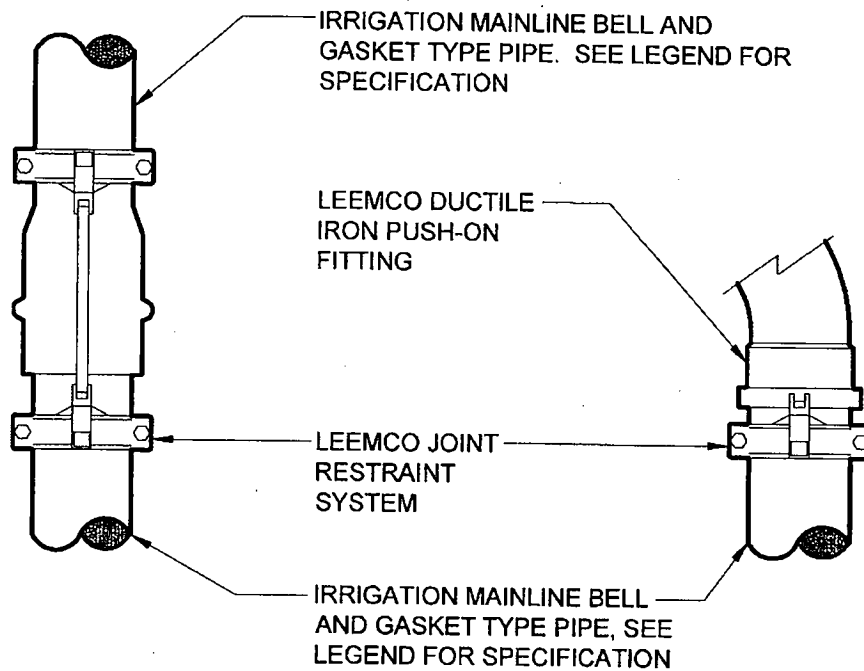

NOTES:

1. USE THRUST BLOCKS ON ALL SOLVENT WELD MAINLINE PIPE.
2. USE JOINT RESTRAINTS ON ALL BELL AND GASKET MAINLINE PIPE.
3. USE LEEMCO PIPE RESTRAINTS ON ALL FITTINGS AT DIRECTIONAL CHANGES IN PIPE AND AT ALL COUPLINGS WITHIN 50 FEET OF THE DIRECTIONAL CHANGE. USE LEEMCO PIPE RESTRAINTS AND PUSH-ON FITTINGS TO CONNECT ISOLATION VALVES, REMOTE CONTROL VALVES AND QUICK COUPLERS TO THE MAINLINE.
4. SIZE OF RESTRAINT TO BE AS PER PIPE AND FITTING USED.
5. USE LB SERIES RESTRAINTS FOR BELL AND GASKET JOINTS.
6. USE LH SERIES RESTRAINTS FOR PVC PIPE TO DUCTILE IRON PUSH-ON FITTINGS.
7. USE LG SERIES RESTRAINTS FOR BUTTERFLY AND GATE VALVES.



CITY OF TEMPE / PUBLIC WORKS DEPARTMENT

NOT TO SCALE

PIPE RESTRAINT SYSTEM

T-736

APPROVED: _____

DEPUTY PUBLIC WORKS DIRECTOR / CITY ENGINEER

Andy

7/21/11

DATE

REVISED JULY 2011

1. STRIP ENDS OF WIRE

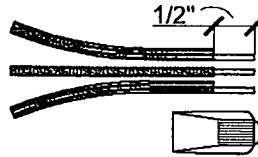

2. SECURE WIRES INTO WIRE NUT

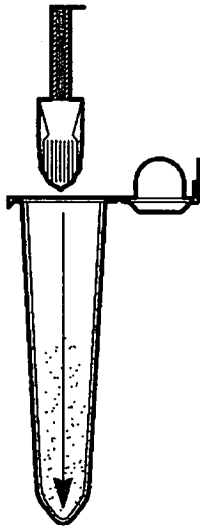

3. INSERT WIRE NUT INTO GEL-FILLED TUBE

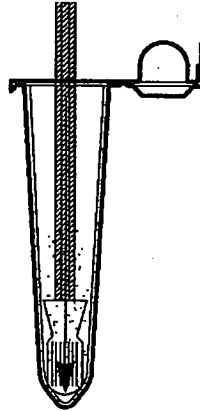

4. POSITION WIRES INTO CHANNELS

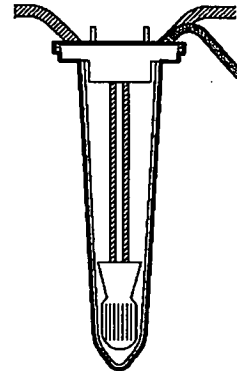

5. CLOSE SPLICE KIT FOR SECURED SEAL

NOTES:

1. VISUALLY CHECK THAT CONNECTOR IS BELOW LOCKING "FINGERS"
2. SPLICE KIT SHALL BE "SURESPlice SK 14-12G" AS MANUFACTURED BY NORTHSTAR INDUSTRIES OR APPROVED EQUAL.



CITY OF TEMPE / PUBLIC WORKS DEPARTMENT

NOT TO SCALE

WIRE CONNECTOR

T-737

APPROVED:

Andy
DEPUTY PUBLIC WORKS DIRECTOR / CITY ENGINEER

7/24/11
DATE

REVISED JULY 2011

1. GROUP ENDS OF WIRE

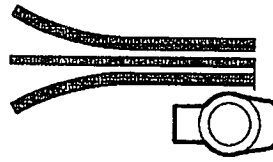

2. SECURE WIRES INTO 3M-UAL WIRE CONNECTOR



3. INSERT 3M-UAL CONNECTOR INTO RANGER SERVICEAL SPLICE KIT



CONNECT ALL WIRES AT EACH SPLICE. ALL CONNECTIONS WITHIN 100' OF CONTROLLER SHALL BE MADE WITHIN CABINET @ TERMINALS PROVIDED.

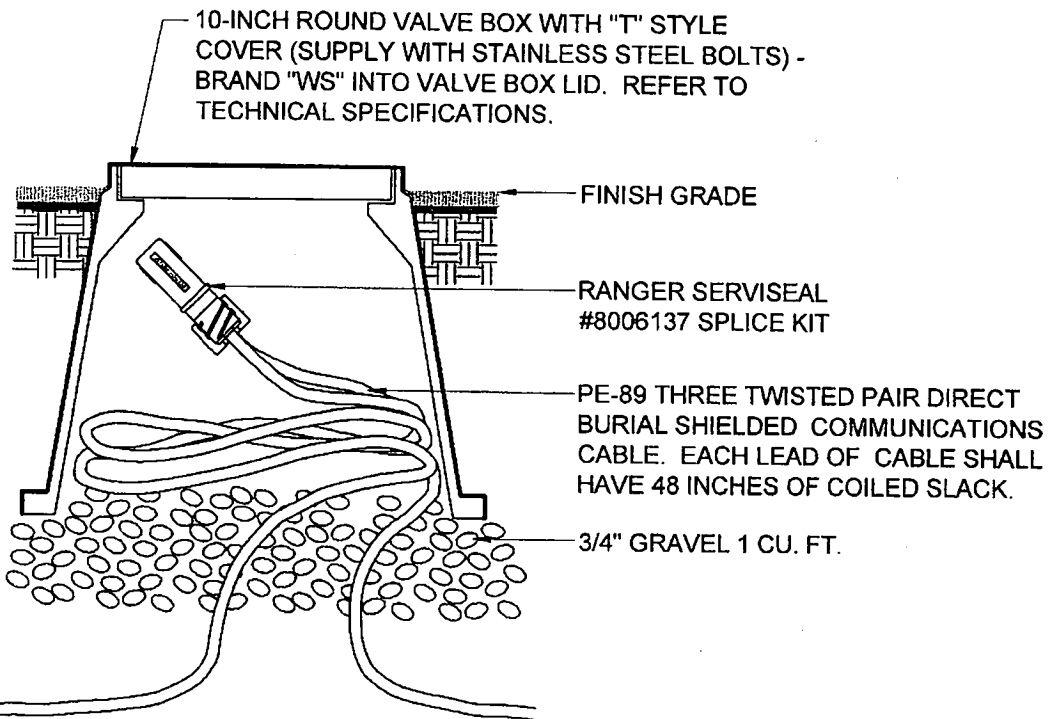

CITY OF TEMPE / PUBLIC WORKS DEPARTMENT

NOT TO SCALE

TWO CABLE WIRE SPLICE

T-738

APPROVED: _____

DEPUTY PUBLIC WORKS DIRECTOR / CITY ENGINEER

7/21/11
DATE

REVISED JULY 2011

1. GROUP ENDS OF WIRE

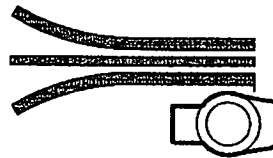

2. SECURE WIRES INTO 3M-UAL WIRE CONNECTOR



3. INSERT 3M-UAL CONNECTOR INTO SCOTCHCAST 82-B1 KIT

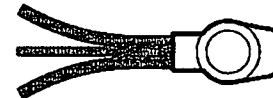

CONNECT ALL 4 WIRES AT EACH SPLICE. ALL CONNECTIONS WITHIN 100' OF CONTROLLER SHALL BE MADE WITHIN CABINET @ TERMINALS PROVIDED.

STANDARD VALVE BOX WITH "T" STYLE COVER (SUPPLY WITH STAINLESS STEEL BOLTS) - BRAND "WS" INTO VALVE BOX LID. REFER TO TECHNICAL SPECIFICATIONS.

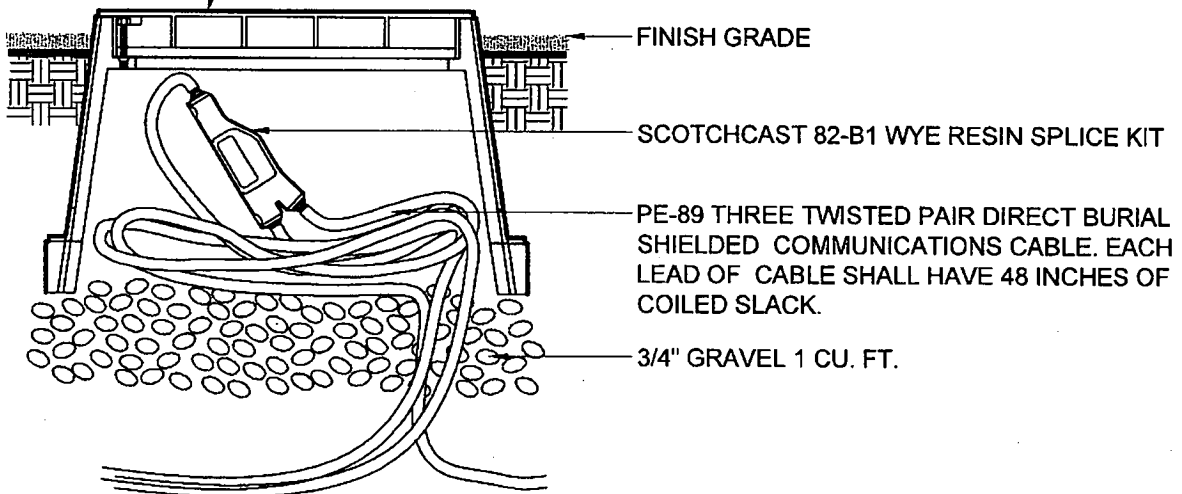

CITY OF TEMPE / PUBLIC WORKS DEPARTMENT

NOT TO SCALE



THREE CABLE WIRE SPLICE

T-739

APPROVED: _____

DEPUTY PUBLIC WORKS DIRECTOR / CITY ENGINEER

Andy

7/21/11

DATE

REVISED JULY 2011

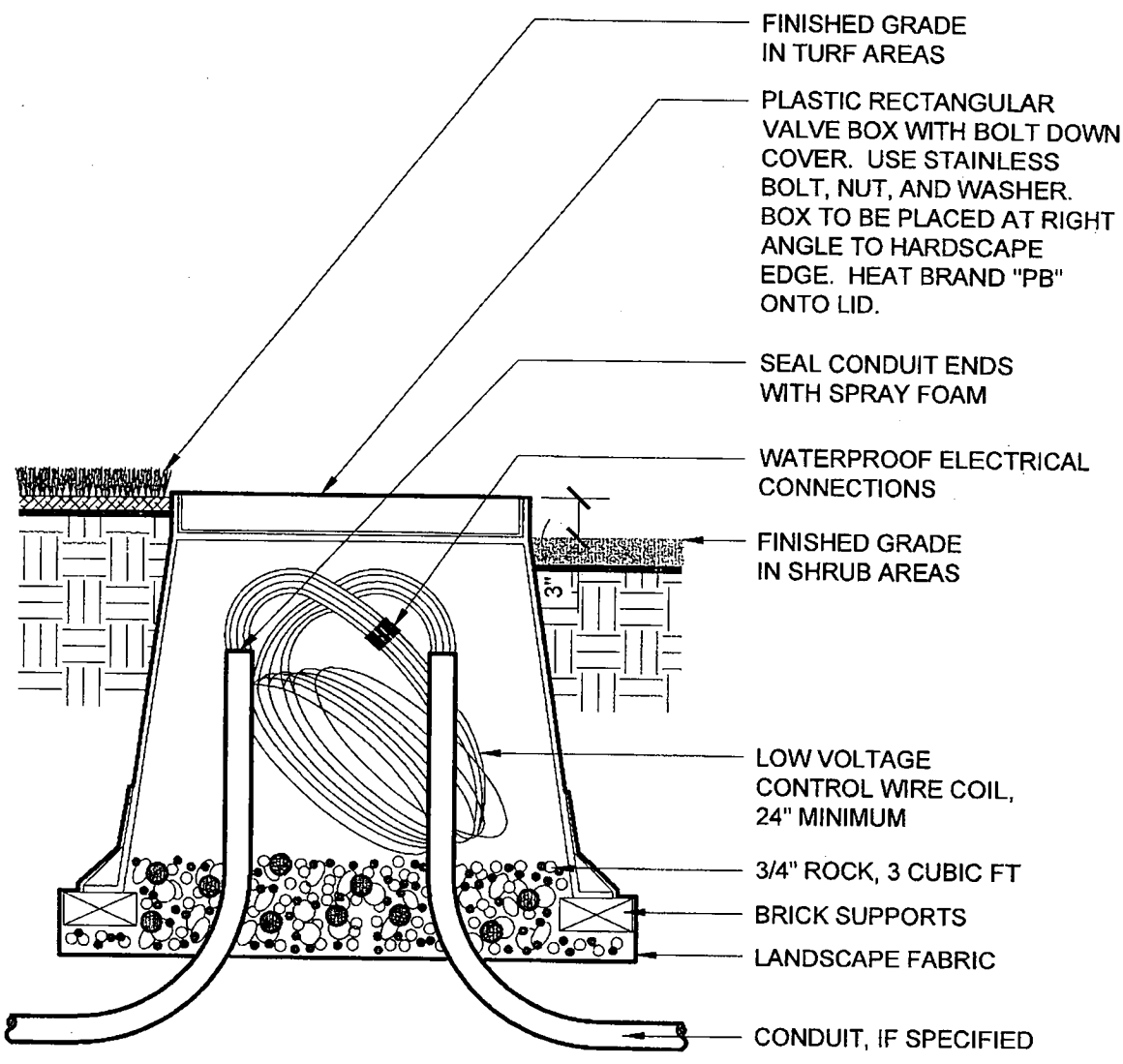

NOTES:

1. ALL CONTROL WIRE SPLICES SHALL BE INSTALLED INSIDE PULL BOXES.
2. ALL SPLICES SHALL BE MADE USING WATERPROOF ELECTRICAL CONNECTORS.
3. PULL BOX COULD BE REPLACE WITH "ELECTRIC UNDERGROUND JUNCTION BOX" PER DETAIL T-441, SHOWN OR INDICATED ON PLANS.

	CITY OF TEMPE / PUBLIC WORKS DEPARTMENT	NOT TO SCALE
	<h2 style="margin: 0;">CONTROL WIRE PULL BOX</h2>	
	APPROVED: <u>Andy</u> <small>DEPUTY PUBLIC WORKS DIRECTOR / CITY ENGINEER</small>	<u>7/21/11</u> <small>DATE</small>
REVISED JULY 2011		

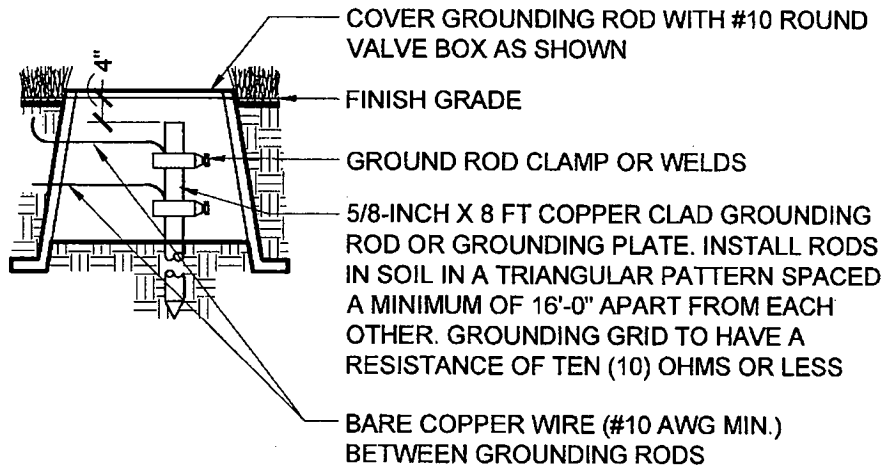

GROUND ROD ASSEMBLY

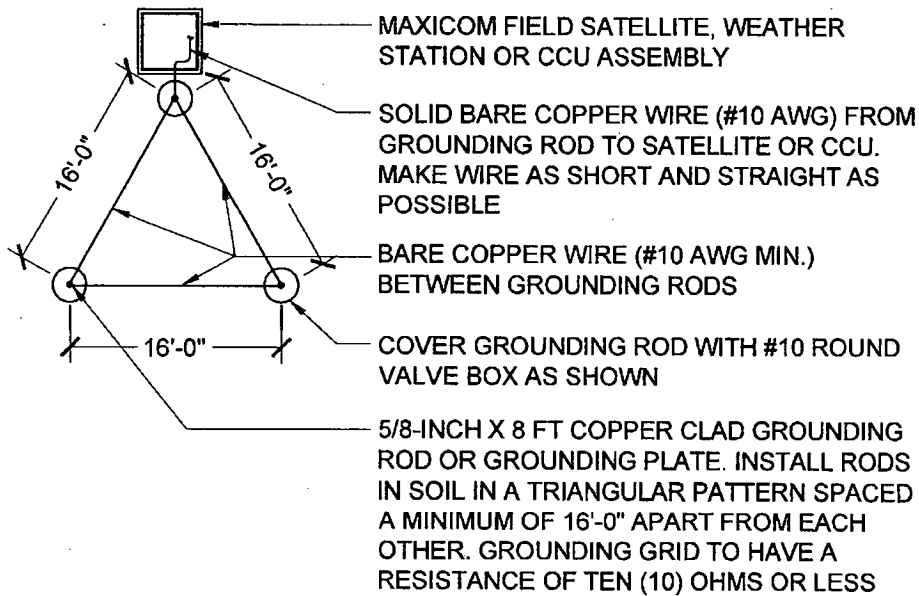

GROUND ROD LAYOUT

NOTE:
REFER TO RAIN BIRD CENTRAL CONTROL TECHNICAL BULLETIN TB-9001-MULTI FOR INSTALLATION GUIDELINES.



CITY OF TEMPE / PUBLIC WORKS DEPARTMENT

NOT TO SCALE

GROUNDING GRID

T-741

APPROVED:

DEPUTY PUBLIC WORKS DIRECTOR / CITY ENGINEER

Andy

7/21/11

DATE

REVISED JULY 2011

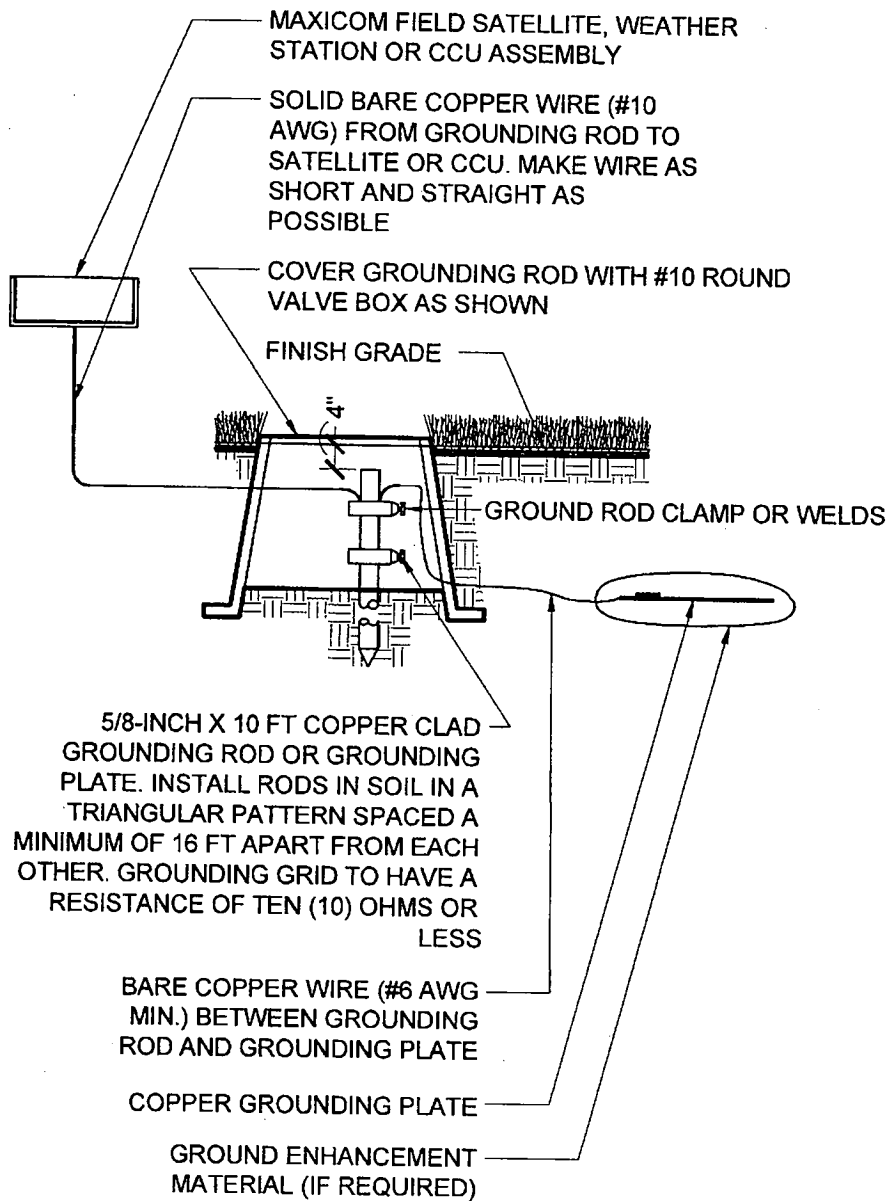

NOTE:
 REFER TO RAIN BIRD CENTRAL CONTROL TECHNICAL BULLETIN TB-9001MULTI FOR INSTALLATION GUIDELINES.



CITY OF TEMPE / PUBLIC WORKS DEPARTMENT

NOT TO SCALE

GROUNDING PLATE

T-742

APPROVED: _____

Andy

DEPUTY PUBLIC WORKS DIRECTOR / CITY ENGINEER

7/21/11

DATE

REVISED JULY 2011

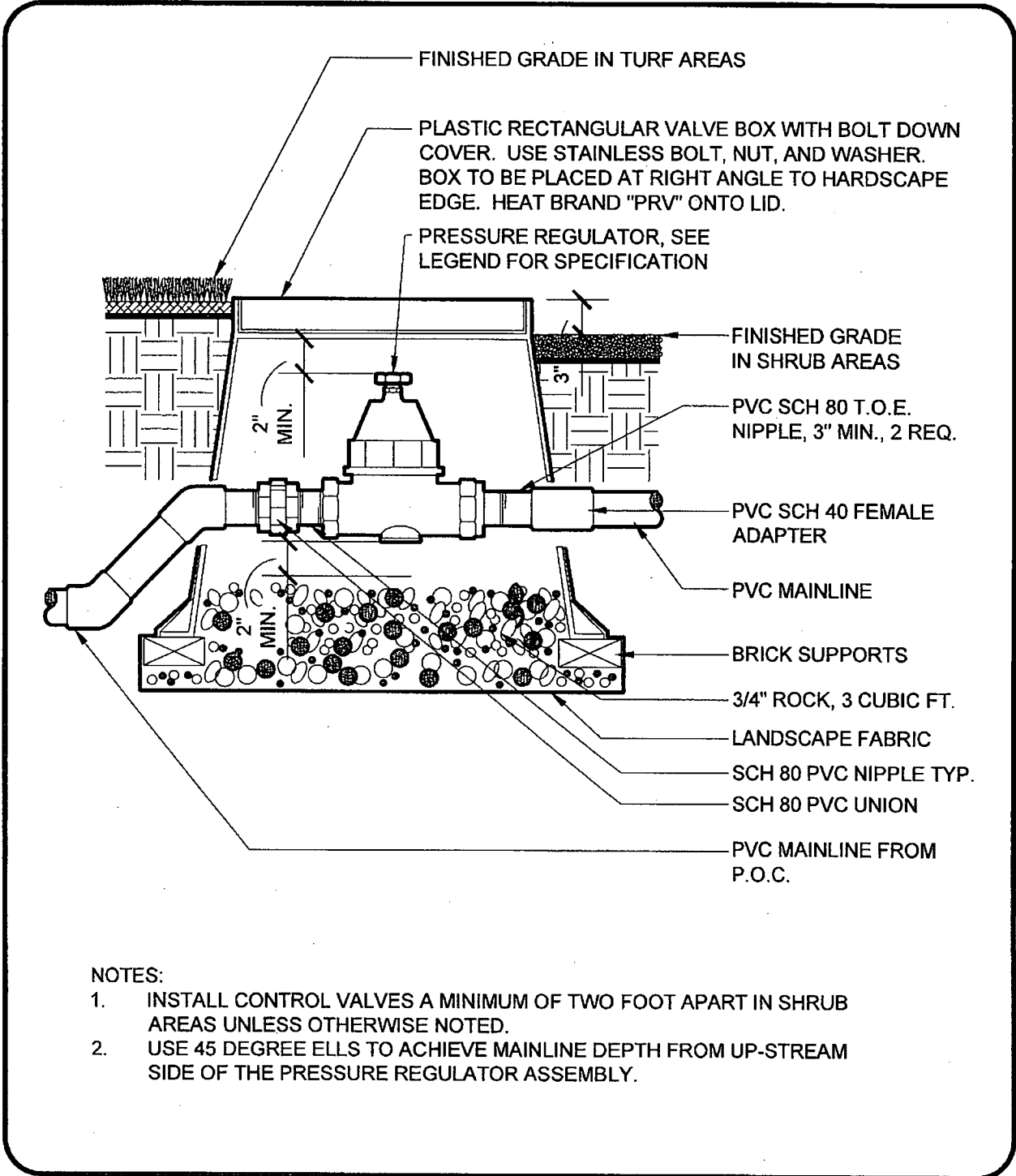

- NOTES:
1. INSTALL CONTROL VALVES A MINIMUM OF TWO FOOT APART IN SHRUB AREAS UNLESS OTHERWISE NOTED.
 2. USE 45 DEGREE ELLS TO ACHIEVE MAINLINE DEPTH FROM UP-STREAM SIDE OF THE PRESSURE REGULATOR ASSEMBLY.

	CITY OF TEMPE / PUBLIC WORKS DEPARTMENT	NOT TO SCALE
	<h1>PRESSURE REGULATOR</h1>	
	APPROVED: <u>Andy</u> <small>DEPUTY PUBLIC WORKS DIRECTOR / CITY ENGINEER</small>	DATE: <u>7/21/11</u>

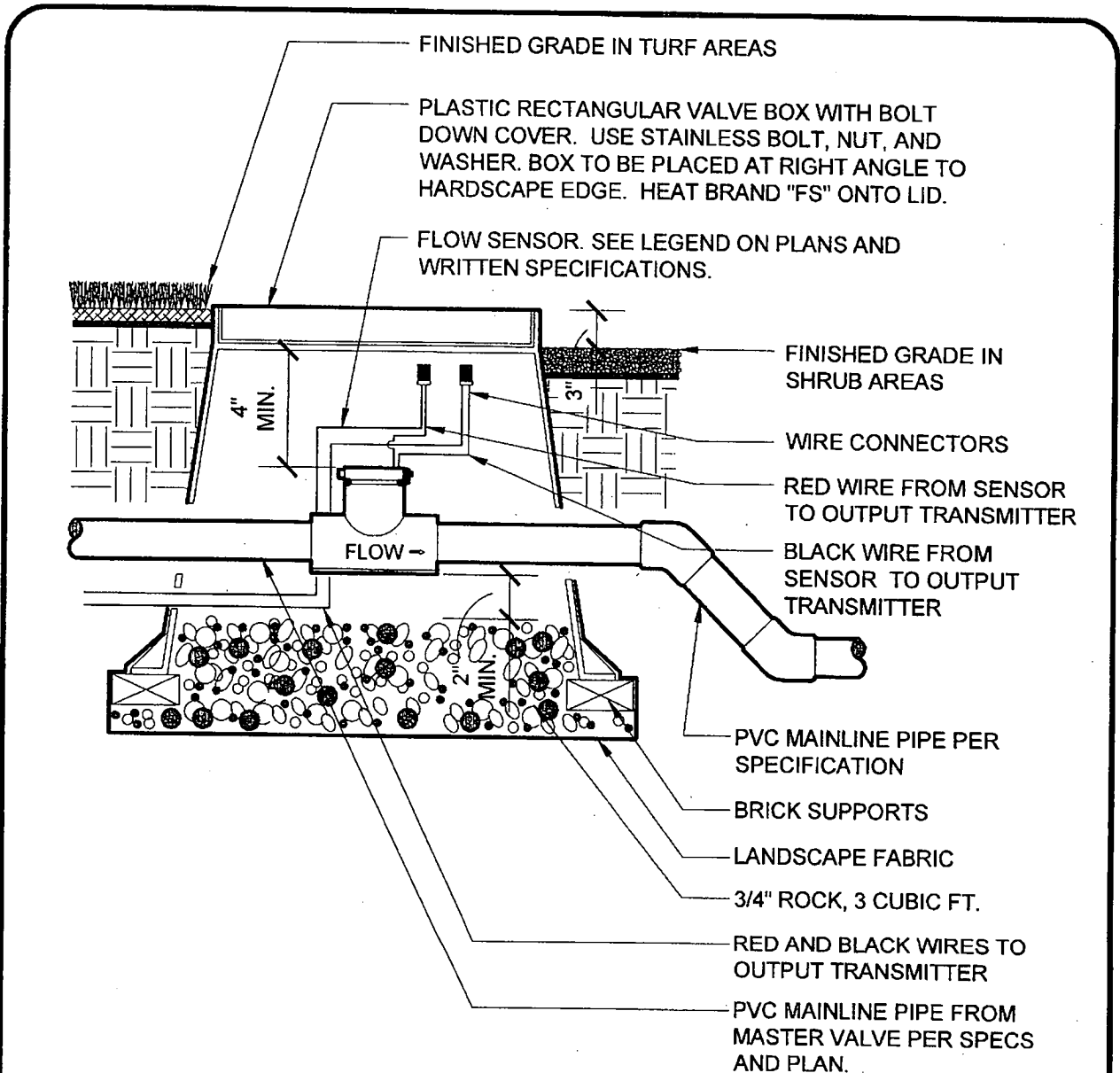



NOTES:

1. INSTALL FLOW SENSOR AS PER THE MANUFACTURER'S RECOMMENDATIONS, WIRE TO IRRIGATION CONTROLLER.
2. THE MAINLINE PIPE SHALL NOT CHANGE SIZE OR DIRECTION CLOSER THAN 10 PIPE DIAMETERS UPSTREAM OR 5 PIPE DIAMETERS DOWNSTREAM OF THE FLOW SENSOR.
3. USE 45 DEGREE ELLS TO ACHIEVE MAINLINE DEPTH ON THE DOWN-STREAM SIDE OF THE FLOW SENSOR.

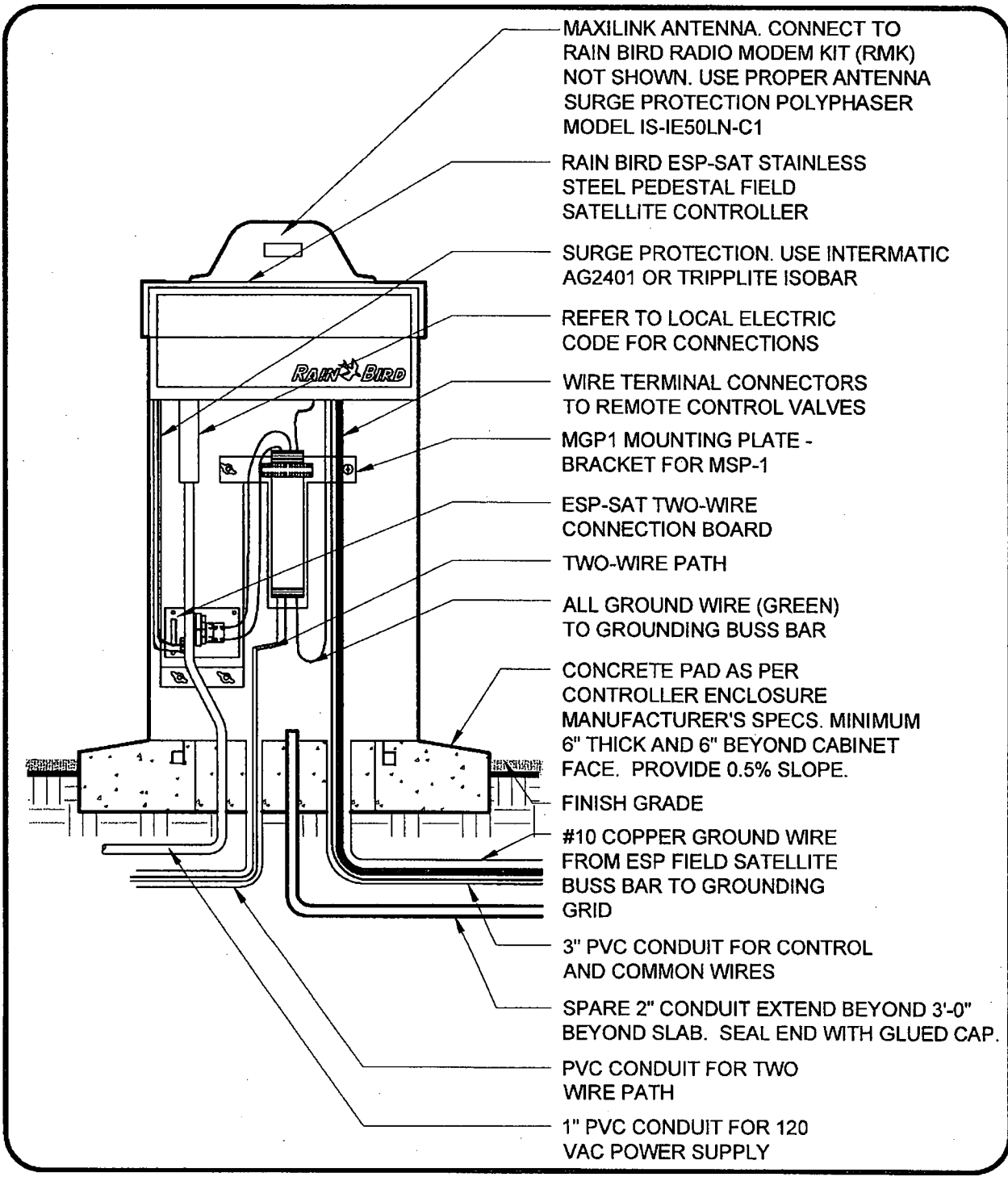
	CITY OF TEMPE / PUBLIC WORKS DEPARTMENT	NOT TO SCALE
	FLOW SENSOR	
	APPROVED: <u>Andy</u> <small>DEPUTY PUBLIC WORKS DIRECTOR / CITY ENGINEER</small>	<u>7/21/11</u> <small>DATE</small>
		REVISED JULY 2001



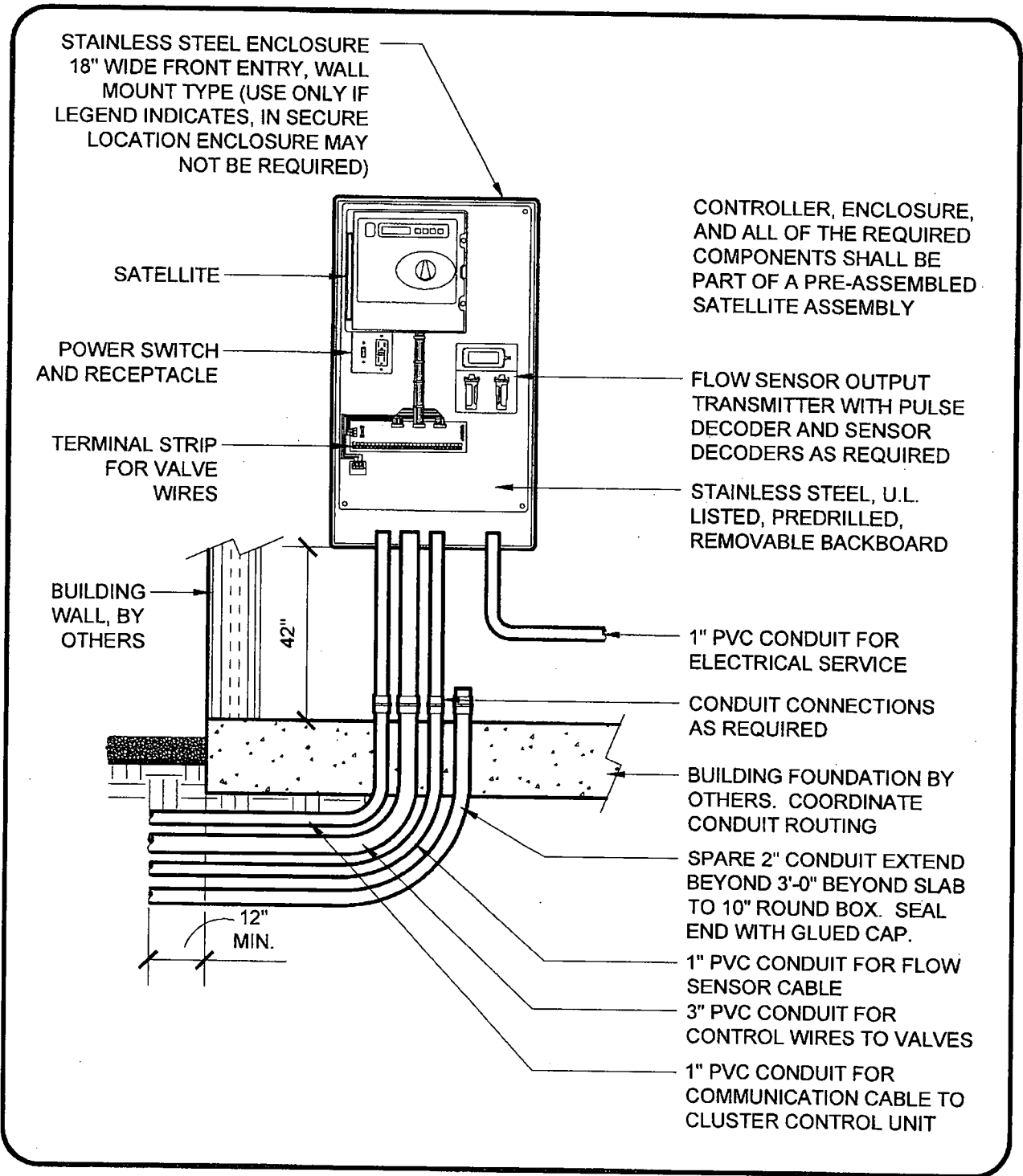

- MAXILINK ANTENNA. CONNECT TO RAIN BIRD RADIO MODEM KIT (RMK) NOT SHOWN. USE PROPER ANTENNA SURGE PROTECTION POLYPHASER MODEL IS-IE50LN-C1
- RAIN BIRD ESP-SAT STAINLESS STEEL PEDESTAL FIELD SATELLITE CONTROLLER
- SURGE PROTECTION. USE INTERMATIC AG2401 OR TRIPPLITE ISOBAR
- REFER TO LOCAL ELECTRIC CODE FOR CONNECTIONS
- WIRE TERMINAL CONNECTORS TO REMOTE CONTROL VALVES
- MGP1 MOUNTING PLATE - BRACKET FOR MSP-1
- ESP-SAT TWO-WIRE CONNECTION BOARD
- TWO-WIRE PATH
- ALL GROUND WIRE (GREEN) TO GROUNDING BUSS BAR
- CONCRETE PAD AS PER CONTROLLER ENCLOSURE MANUFACTURER'S SPECS. MINIMUM 6" THICK AND 6" BEYOND CABINET FACE. PROVIDE 0.5% SLOPE.
- FINISH GRADE
- #10 COPPER GROUND WIRE FROM ESP FIELD SATELLITE BUSS BAR TO GROUNDING GRID
- 3" PVC CONDUIT FOR CONTROL AND COMMON WIRES
- SPARE 2" CONDUIT EXTEND BEYOND 3'-0" BEYOND SLAB. SEAL END WITH GLUED CAP.
- PVC CONDUIT FOR TWO WIRE PATH
- 1" PVC CONDUIT FOR 120 VAC POWER SUPPLY

	CITY OF TEMPE / PUBLIC WORKS DEPARTMENT	NOT TO SCALE
	<h2 style="margin: 0;">IRRIGATION SATELLITE EXTERIOR INSTALLATION</h2>	
APPROVED: 		7/21/11 DATE
DEPUTY PUBLIC WORKS DIRECTOR / CITY ENGINEER		REVISED JULY 2011

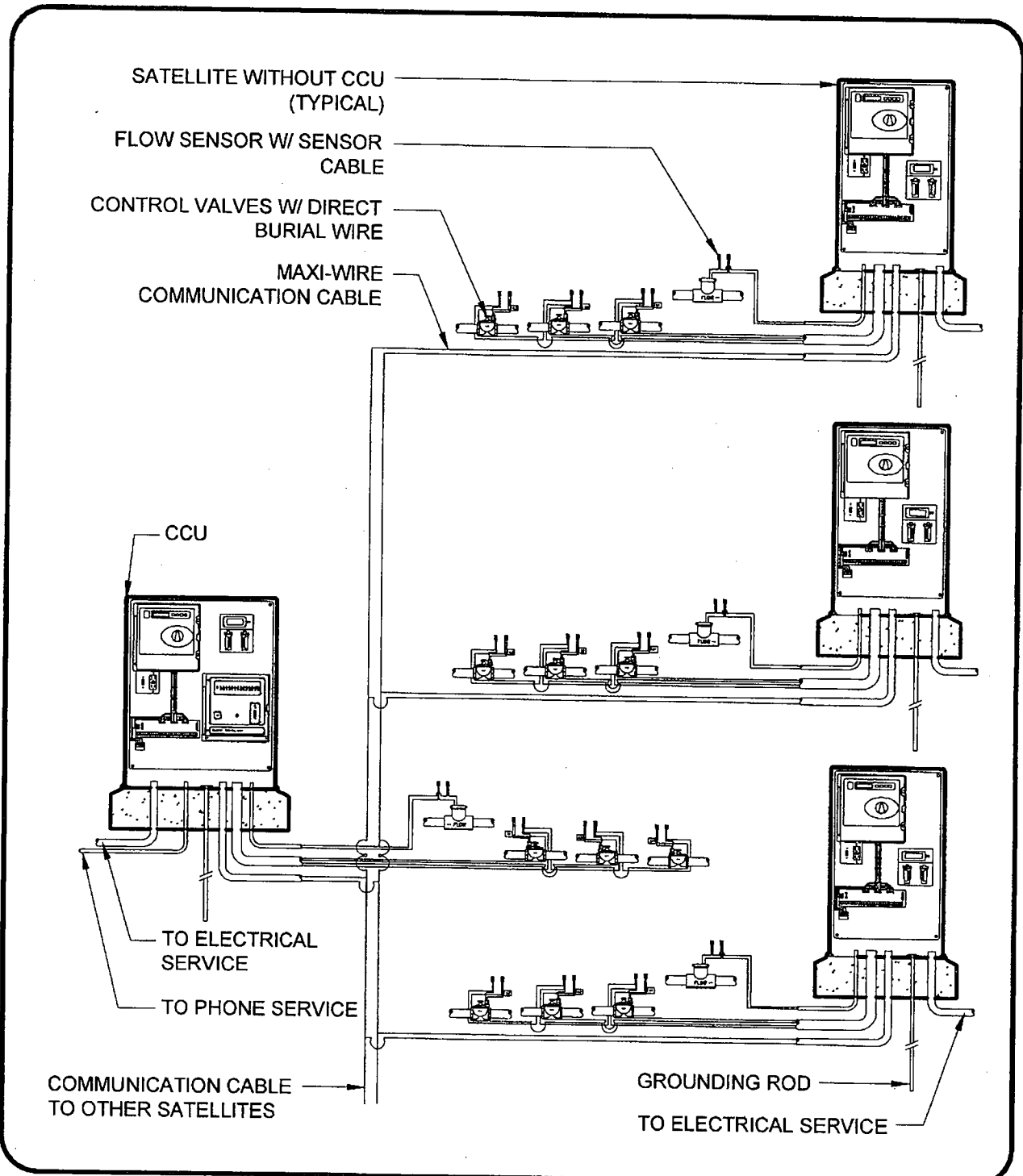

	CITY OF TEMPE / PUBLIC WORKS DEPARTMENT	NOT TO SCALE
	<h2 style="margin: 0;">IRRIGATION SATELLITE INTERIOR INSTALLATION</h2>	
	APPROVED: <u>Andy</u> <small>DEPUTY PUBLIC WORKS DIRECTOR / CITY ENGINEER</small>	DATE: <u>7/21/11</u>
		REVISED JULY 2011



	CITY OF TEMPE / PUBLIC WORKS DEPARTMENT	NOT TO SCALE
	<h2>MAXICOM SATELLITE SYSTEM SCHEMATIC</h2>	
	APPROVED: <u><i>Aneby</i></u> <small>DEPUTY PUBLIC WORKS DIRECTOR / CITY ENGINEER</small>	DATE: <u>7/21/11</u>

REVISED JULY 2011

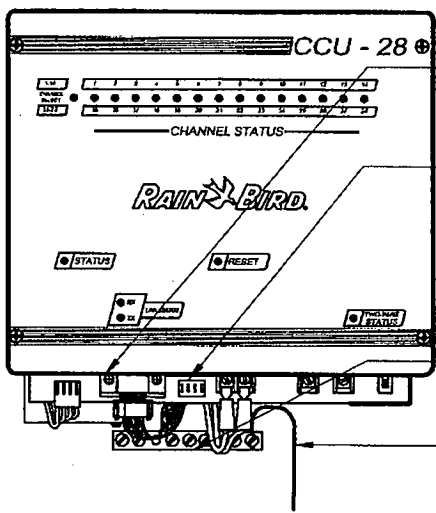

- 9 PIN CABLE CONNECTION TO RAIN BIRD RADIO MODEM KIT (RMK) NOT SHOWN
- S4 CCU ID LINK SWITCH (SET BY DISTRIBUTOR)
- CCU GROUNDING BUSS BAR
- #10 COPPER GROUND WIRE FROM CCU GROUNDING BUSS BAR TO GROUNDING GRID (SEE GROUNDING GRID MAXICOM DETAIL 305)

NOTE:
USE EITHER 9 PIN OR 25 PIN
CABLE CONNECTION.

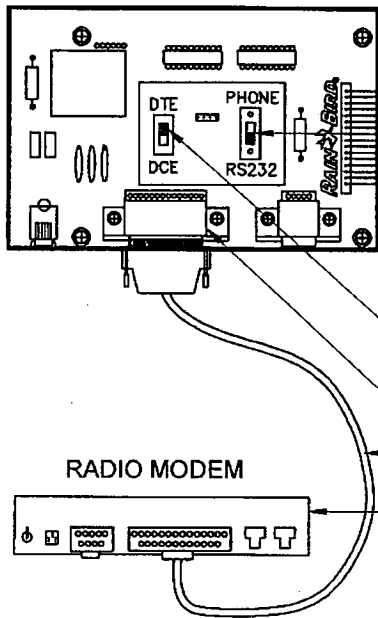

- INTERFACE BOARD
- SET SWITCH TO RS232
- SET SWITCH TO DTE
- 25 PIN CONNECTOR (USE RS232 CABLE)
- RS232 SERIAL CABLE (TO MODEM)
- RADIO MODEM (RADIO, POWER SUPPLY, ANTENNA AND CABLE ALSO REQUIRED)

REVERSE DETAIL

	CITY OF TEMPE / PUBLIC WORKS DEPARTMENT	NOT TO SCALE
	<h2 style="margin: 0;">MAXILINK RADIO COMMUNICATION WIRING DIAGRAM</h2>	
	APPROVED: <u><i>Analy</i></u> <small>DEPUTY PUBLIC WORKS DIRECTOR / CITY ENGINEER</small>	DATE: <u>7/21/11</u>
		<small>REVISED JULY 2011</small>

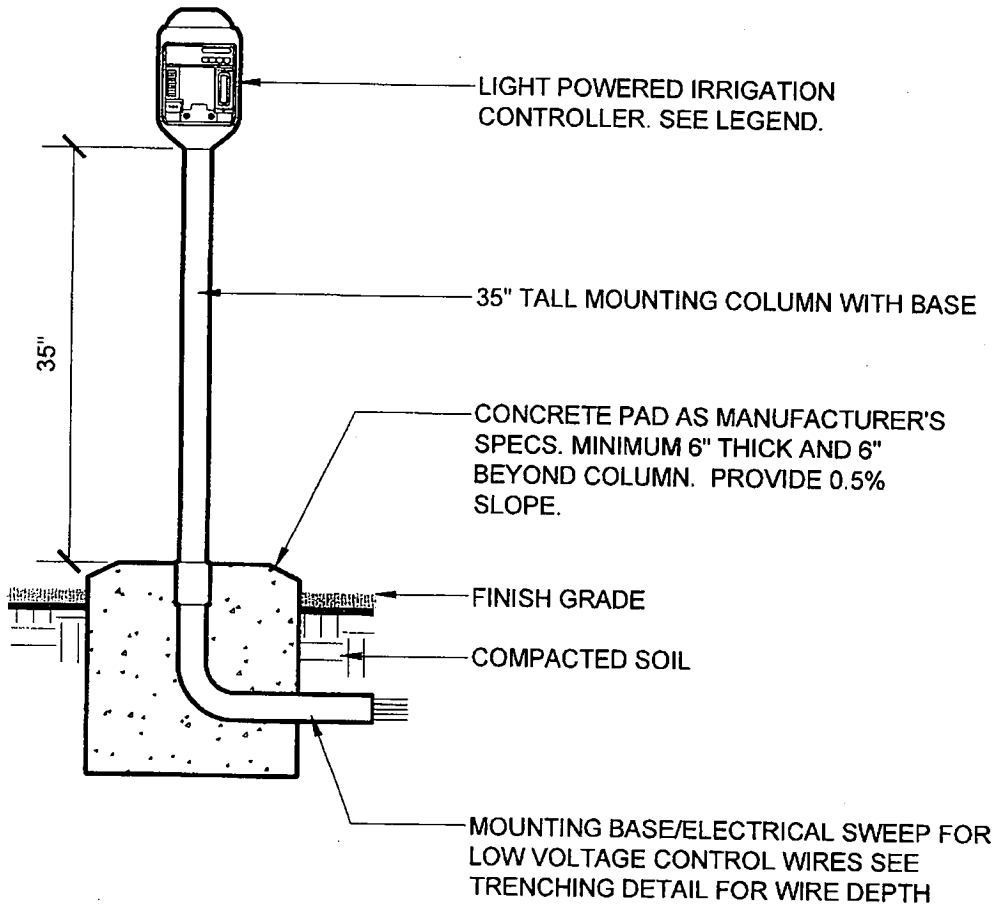

CITY OF TEMPE / PUBLIC WORKS DEPARTMENT

NOT TO SCALE

LIGHT POWERED CONTROLLER

T-750

APPROVED:

Andy

7/21/11

DEPUTY PUBLIC WORKS DIRECTOR / CITY ENGINEER

DATE

REVISED JULY 2011

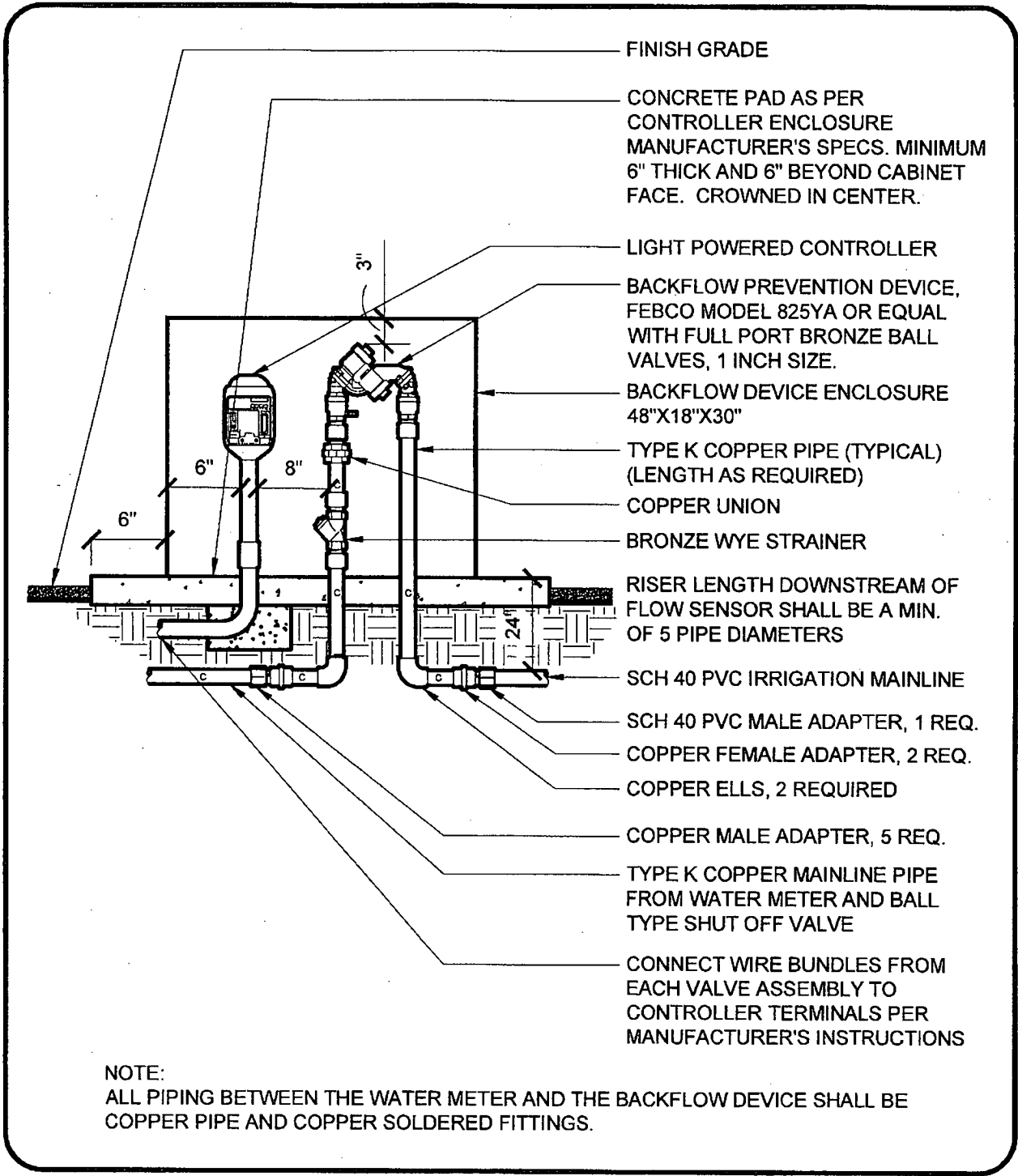

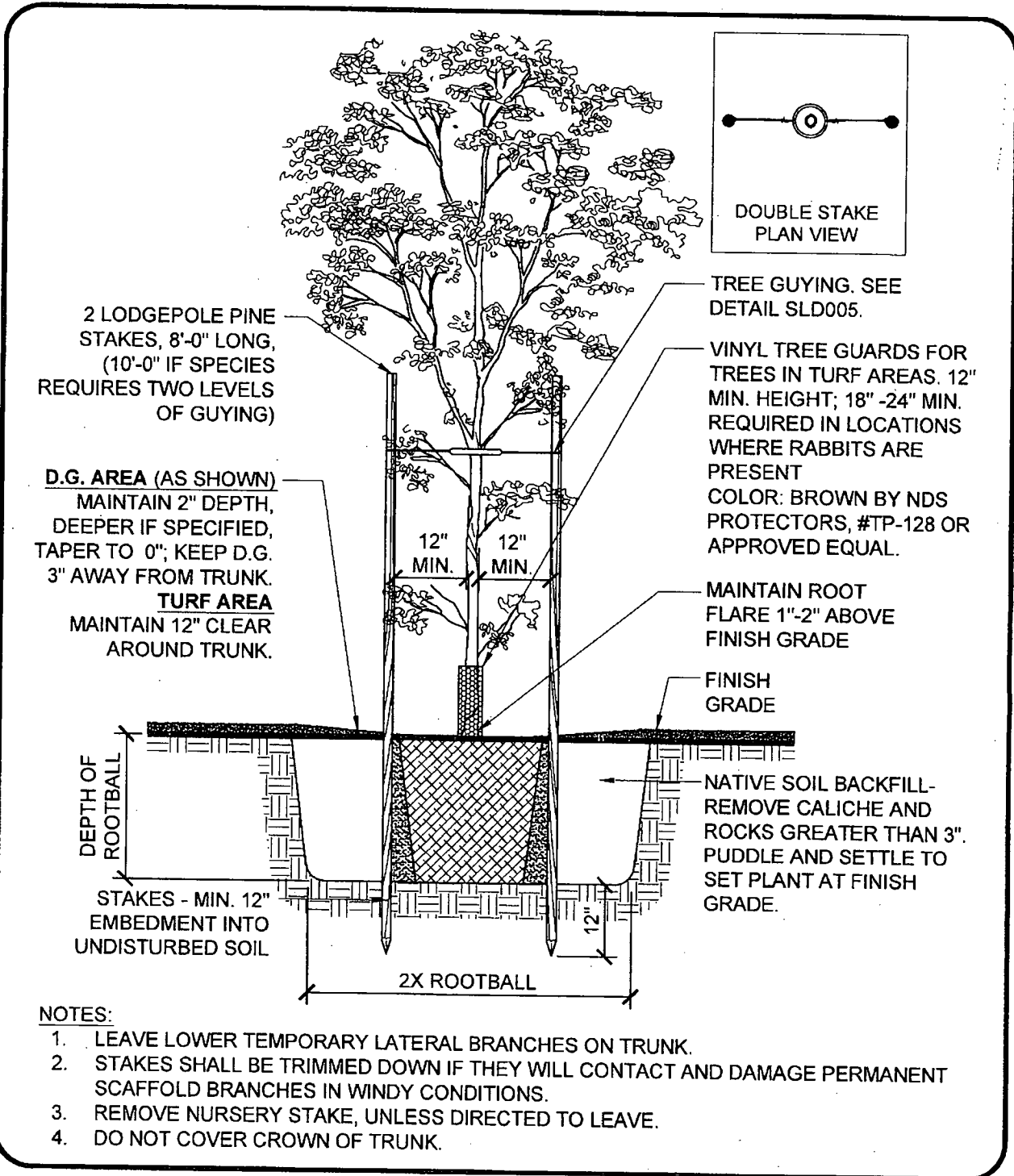

	CITY OF TEMPE / PUBLIC WORKS DEPARTMENT	NOT TO SCALE
	<h2>BACKFLOW PREVENTOR WITH SOLATROL CONTROLLER</h2>	
	APPROVED: <u>Andy</u> <small>DEPUTY PUBLIC WORKS DIRECTOR / CITY ENGINEER</small>	<u>7/21/11</u> <small>DATE</small>

REVISED JULY 2011

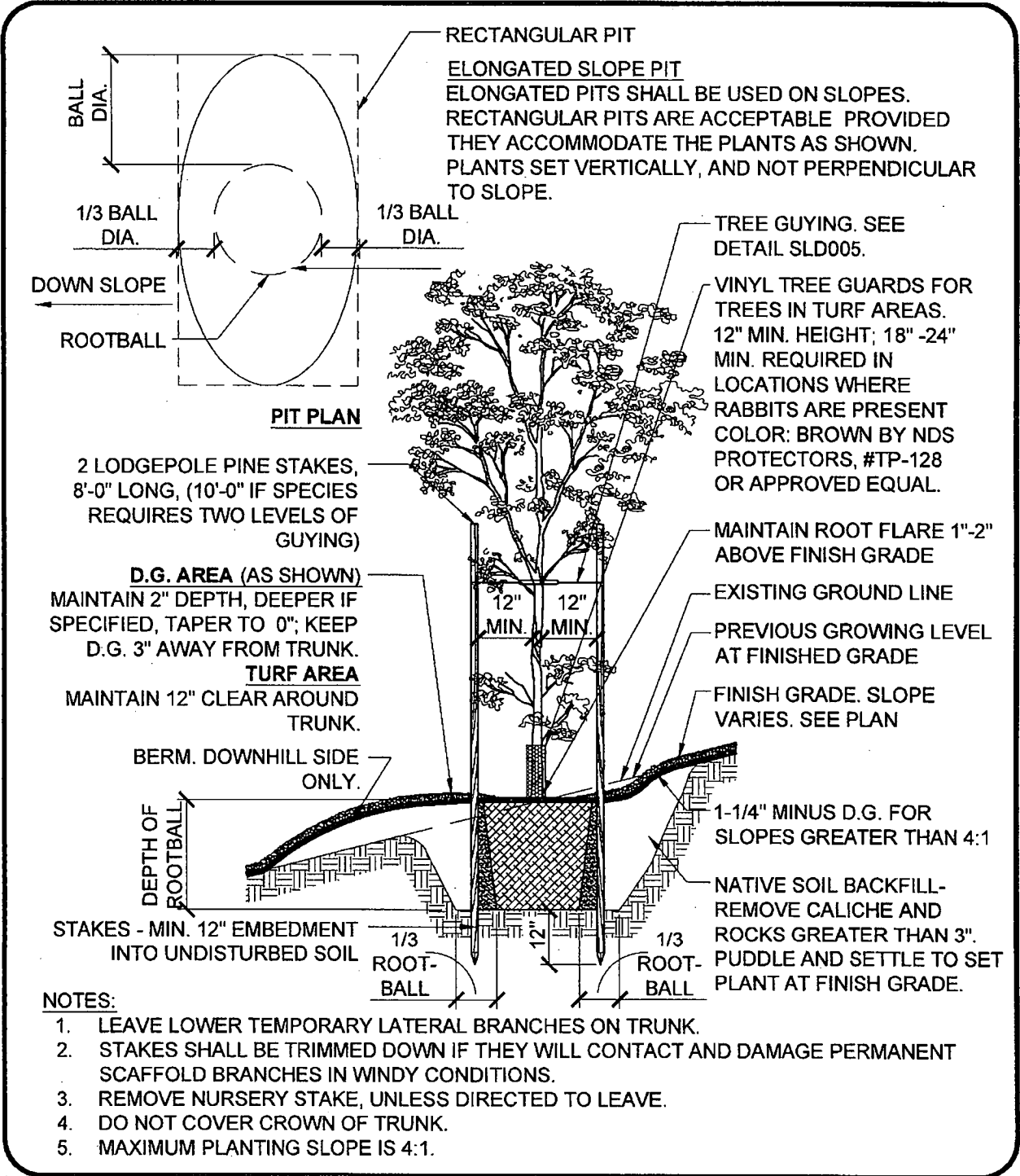

	CITY OF TEMPE / PUBLIC WORKS DEPARTMENT	NOT TO SCALE
	DOUBLE STAKE TREE 5 GAL., 15 GAL., 24" BOX	
	APPROVED: <i>Andy</i> <small>DEPUTY PUBLIC WORKS DIRECTOR / CITY ENGINEER</small>	7/21/14 <small>DATE</small>



	CITY OF TEMPE / PUBLIC WORKS DEPARTMENT	NOT TO SCALE
	DOUBLE STAKE TREE ON SLOPE 5 GAL., 15 GAL., 24" BOX	
	APPROVED: <u>Andy</u> <small>DEPUTY PUBLIC WORKS DIRECTOR/CITY ENGINEER</small>	DATE: <u>7/21/14</u>

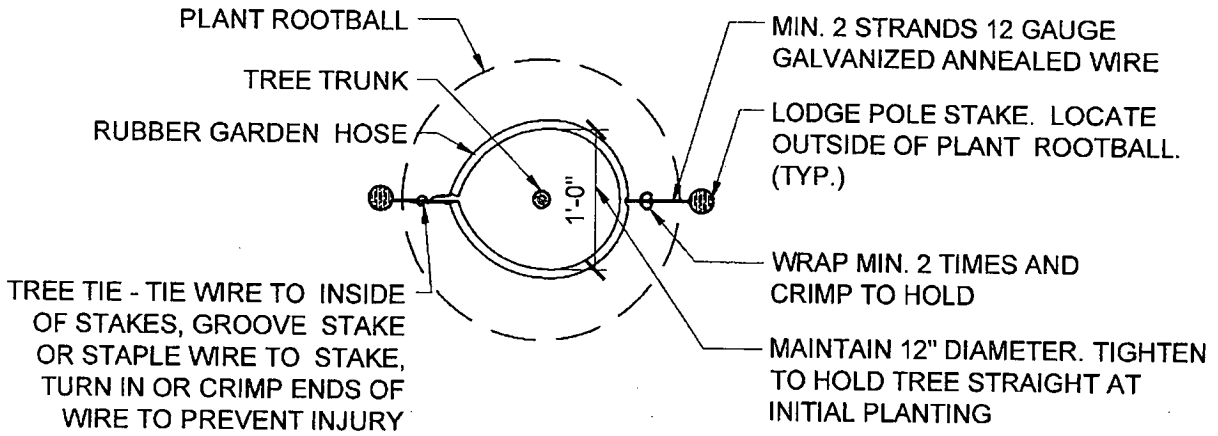

TREE STAKING PLAN - DOUBLE

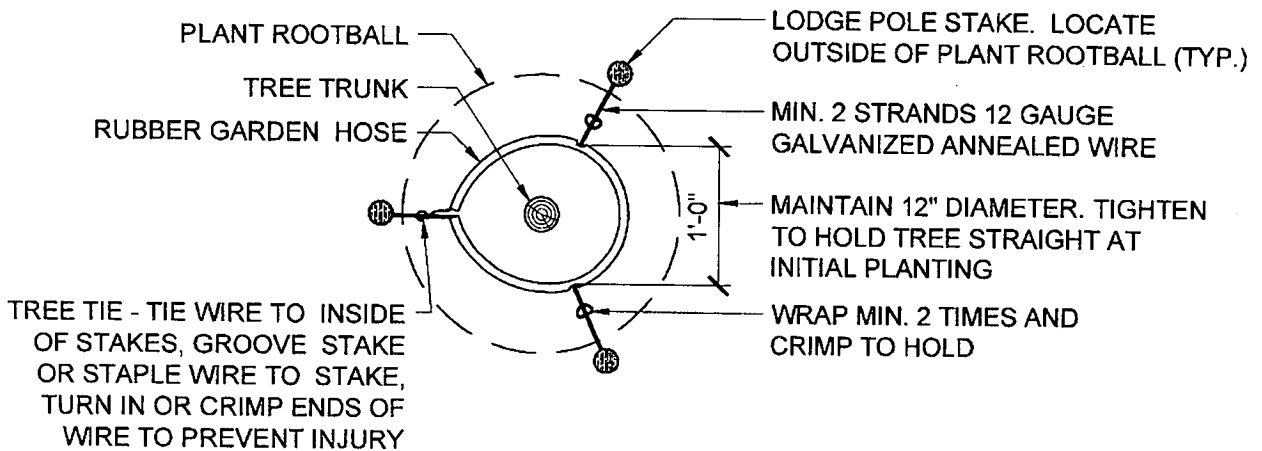

TREE STAKING PLAN - TRIPLE

	CITY OF TEMPE / PUBLIC WORKS DEPARTMENT	NOT TO SCALE
	TREE STAKING AND GUYING (SINGLE TRUNK)	
	APPROVED: <u>Andy</u> <small>DEPUTY PUBLIC WORKS DIRECTOR / CITY ENGINEER</small>	<u>7/21/11</u> <small>DATE</small>

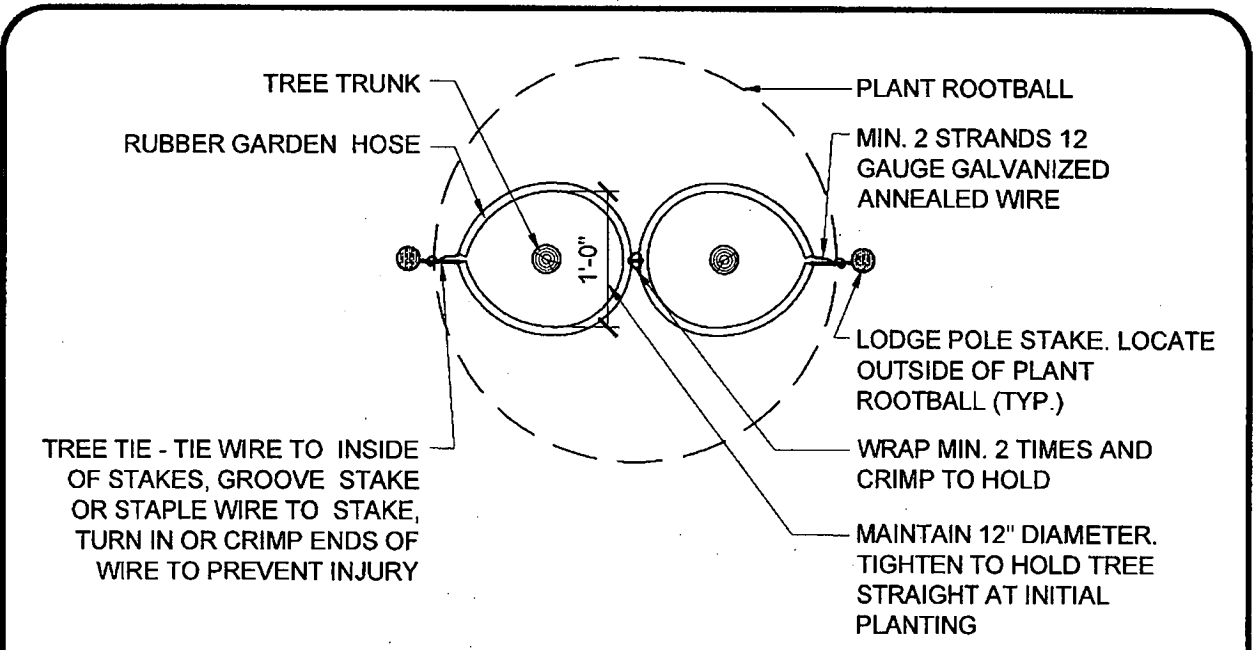

TREE STAKING PLAN - DOUBLE

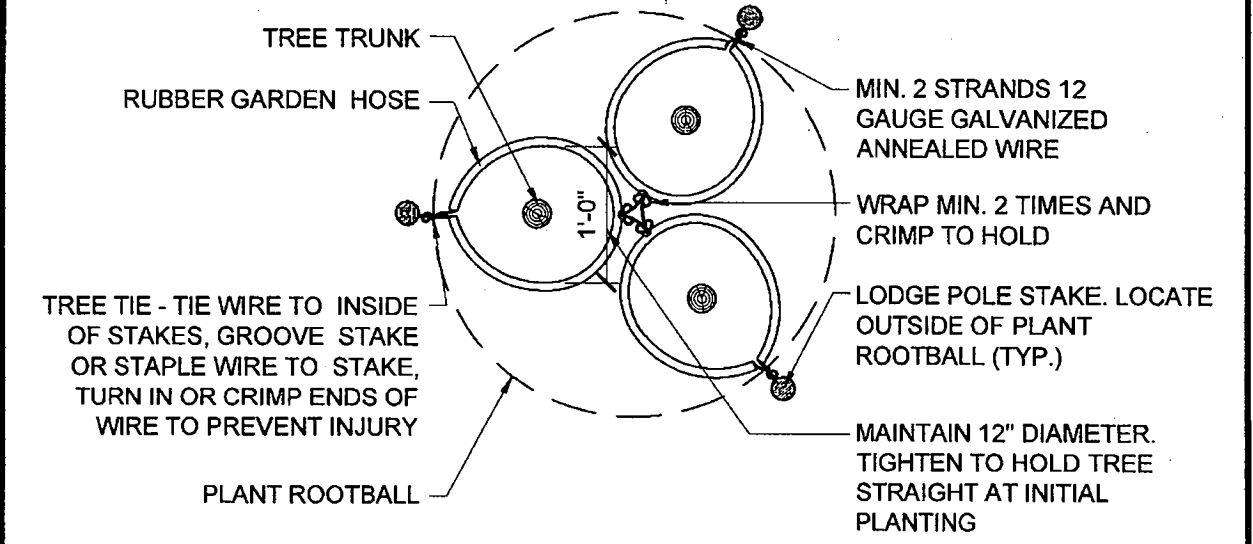

TREE STAKING PLAN - TRIPLE

	CITY OF TEMPE / PUBLIC WORKS DEPARTMENT	NOT TO SCALE
	TREE STAKING AND GUYING (MULTIPLE TRUNK)	
	APPROVED: <u>Andy</u> <small>DEPUTY PUBLIC WORKS DIRECTOR/CITY ENGINEER</small>	<u>7/21/11</u> <small>DATE</small>

NOTES:

1. TOP OF ROOT CONTROL BARRIER MUST BE 2" ABOVE GRADE.
2. POSITION ROOT CONTROL BARRIER ADJACENT TO STRUCTURE.
3. RAISED ROOT DEFLECTORS MUST BE FACING PLANTED AREA.
4. BARRIER SHALL EXTEND A MIN. OF 18" BELOW BOTTOM OF HARDSCAPE.
5. PROVIDE A MIN. OF 12 FEET LENGTH OF ROOT BARRIER PER TREE.
6. ROOT BARRIER SHALL BE A MIN. OF 18" BELOW GRADE NEXT TO ANY WALK OR SLAB.
7. ROOT BARRIER SHALL BE A MIN. OF 24" BELOW GRADE NEXT TO ANY CURB OR HEADER.

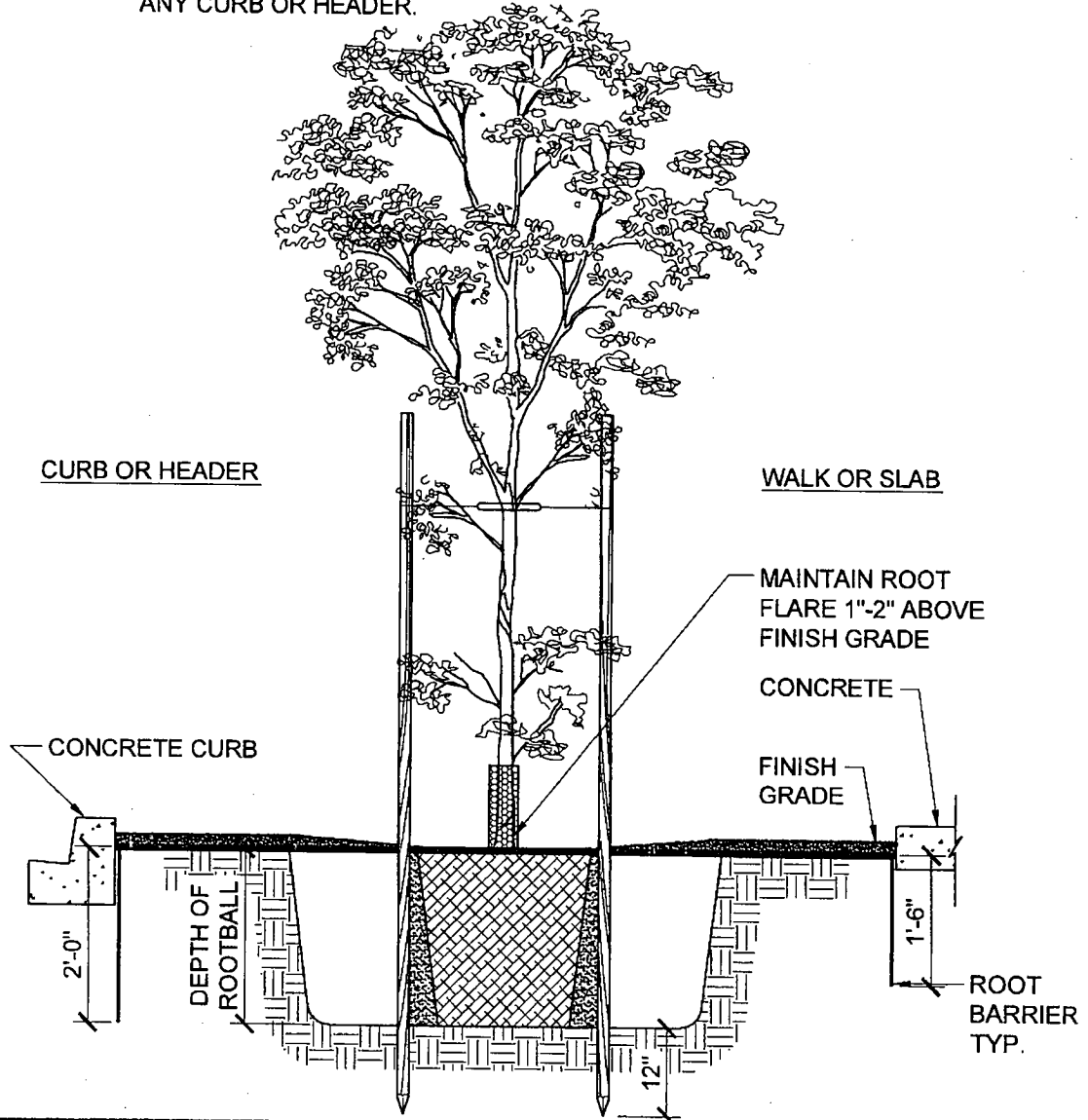

CITY OF TEMPE / PUBLIC WORKS DEPARTMENT

NOT TO SCALE

ROOT BARRIER

SLD007

APPROVED:

DEPUTY PUBLIC WORKS DIRECTOR / CITY ENGINEER

Andy

7/21/11

DATE

REVISED JULY 2011

DG AREA (AS SHOWN)
 MAINTAIN 2" DEPTH,
 DEEPER IF SPECIFIED,
 TAPER TO 0"; KEEP
 D.G. 3" AWAY FROM
 TRUNK.

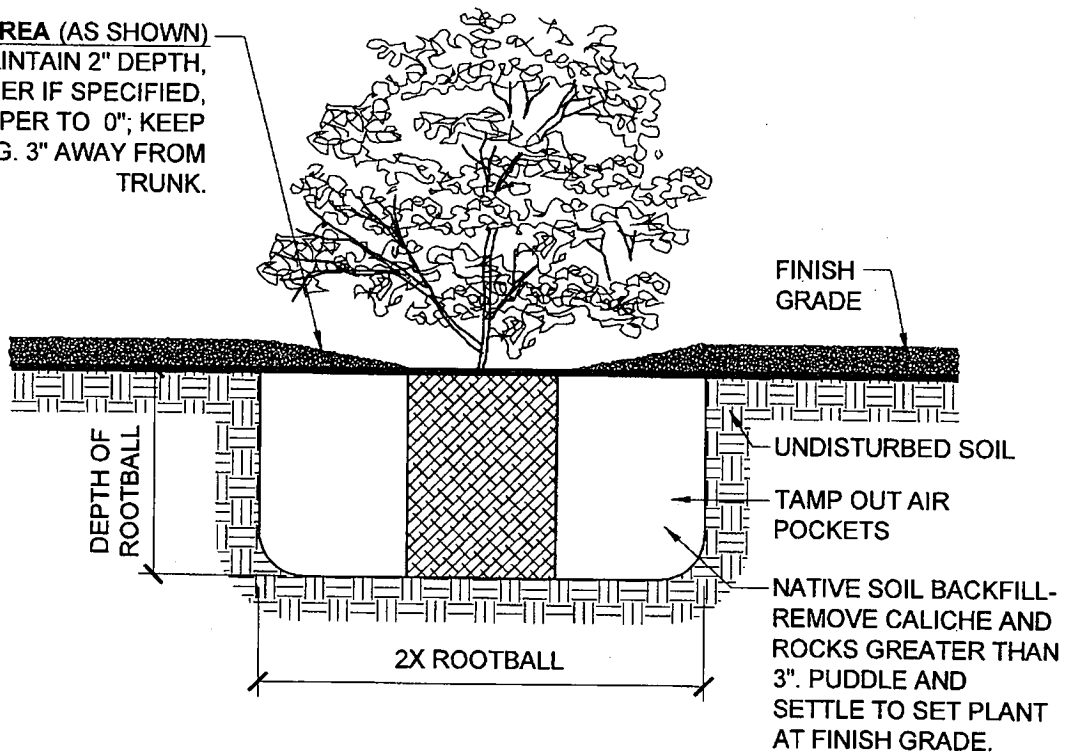

CITY OF TEMPE / PUBLIC WORKS DEPARTMENT

NOT TO SCALE

SHRUB PLANTING

SLD008

APPROVED: Andy
DEPUTY PUBLIC WORKS DIRECTOR / CITY ENGINEER

7/21/11
DATE

REVISED JULY 2011

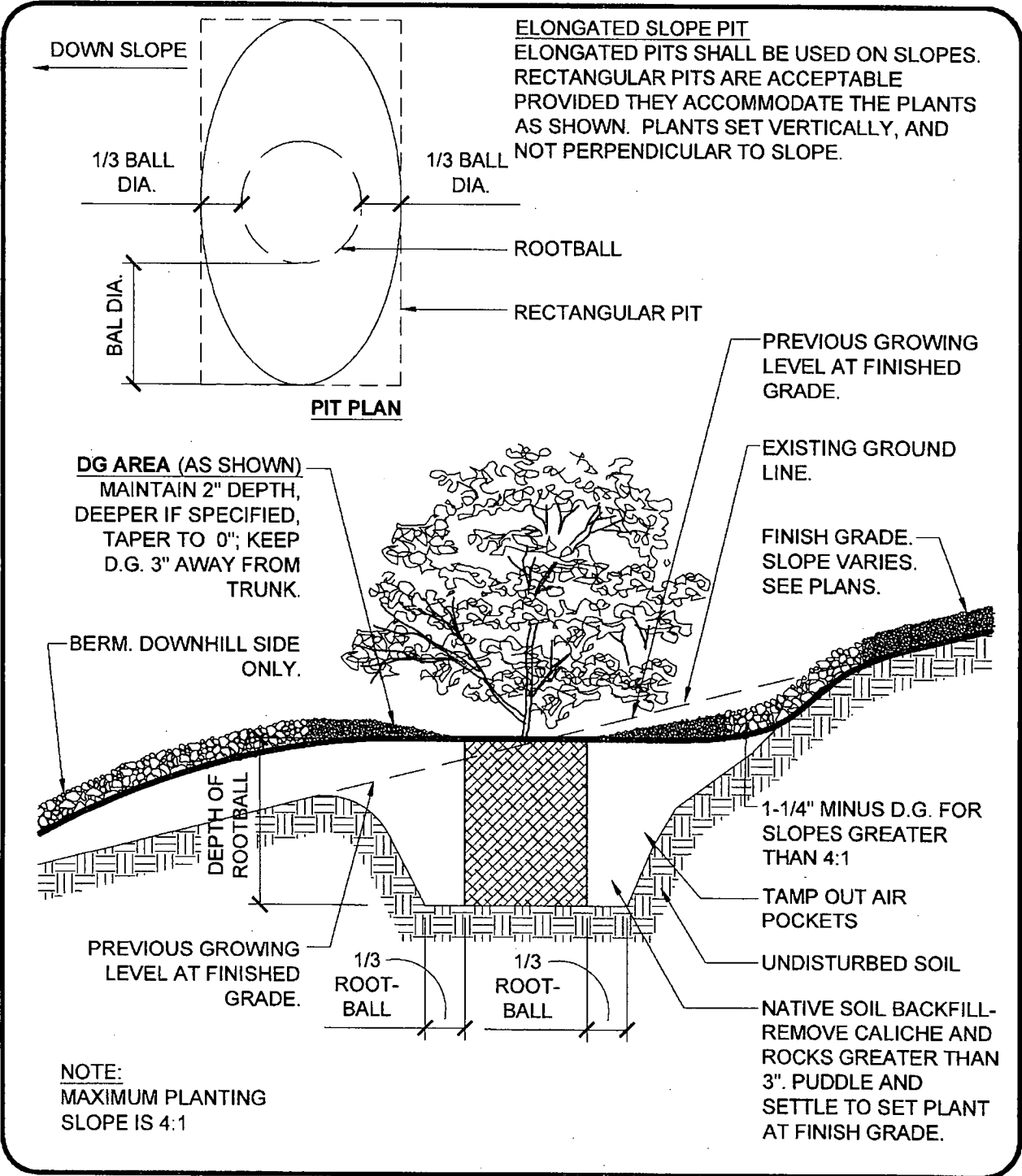

	CITY OF TEMPE / PUBLIC WORKS DEPARTMENT	NOT TO SCALE
	<h2>SHRUB PLANTING ON SLOPE</h2>	
	APPROVED: <u>Andy</u> <small>DEPUTY PUBLIC WORKS DIRECTOR/ CITY ENGINEER</small>	7/21/11 <small>DATE</small>

REVISED JULY 2011

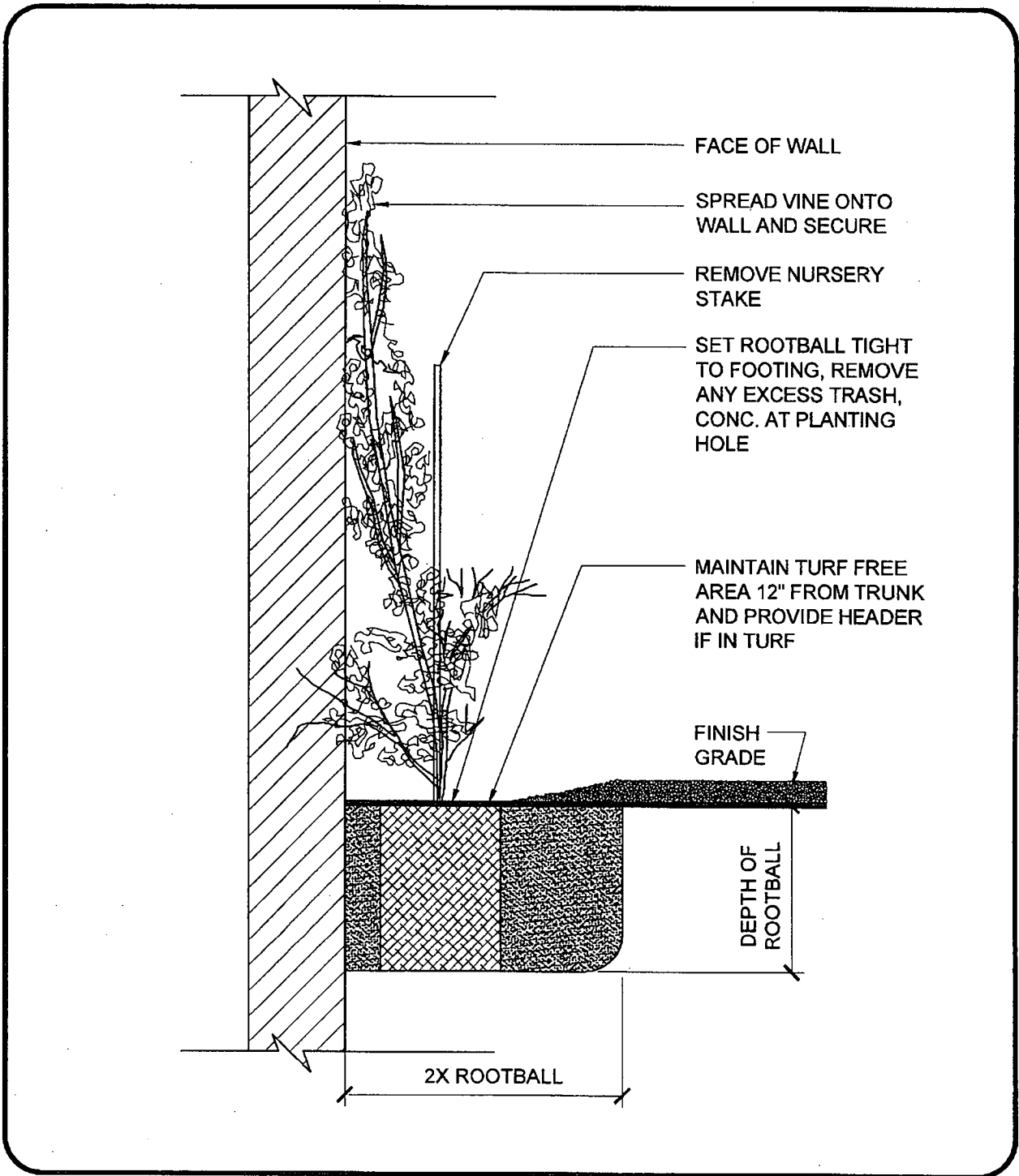

	CITY OF TEMPE / PUBLIC WORKS DEPARTMENT	NOT TO SCALE
	VINE PLANTING	
	APPROVED: <u>Andge</u> <small>DEPUTY PUBLIC WORKS DIRECTOR / CITY ENGINEER</small>	<u>7/21/11</u> <small>DATE</small>

NOTE:
 LOCATE PLANTS SPACED EQUIDISTANT (D) FROM EACH
 OTHER AS SHOWN. D = AS SHOWN ON PLANTING PLAN.

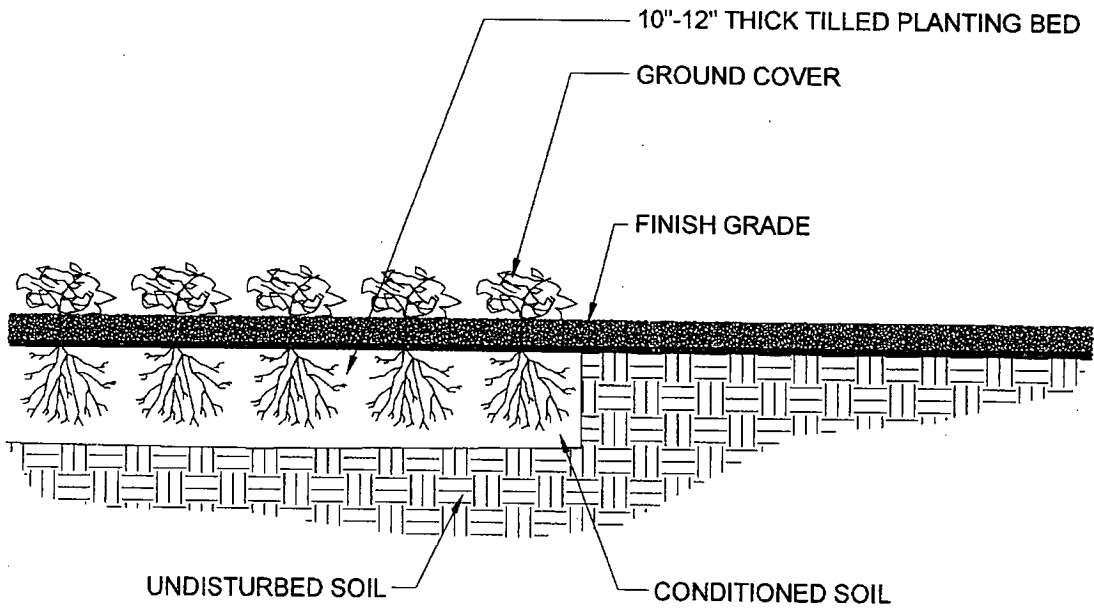
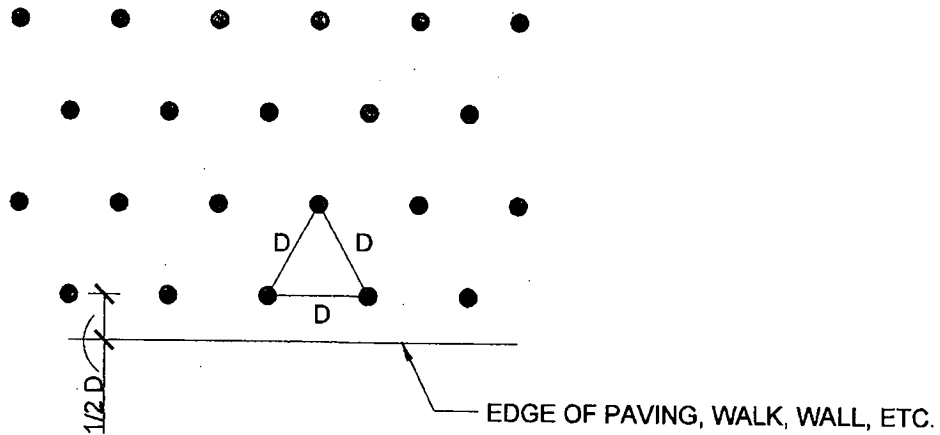

CITY OF TEMPE / PUBLIC WORKS DEPARTMENT

NOT TO SCALE

GROUNDCOVER PLANTING

SLD011

APPROVED: Andy 7/21/11
DEPUTY PUBLIC WORKS DIRECTOR / CITY ENGINEER DATE

REVISED JULY 2011

NOTES:

1. SEE PLANT LEGEND FOR SIZE AND COLOR OF DECOMPOSED GRANITE.
2. PRE-EMERGENT SHALL BE APPLIED TO FINISH SUB-GRADE BEFORE INSTALLATION OF DECOMPOSED GRANITE AND TO TOP OF DECOMPOSED GRANITE AFTER INSTALLATION.
3. FOR SLOPES GREATER THAN 4:1, USE 1-1/4" MINUS D.G.

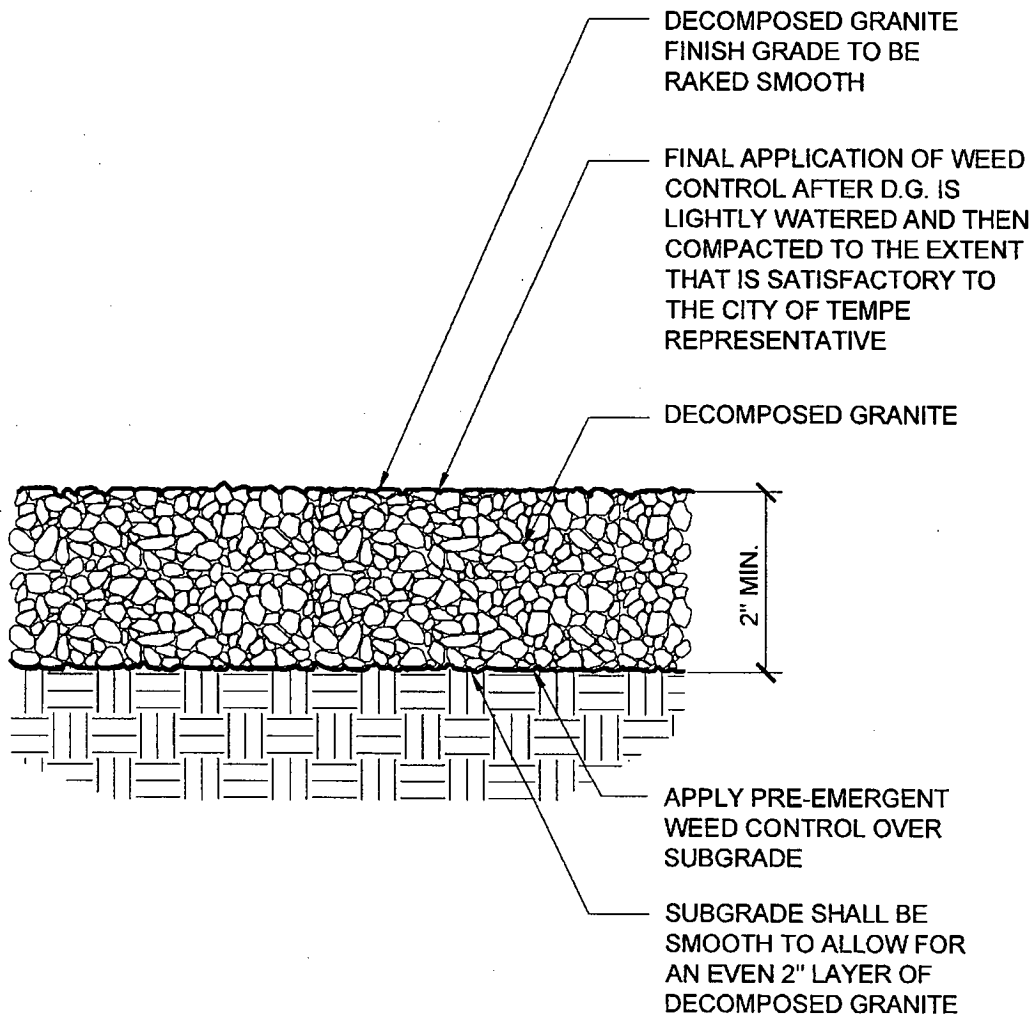

CITY OF TEMPE / PUBLIC WORKS DEPARTMENT

NOT TO SCALE

DECOMPOSED GRANITE

SLD012

APPROVED: _____

DEPUTY PUBLIC WORKS DIRECTOR / CITY ENGINEER

Anders

7/21/11

DATE

REVISED JULY 2011

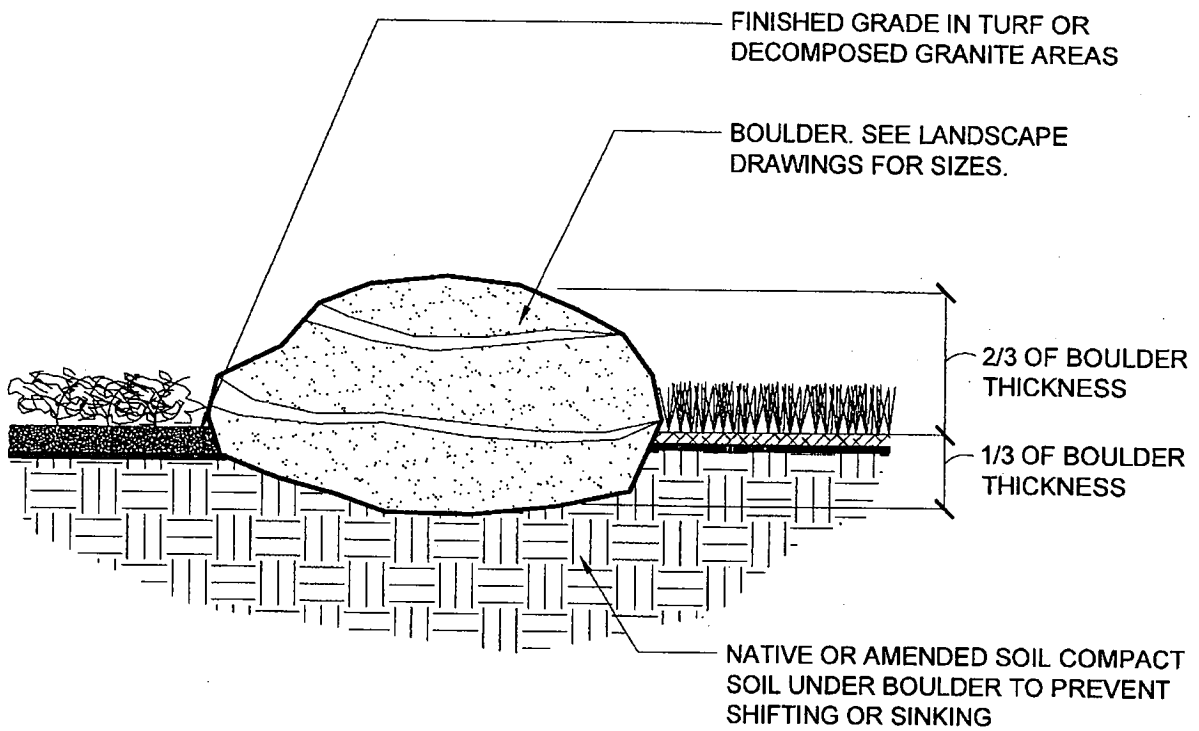

NOTES:

1. BOULDER SIZE AND TYPE SHALL BE VERIFIED WITH CITY OF TEMPE REPRESENTATIVE PRIOR TO PURCHASE.
2. BOULDER LOCATIONS AND FACE SHALL BE VERIFIED WITH CITY OF TEMPE REPRESENTATIVE PRIOR TO PLACEMENT.



CITY OF TEMPE / PUBLIC WORKS DEPARTMENT

NOT TO SCALE

BOULDER INSTALLATION

SLD013

APPROVED: _____

Andye

DEPUTY PUBLIC WORKS DIRECTOR / CITY ENGINEER

7/21/11

DATE

REVISED JULY 2011

