



## MEMORANDUM

To: Historic Preservation Commission  
From: Zachary J. Lechner, Historic Preservation Officer (ext. 8870)  
Date: July 3, 2024  
Subject: Agenda Item #6: Presentation on City pilot program installing arm rests in Old Mill Avenue Bridge alcoves

---

City staff members Jessica Wright, Human Services Manager—Homeless Solutions, and Kip Carroll, Transportation Maintenance Manager, will provide an update on the pilot program to install metal removable arm rests in two of the eight alcoves of the Old Mill Avenue (Tempe) Bridge, a Tempe Historic Property Register-designated and National Register of Historic Places-listed structure.

At the July 13, 2022, HPC meeting, City staff, on behalf of the Homeless Solutions Task Force, requested a Certificate of Appropriateness to install permanent gates across the opening of each alcove. Commission members expressed serious reservations with this plan, citing concerns about limiting legitimate use of and damaging the concrete alcoves. The HPC motioned for a continuance of the item, directing staff to devise a different plan and to present it at a later Commission meeting.

Staff returned to present at the July 12, 2023, HPC meeting, this time proposing to install removable metal arm rests in each alcove. Staff showed Commissioners a prototype and noted that the design would prevent individuals from lying across the bench inside of the alcoves and that the arm rests would not damage the alcoves. HPC members were very receptive to staff's proposal and requested that staff return within six months to allow them time to test the effectiveness of installing arm rests in two of the bridge's alcoves.

On January 26, 2024, in response to a query from the Historic Preservation Officer, Transportation Division staff stated that unforeseen delays had prevented the installation of one of the arm rests until November 2023. To allow more time for the trial, the Historic Preservation Officer made arrangements for staff to return to the Commission for an update in mid-2024.

No formal HPC action is required on this current agenda item. The Commission may simply provide feedback to staff or choose to pass a resolution in support of installing arm rests in the remaining six Old Mill Avenue Bridge alcoves.

### **ATTACHMENTS:**

1. July 13, 2022, HPC meeting minutes (alcoves item discussion highlighted)
2. July 12, 2023, HPC meeting minutes (alcoves item discussion highlighted)
3. Photos of arm rests in alcoves
4. Arm rest design drawing

# MINUTES

## HISTORIC PRESERVATION COMMISSION

### July 13, 2022

Minutes of the regular hearing of the Historic Preservation commission, of the City of Tempe, which was held in hybrid format in person at City Council Chambers, 31 East 5th Street, Tempe, AZ, and virtually through WebEx.

#### Regular Meeting 6:02 PM

##### **Present:**

##### **Staff:**

Kyle Woodson	Jeff Tamulevich, Director - Planning
Dave Fackler	Steve Abrahamson, Principal Planner
Chris Garraty	Zachary Lechner, Historic Preservation Officer
Elizabeth Gilbert	Joanna Barry, Administrative Assistant II, Com Dev
Laurene Montero	
Kiyomi Kurooka	
Reylynne Williams	
Gregory Larson	
Brenda Abney, ex officio member	

- 1) **Call to Audience:** Persons wishing to address the Commission on any matter may do so at the discretion of the Chair. However, Arizona Open Meeting Law limits Commission discussion to matters listed on the posted agenda. Other topics may be placed on a future agenda for discussion.

No members of the public were present.

- 2) **Voting of the Meeting Minutes**

Commissioner Williams noted that on page 2, at the top of the motion, there is double wording: "to approve the approved." Chair Woodson noted that on page 3, 6 lines down, in the sentence starting with "Woodson noted the criterion 'deed,'" it should just be the letter "D."

**Motion** by Vice Chair Fackler to approve the amended Meeting Minutes of June 8, 2022; second by Commissioner Larson. Motion passed on **8-0** vote.

**Ayes:** Kyle Woodson, Dave Fackler, Chris Garraty, Elizabeth Gilbert, Kiyomi Kurooka, Laurene Montero, Reylynne Williams, and Gregory Larson

**Nays:** None

**Abstain:** None

**Absent:** Jim Garrison

- 3) **Approval of Agenda**

Chair Woodson asked if any Commissioner would like to change the order of the agenda.

**Motion** by Vice Chair Fackler to approve the July 13, 2022, agenda; second by Commissioner Larson. Motion passed on **8-0** vote.

**Ayes:** Kyle Woodson, Dave Fackler, Chris Garraty, Elizabeth Gilbert, Kiyomi Kurooka, Gregory Larson, Laurene Montero, and Reylynne Williams

**Nays:** None

**Abstain:** None

**Absent:** Jim Garrison

**4) Request for a Certificate of Appropriateness for the installation of gates across the alcoves on the Tempe (Old Mill Avenue) Bridge, located at 1 South Mill Avenue (PL220179/HPO220006). The applicant is the Tempe Homeless Solutions Task Force.**

Presentation by Paul Bentley, Human Services Director, Isaac Chavira, Transportation Maintenance Manager, and Commander Kim Hale from the Tempe Police Department.

The Tempe Homeless Solutions Task Force was asked to seek options to address the trash, graffiti, and needs resulting from the presence of the unhoused in the alcoves on the Tempe Bridge. Maintenance of these areas is very staff intensive. Power washing may eventually damage the bridge materials. The Homeless Solutions Task Force seeks a Certificate of Appropriateness to install gates across the pedestrian rest bays as a permanent solution. Intention is to provide some type of barrier to prevent individuals from vandalizing and entering the areas and to provide for safety and health. Cost is approximately \$28,000. Funds have been identified. Gates could be installed by the end of the year, pending approval.

Commissioner Montero asked how long the issue has been going with people experiencing homelessness to the extent that is being stated in the presentation.

Mr. Bentley stated that the issue has been with us for a very long time. Increasing year to year. He said Tempe has on average 390-400 people on any given day experiencing homelessness. 35% increase from last year in Maricopa County.

Commissioner Montero asked for a plan on the gates. Will they be able to be open during the day? Will they be closed at night? Open during the day?

Mr. Bentley stated there are no specifics on exactly what time the gates will open. (Example open at 5 am, close at 6 pm.) Will look for input on what time gates should be open.

Commissioner Larson asked about the locking mechanism when the gates are closed. Is it going to be a padlock or deadbolt?

Mr. Chavira stated the City of Tempe uses a standard lock that most transportation and park employees can open.

Commissioner Larson asked, if the gate is open, is there a way to lock it open?

Mr. Chavira stated that with their current standard practices, if a gate is open it must be locked in an open position and if closed it will be locked in a closed position.

Commissioner Kurooka stated that some locations have played classical music to keep people from hanging out. Have you considered doing something like that?

Commander Hale stated there have been times they have used classical music on Mill Ave to discourage people from different activities. It has not been as effective as they would like it to be. The bridge is not wired for sound at this time.

Commissioner Kurooka asked about the higher lighting level. Will that not work either?

Commander Hale stated they have brought out portable light towers to Mill Ave. It has not been effective.

Commissioner Kurooka also brought up the possibility of using something with less visual impact than the gates (example: tempered glass or transparent material).

Mr. Bentley stated he will welcome all forms of input on other types of material to use instead of the gates. Vice Chair Fackler stated he has an issue with the damage the gates could cause to the structure. He said he does not want people driving down the bridge looking at the gates. What is most concerning is the attachments. Could someone climb over the gate? He would like to see additional options studied. Would the gates swing out? Sidewalk is only 3 feet wide.

Mr. Chavira stated that they will use 3-inch anchors. 3/8-inch diameter into the structure. The gates will be designed to be secure, and the gates will open completely and can be locked in position.

[Vice Chair Fackler's comment was inaudible]

Mr. Chavira stated they will identify an expertise in concrete. Possibly another alternative would be to use the sidewalk and not the alcove.

Chair Woodson asked if it's feasible to get a gate in there with no gap at the top that allows someone to climb over it.

Mr. Chavira stated that the gate will be high enough that it will prevent someone from jumping over.

Chair Woodson asked how many alcoves are there? Are they all on the southbound lanes? Are there issues with all the alcoves?

Mr. Chavira stated that there are 8 alcoves, and they are all located on the southbound lanes. All bridges in the city are maintained on a quarterly basis. Over the last 6 months cleaning has taken place on a weekly basis on Saturday. Cleaning trash daily. All 8 have had to be monitored for trash, graffiti and/or encampments. Graffiti is being address in all alcoves. Some graffiti can be removed and some has to be painted over. Some items found in the alcoves have had to be removed by a vendor due to safety and hazard for City staff.

Chair Woodson asked how the problem with the alcoves is being tracked.

Mr. Bentley stated that in their area they receive input from the community and staff, as well as community complaints, resulting in enhanced outreach in the area.

Mr. Chavira stated that he has had to increase efforts to clean the areas. Used to be done on a quarterly basis, then monthly, and now daily. Their emergency vehicle patrols the alcoves daily to clean up trash.

Chair Woodson asked if this is the primary option to be used.

Mr. Bentley stated they are implementing many different options to help provide assistance. . . [inaudible]

Commissioner Montero stated that Commissioner Kurooka had some ideas with the lighting and music that would be much less intrusive on the bridge.

Chair Woodson asked Dr. Lechner to provide perspective on the issue.

Dr. Lechner stated that it is unclear what impact by drilling into a nearly 100-year-old structure would have. Installing gates would change the appearance of the bridge. Dr. Lechner understands the City's desire to have a permanent solution to the problem. There is always going to be a risk involved when suggesting something like this. Something to consider is the issue of will the gates ever be removed. Could the holes be patched? In the Historic Preservation Office, Dr. Lechner said, he periodically monitors the various historic buildings owned by the City. All the structures are havens for the unhoused population in Tempe. If there is a way to get around access barriers, the unhoused population will find it. As noted in the suggested conditions of approval, if the Commissioners want to approve the Certificate of Appropriateness, we want to make sure if the drilling does occur, and the gates are removed, the holes can be a patched and will not damage the integrity of the structure. If the Commissioners do not want to approve the plan as is, the Certificate of Appropriateness can be denied for

the specific gate design and the Homeless Solutions Task Force can go back to the drawing board and try to incorporate the feedback given tonight. A denial of this plan does not mean a denial of any plan. Dr. Lechner noted the suggested conditions of approval in his staff report.

Chair Woodson asked, if the gates were installed and actually worked, do you see a major change in costs? Will it make a difference? Someone will need to open and close the gates daily.

Mr. Chavira stated that with the gates, there will be less trash left behind and less graffiti in the alcoves. They will go back to the original schedule for the bridge cleaning on a quarterly or monthly basis. Efforts will be made elsewhere than the bridge.

Mr. Abrahamson stated that lighting should be looked into more. At least on a trial basis. Light can be a deterrent.

Mr. Chavira stated that if they added lighting to the existing structure, they will still need to find a way to attach it. Lighting systems can be damaged easily.

Commissioner Larson stated that he is balancing between the bridge being pressure washed daily versus the drilling that will take place when the gates are installed. Would like to request a return to the table with a more cost-benefit analysis plan to protecting the bridge.

Chair Woodson asked Commissioner Larson if he is suggesting to table with the additional request? Commissioner Larson stated yes. Chair Woodson asked for a motion to table with the additional request for a more detailed proposal to address the concerns brought up by Commissioners.

Mr. Bentley requested clarity on the Commissioners' additional requests. He wanted to know if the Commissioners were looking for additional information about the possible harm that the attachment might do to the historic structure.

Chair Woodson suggested possibly getting detailed information from a specialist that could give information on how the attachments will or will not cause damage to the structure.

Vice Chair Fackler stated that yes more clarity is needed on what the attachment can do to the structure. He suggested possibly using a prop to determine that the gate cannot be ripped off the wall. The attachments need to present themselves as a permanent option.

**Motion** by Commissioner Larson to table [continue] PL220179/HPO220006; second by Vice Chair Fackler. Motion passed on **8-0** vote.

**Ayes:** Kyle Woodson, Dave Fackler, Chris Garraty, Elizabeth Gilbert, Kiyomi Kurooka, Gregory Larson, Laurene Montero, and Reyllynne Williams.

**Nays:** None

**Abstain:** None

**Absent:** Jim Garrison

## 5) Update on recent graffiti remediation at the Hayden Flour Mill Complex

Dr. Lechner presented an update on graffiti remediation efforts at the Hayden Flour Mill Complex (including 1951 Silos). In 2021, the City contracted with Logan Simpson for graffiti removal measures. Historic Preservation Officer is satisfied with Logan Simpson and the graffiti cleaning. Two chemicals were used to remove the graffiti that were not damaging. HPO denied Logan Simpson's offer to apply Si-Coat, which deters the graffiti from staying on the building, due to its sheen.

Chair Woodson asked for some additional photography following the phase of work. Is this something that will be done periodically if there are reports of more graffiti?

Dr. Lechner stated he will ask Logan Simpson for additional photos. If Logan Simpson can get the photos to Dr. Lechner, he will pass them along to the Commissioners. Yes, the North and West side have already been tagged with more graffiti. Further remediation will be done on an as-needed basis.

Commissioner Garraty stated that Logan Simpson did not get as many post-treatment photos. The graffiti is going up faster than the photos could be taken.

Chair Woodson asked for the drone footage.

Commissioner Garraty said he will look for better individual shots from the drone images.

## 6) Chair / Staff Updates

Chair Woodson asked Dr. Lechner to introduce Ms. Brenda Abney.

Dr. Lechner introduced Ms. Abney. She is the Manager of the Tempe History Museum, which oversees some historic houses in Tempe. She is also *ex-officio* member of the HPC, per the Tempe Historic Preservation Code.

Dr. Lechner stated that last month, at its June 23<sup>rd</sup> meeting, City Council unanimously adopted the updated Historic Preservation Plan as well as the two inventories of historical resources that HPC recommended for approval at its May 2022 meeting.

## 7) Current Events/ Announcements / Future Agenda Items

### Member Announcements

### Staff Announcements

Vice Chair Fackler stated that the first meeting of Technical Advisory Group for the General Plan 2050 will be Tuesday 7/19/22. Meetings are twice a month: 1st and 3rd Tuesdays of the month. Meetings continue until October 2023.

Dr. Lechner stated that at the next HPC meeting in August, there will be 2 agenda items. 1st is the Butler Gray House at 1220 S. Mill Ave. City Council approved a 5-year conservation easement agreement and lot split for the back of the property. A Zoning Map amendment will also have to be approved by Council. HPC will determine whether to recommend approval. Main August HPC meeting agenda item is the neighborhood meeting to regarding Zoning Map amendment related to request to designate Guadalupe Cemetery in Tempe Historic Property Register.

**Motion** by Vice Chair Fackler to adjourn; second by Commissioner Montero. Motion passed on **8-0** vote.

**Ayes:** Kyle Woodson, Dave Fackler, Chris Garraty, Elizabeth Gilbert, Gregory Larson, Kiyomi Kurooka, Laurene Montero, and Reyllynne Williams

**Nays:** None

**Abstain:** None

**Absent:** Jim Garrison

Hearing adjourned at 7:36 pm.

Prepared by: Jennifer Daniels, Administrative Assistant

Reviewed by: Zachary Lechner, Historic Preservation Officer

# MINUTES

## HISTORIC PRESERVATION COMMISSION

### July 12, 2023

Minutes of the regular hearing of the Historic Preservation commission, of the City of Tempe, which was held in hybrid format in person at City Council Chambers, 31 East 5th Street, Tempe, AZ, and virtually through WebEx.

#### Regular Meeting 6:00 PM

#### **Present:**

#### **Staff:**

Kyle Woodson	Jeff Tamulevich, Community Development Director
Dave Fackler	Ryan Levesque, Comm. Development Deputy Director
Erin Davis	Zachary Lechner, Historic Preservation Officer
Reylynne Williams	Ambika Adhikari, Principal Planner, Com Dev
Jean Robinson	Jennifer Daniels, Administrative Assistant II, Com Dev
Greg Larson	
Kiyomi Kurooka	

- 1) **Call to Audience:** Persons wishing to address the Commission on any matter may do so at the discretion of the Chair. However, Arizona Open Meeting Law Limits Commission discussion to matters listed on the posted agenda. Other topics may be placed on a future agenda for discussion.

- 2) **Voting of the Meeting Minutes**

Commissioner Williams stated that on page 3, Item #6, 7<sup>th</sup> line, after “resources/TCP’s” there is a period before the sentence ends. On page 4, 3<sup>rd</sup> paragraph, 2<sup>nd</sup> to the last sentence, after “Chair Woodson asked,” it should read “HPTP”. On page 5, in the last paragraph, it should read “possibility” not “possibly”. On page 7, Item #9, 2<sup>nd</sup> sentence, the word should be “Affordable” not “Adorable”.

**Motion** by Commissioner Robinson to approve Meeting Minutes for April 19, 2023, with corrections: second by Vice Chair Fackler. Motion passed on **7-0** vote.

**Ayes:** Chair Woodson, Vice Chair Fackler, Commissioners Davis, Robinson, Williams, Larson, and Kurooka

**Nays:** None

**Abstain:** None

**Absent:** Commissioners Engnell and Montero

- 3) **Approval of Agenda**

Approval of Agenda by Chair Woodson.

- 4) Discussion of Wexford Development’s proposed redevelopment of site that includes the 1<sup>ST</sup> **CONGREGATIONAL CHURCH**, designated in the Tempe Historic Property Register, and the **HARRY WALKER HOUSE**, a Historic Eligible and National Register of Historic Places-listed property, located at and near 101 East Sixth Street. The presenter is Darin Sender of Sender Associates.

Applicant Ms. Darin Sender gave a presentation on the site proposed for redevelopment. The site is located at 101 East 6<sup>th</sup> Street. Wexford Development is proposing a mixed-use, high-rise luxury residential community within Tempe's Urban Core with 572 market-rate luxury residential units and 6,000 square feet of ground-level commercial space. The site includes the 1<sup>st</sup> Congregational Church and former House of Tricks building (Harry Walker House). The development proposes retail along 7<sup>th</sup> Street. The development would retain the sanctuary (building with steeple) of the 1<sup>st</sup> Congregational Church, although this structure would not be part of the project. The sanctuary would be transferred to the City. The City would then take ownership of the sanctuary and possibly lease the building as a restaurant or for some type of similar use. The Harry Walker House is listed in the National Register of Historic Places. The applicant is proposing to have the building moved to a city park. The location is yet to be determined. Consultants have been hired to estimate the cost of moving the house. The entitlements package was submitted to the City on June 12. The City is requiring a Planned Area Development (PAD) for the development standards and a Development Plan Review (DPR) for the site and landscape review. Mr. Mike Duffy from RSP Architects spoke about the design of the building. Mr. Duffy stated that they are trying to establish an elevated landscape character. One of the things that is important to the concept is to heavily landscape the ground floor for the pedestrian experience. They have taken care to break down the massing of the building due to its large size. The building appears as three structures and has a Z-shaped configuration. Different materials would be used throughout to differentiate the different volumes.

Chair Woodson asked Dr. Lechner to explain the historic buildings. Chair Woodson asked if this project moves forward, what role will the Commission play in the decision making? Dr. Lechner explained if the applicant proposed partial demolition of the sanctuary, because the building is a Tempe Historic Property Register-designated site, that request would have to be reviewed by the HPC. The Commission would then receive the request for approval of a demolition permit. Next, the Commission would determine whether to approve or deny the demolition permit. If denied, there would be an automatic 180-day stay of demolition placed on the issuance of the demolition permit. During that time, there would be an attempt by the HPC and HPO to try to work out some type of alternative to demolition. If no resolution could be met at the end of the 180 days, the permit would then be issued to the applicant. Chair Woodson stated that he did not hear anything about demolition at this time. Is that on the table, he asked? Ms. Sender stated that only the outbuildings will be demolished. Dr. Lechner stated that the other portions of the Church building are included as part of the Tempe Historic Property Register designation. Chair Woodson asked if the Harry Walker House was designated in the Tempe Historic Property Register. Dr. Lechner stated it is not. It is listed as Historic Eligible.

Dr. Lechner presented some concerns about the project from the Economic Development Department. Its representatives were unable to attend the meeting. Ms. Sender's memo on the project states that the developer will repair the sanctuary with complementary architecture. Economic Development would like to see more detail on this. Economic Development would expect the Commission to have several questions about the Church sanctuary preservation, as well as the impact of a high rise so close to a historic asset. Economic Development also requested some clarification on the planned setback between the sanctuary and the proposed new building. There is a tentative plan for the developer to move the Harry Walker House, but it is not confirmed at this time whether that is feasible. The applicant is estimating a cost of between \$250,000-\$350,000 to relocate the house. That is in alignment with independent research Dr. Lechner conducted a few months ago. Economic Development was curious if the applicant can provide any insight on additional planning work that has been done for the proposed relocation of the house. Economic Development is further concerned about the development's 15% allotment of 4-bedroom units. The Department's concern is that the 4-bedroom units might attract student renters. Mr. Chad Schleicher, Economic Development Program Manager, has been working on the possible adaptive reuse of the sanctuary as a restaurant. Economic Development would like to see if the applicant can provide more information on how such a deal might be worked out with the City. It is unknown at this time if City Council will support the GPLET that the developer is seeking for the project if the City does not receive more information on the preservation of the sanctuary, the adaptive reuse of the sanctuary, and the removal of the Walker House. Dr. Lechner stated that he concurs with the points Economic Development has made.

Chair Woodson asked Dr. Lechner to clarify if the sanctuary is part of the project. Ms. Sender stated that there may have been some confusion since the sanctuary was excluded from the entitlements. Ms. Sender stated that the developer does not intend to rezone or redevelop the sanctuary. The plan is to transfer the title of that property to the City.



Commissioner Robinson asked if the entire complex of House of Tricks is registered or just the building on the east. Is that the only building that would be moved if relocated? Ms. Sender stated, yes, the Harry Walker House is the only building that will be moved. The other building is not structurally sound and is not listed in any historic register. Commissioner Robinson asked which part of the Church is on the Tempe Historic Register? Dr. Lechner stated it is the entirety of the 1<sup>st</sup> Congregational Church site. This would require HPC approval for a request for a partial demolition of the other, non-sanctuary portions of the building. Commissioner Robinson asked why the sanctuary was not being demolished as well. What is the intent of preserving the sanctuary? Ms. Sender stated that it was a request of the City that her client chose to agree with. Commissioner Robinson asked if the City only requested that they not demolish the sanctuary. Ms. Sender stated that in order to have the project fit on the site and to include the number of units they require, they needed to encroach onto that Church property. Commissioner Robinson stated that she would contend there would be more significant buildings than the Church. She stated that she has a hard time with the new structure coming up within 10 feet of the sanctuary. With that kind of structure, it makes that side of the building invisible. It seems like an inappropriate gesture to construct such a tall building next to anything that small. In response to another question, Ms. Sender stated that she did file a demo permit application in 2021, which came to the HPC and was denied, triggering the 6-month waiting period. That earlier demo permit request was for the entire property, and the developer has chosen to revise the plan and preserve the sanctuary.

Commissioner Larson stated that he recalls that demo request was presented to the HPC and was denied, so the building remains intact. It sounds like one of the reasons the building may not have been demolished is due to a stipulation in the Historic Preservation Ordinance requiring the developer and the City to sit down and come up with an alternate arrangement whereby the developer avoids demolishing the historic structure. Commissioners Larson said it appears that we are seeing a rendering of an option not to demolish the building and an arrangement whereby that building will be preserved. From that standpoint, he stated, he is encouraged by this proposal of redevelopment. Commissioner Larson said that there may be things that are not desirable about the proposal; however, this is generally a good thing.

Mr. Ryan Levesque asked if he could elaborate on the prior submittal. At that time, the proposal involved just the property of the 1<sup>st</sup> Congregational Church, the property to the north, and the parking lot. At that time, the request was for total demolition of the building without a proposed development plan. There was an action by the Commission to deny the demolition permit. There were further negotiations at that time on alternatives. Some of those negotiations did include the possibility of a partial demolition of the Church building. Chair Woodson asked if it would be necessary to amend the 2021 demolition permit application. Mr. Levesque stated that another demolition permit application would need to be submitted instead, but it would have a modification to the building design. That item would have to be brought forward to the HPC. Then, additionally, because the current proposal includes the property along 7<sup>th</sup> Street, there is an obligation for a PAD process, on which the HPC would be asked to make a recommendation. There is also the potential for the HPC to recommend delisting a portion of the site so that the remaining historic designation is only applied to the remaining Church sanctuary and not the other portions of the Church parcel.

Ms. Sender asked if a Certificate of Appropriateness approval would also be needed from HPC. Mr. Levesque stated, yes, one related to the design.

Chair Woodson asked if the Commission will be seeing a demolition permit application again. Dr. Lechner stated yes. Chair Woodson asked if the 2021 permit can be rescinded since it will not be used. Mr. Levesque stated there is no active permit.

Commissioner Davis asked if there has been any thought to adaptive reuse for the Harry Walker House rather than moving the building. She said when you move a historic property, you automatically diminish its integrity by taking it from its original location. Mr. Duffy stated that they did study a few of the options and, unfortunately, given the location of the Walker House, preserving it in place would make a large portion of the project site undevelopable, and it did not seem appropriate to span a building up and over Walker House or bury it in between. Their team concluded it was not feasible. The sanctuary was a little easier to draw a boundary around. The Harry Walker House is in a more difficult location, given the site access constraints.

Vice Chair Fackler asked if the proposed placement of the amenity deck on the 7<sup>th</sup> floor being within a few feet of the top of the Church is by design or accident. Mr. Duffy stated that the amenity deck will be primarily facing southwest. He said they have respectfully tried to move activity away from the Church and Islamic Community Center side and concentrate activity along 7<sup>th</sup> Street. The heights ending up there was not by design. Vice Chair Fackler asked: What level is the crossover above the public alley? Mr. Duffy stated that the clearance height that they are maintaining is 15 feet to enable fire truck access. Vice Chair Fackler asked: When looking at the elevation of the building, with the Church in the foreground and the building in the background, what materials are we looking at? Mr. Duffy stated that the building materials leverage a combination of glass for the towers and residences. The garage screenings are a series of metal louvers that are shade fins. They are attached to the building and provide a decent amount of shading and screening. Mr. Duffy stated that they are trying to get the garage to as open as they can while also satisfying vehicle screening requirements and providing visual interest. Vice Chair Fackler asked about the plants being shown draping off various levels of the building. Are they real plants? Mr. Duffy stated that they are intended to be real plants. Ms. Sender stated that Wexford Developments was recently approved for a project on 1<sup>st</sup> Street and Farmer. They went through a study with landscape architects and the building is fully biodiverse, self-screening, self-shading, and includes plants on all four sides of the building. They are incorporating the same green techniques into this project as well. Vice Chair Fackler stated that he is not seeing a lot of trees on the amenity deck. Is everything low-level landscape, he asked? Mr. Duffy stated that putting trees on an amenity deck presents some engineering challenges but is not impossible. The application package does not include a view from above. There would be a landscape buffer around the perimeter of the amenity deck. Mr. Duffy said they are trying to keep activity away from the perimeter of the deck due to safety concerns. Vice Chair Fackler stated that his major concern is the Walker House, and he is not thrilled about the idea of someone's neighborhood park being invaded by the building, which has no reason for being there other than it was convenient. Vice Chair Fackler said he would urge the City as well as the developer to look for a more appropriate alternate site, possibly the city's west side neighborhoods, where the aging character of the house would fit in better. Vice Chair Fackler asked if the developer is providing any additional parking for the reuse of the sanctuary. Ms. Sender stated that under the CC parking requirements, a building utilized as a restaurant has zero parking requirements. There is significant parking surrounding the building. Ms. Sender stated that the project is significantly close to the light rail and streetcar. Ms. Sender stated that they have confirmed there are no utilities in the alley, so there will not be a requirement to dig up the alley in the future. The alley will be lit and designed. Vice Chair Fackler asked about the likelihood of multiple 3- and 4-bedroom units being controlled by one person or entity. Ms. Sender stated that is not the intent of this developer or project. This project is not renting by the bed and is not focused on student housing. The intent is to bring families into downtown. Vice Chair Fackler asked if he were to walk into the leasing office and ask to rent all of the units on the south side, would that be possible? Mr. Charles Goode from Wexford Developments stated that there will be measures in place that would prevent someone from doing that. This is going to be young professional housing, he said. The units will be for rent, not for sale. Vice Chair Fackler asked if there was a possibility of subleasing. Mr. Goode stated that a sublease would be possible, but regarding an individual leasing a mass number of units within the project, that would not be possible. Vice Chair Fackler asked if there is a conversion possibility on the units at some point in the future. Mr. Goode stated that they have not gotten to that point yet. But that is not their intent. Vice Chair Fackler asked if parking was first come, first serve or if there will be designated parking leased by the individual units. Mr. Goode stated that parking will be available to the residents. Currently, their plan provides for 675 parking spaces. That is right in line with other projects in the area.

Commissioner Robinson stated that relocating the house seems to be a sore topic because it would alter the historic integrity of the structure. Walking around downtown recently, she said, the character has changed considerably, and historic houses are almost impossible to find. We should think about how to retain houses we want to keep historically, but maybe the downtown core is not the place for them. Retaining the sanctuary seems inappropriate. If it does not look like a church and would not maintain its historic characteristics, why are we keeping the building? Dr. Lechner stated that under this proposal, if the sanctuary were to remain in place with a historic overlay over it, it would remain in the Tempe Historic Property Register. Any changes to the façade to the building would require going through the Historic Preservation Office or HPC. The sanctuary would still have the protection of designation. The owner or tenant could not make any changes they wanted without first gaining approval.

Chair Woodson asked if the Walker House relocation has been discussed with the State Historic Preservation Office (SHPO) yet. Dr. Lechner stated that he has not spoken with SHPO yet due to receiving the plans recently, but he will be in contact with SHPO. Chair Woodson asked that Dr. Lechner make it a priority as SHPO may have some insights on what approach could be taken. Chair Woodson asked if the HPC will have a role in the decision-making on the Walker House. Dr. Lechner stated that HPC would not have as much of a role as it will with the 1<sup>st</sup> Congregational Church, possibly more of an advisory role. Dr. Lechner stated he will reach out to SHPO for thoughts on relocation. Chair Woodson requested that the matter come back to the HPC after a decision is made. This house is of great interest to the Commission, he said.

Commissioner Kurooka said that the report states that the Walker House can be relocated if it is feasible to move. That seems to be open to interpretation. Commissioner Kurooka asked to see more commitment than that. What will make it feasible to move? Someone may say it is not possible to save. It seems like the developer is presently open to relocating the house, but that's not confirmed in the report. Commissioner Kurooka stated she also agrees with the problem of relocating the Walker House to a park, as the City already has limited resources. Relocating a house to a park means it will need maintenance and funding.

- 5) Request for Certificate of Appropriateness to install arm rests in the **OLD MILL AVENUE BRIDGE** alcoves. The applicant is the Tempe Homeless Solutions Task Force. The presenter is Paul Bentley, City of Tempe Deputy Human Services Director. **(PL230190/HPO230003)**

Dr. Paul Bentley, Deputy Human Services Director gave a presentation on a proposal to install new arm rests in the Old Mill Avenue Bridge alcoves. The Tempe Homeless Solutions Task Force meets on a weekly basis. The team includes representatives from the City Manager's Office, Police Department, Community Health and Human Services Department, Tempe Fire and Medical Rescue, City Attorney's Office, Communications and Marketing, and many other personnel within the City. One year ago, the team brought forward a specific health and safety concern related to individuals utilizing the alcoves on the Old Mill Avenue Bridge as shelter space. The HPC provided specific feedback and a request to provide better solutions that would not diminish the alcoves' historical integrity. The Homeless Outreach Team now completes daily walks in the downtown and on the Old Mill Avenue Bridge. The Police Department has also expanded its services to provide greater assistance in the downtown area. The Traffic Engineering group consistently addresses debris and trash in downtown and on the bridge. Even with the current strategies in place, the alcoves continue to be a place where trash and debris must be addressed on a continual basis. Every engagement by the Homeless Outreach Team is documented. Since June 1, the team has made 34 engagements through the walking program. Of those engagements, 17 contacts were made on the Old Mill Avenue Bridge; there has been one individual identified as using the alcoves as a shelter space. With the engagements, the team is providing outreach, resources, shelter options, and a space for individuals to connect to housing solutions. Through those engagements, three of the individuals took the team up on their offers. A year ago, the team's proposal was to install a of gate structure on the alcoves. The HPC asked the team to find instead a solution with little or no impact to the bridge, whether it is music, lighting, or more personnel to monitor activity. The current request is not to place armrests in all 8 alcoves, but to place sample armrests in 4 of the 8 alcoves for a test. The City will continue to gather data and, after 90 days, determine if there is any significant change in the data (in regard to inappropriate use) with the alcoves that have armrests versus the ones that do not.

Mr. Isaac Chavira, Interim Deputy Direction of Transportation, gave a presentation on the new armrest installation. The new armrests can be installed and clamped on the existing base of the alcove benches. This uses a  $\frac{3}{4}$ " bolt. At this time, the bolt is not theft resistant unless it is tap welded or fitted with a tamper-proof bolt.

Chair Woodson asked the Commission if there were any questions for the presenters.

Vice Chair Fackler congratulated Dr. Bentley and Mr. Chavira for finding a solution that did not directly impact the alcoves. This gives someone out for a walk a place to rest without having to worry if the gates were opened after having been closed the night before. Vice Chair Fackler asked if it is powder coating or paint on the armrests. Mr. Chavira stated that it is powder coating. Vice Chair Fackler stated that his only concern with the design is the sharp corners on the handles. Those would need be rounded. The drawing shows them as

rounded. If the ones that are currently in place are not rounded, Vice Chair Fackler recommends they be changed as part of the proposed three-month study program. Vice Chair Fackler asked if the 14 other contacts that were made on the bridge were separate individuals or if some were the same person. Dr. Bentley stated that 5 of the contacts were repeat. Vice Chair Fackler stated that this is something he can get behind and approve because it is not directly impacting the structure itself.

Commissioner Robinson stated that she has some concerns with the solution, one being that the edges are squared off and could be dangerous. Second is her concern that it engages the floor/base. The City's cleaning of the alcoves will become more complicated because debris will become lodged against the base. There is no open floor anymore. A solution could be something that wraps around and attaches to the base of the seat, something sleeker and more like a grab bar. Commissioner Robinson stated that a gate could be a better solution. [HPO note: Commissioner Robinson was not an HPC member a year ago when the gate solution was presented to the Commission.] Mr. Chavira explained that last year they did come to the Commission with a proposal to enclose the alcoves with gates, which would be kept open during certain hours. The HPC expressed concern with the intrusiveness and weight of the gate. That earlier plan also would have required drilling into the existing concrete with 3-inch or 4-inch anchors. Mr. Chavira stated that they took a second look at how they could prevent individuals from sleeping on the benches and still allow the alcoves to be utilized as sitting areas. The armrests would be engaged with the base of the seat. From a cleaning perspective, it has not been intrusive. In a response to another comment by Mr. Chavira, Commissioner Robinson asked, if the armrests can be removed in an instant, why couldn't the unsheltered person easily remove them so they could sleep on the bench? Mr. Chavira stated that non-City staff would not be able to remove them in an instant. Commissioner Robinson said she does not believe this will deter any unsheltered person from sleeping on the bench. Commissioner Robinson said she believes that from a design perspective a better deterrent could be designed. A nice, appropriately designed gate, with limited hours of operation, would be a better solution.

Vice Chair Fackler described the gate design that was presented to the Commission last year. The alcoves, according to staff, are about 8 feet across and 12-13 feet high. The proposal was to put bars across the alcove with a gate. Commissioner Fackler said the bars must go high enough so someone does not climb over them. Someone who wants to get in the alcove could damage the gate by shaking it until it gave way. That would also damage the bridge. Vice Chair Fackler stated that he likes this solution because it does not harm the historic structure.

Commissioner Davis stated that it was said that the armrest placement is ADA compliant, but she is not seeing any measurements stated in the reports. What is the width of the middle seat? Mr. Chavira stated that he did not measure the width, but he made sure the design concept and pictures were sent to Ms. Nanette Odell, COT ADA Compliance Specialist, who approved it. Commissioner Davis asked how long the armrests have already been installed for and what kind of data has been received so far. Are people sleeping sitting up now? Dr. Bentley stated that the pilot has been in place about one month in one alcove. While his team receives GPS data, it is not precise enough to allow them to see if the activity is on the east side or the west side of the bridge. They know there is activity occurring on the south end of the bridge, but they cannot confirm in which alcove. The intention of the pilot project is to put the armrests in the alcove directly across from the one that already has an armrest in it, as well as in two alcoves on the north end to collect data.

Chair Woodson stated that the reports show the team has funding to purchase all of the armrests and asked, is that for eight alcoves? Mr. Chavira stated that they do have funding for all eight alcoves, and the cost listed in the staff memo is a little higher because it includes design costs. The City would have to pay a little more for a design to round off the edges. Chair Woodson asked, why not just install the arm rests in all eight alcoves rather than do a test run on only four of them? Mr. Chavira stated that one of the discussions they had is that they are a data-driven city. Yes, they have the funding available for all eight, but if the data shows they do not need to address the issue in all eight alcoves, they would rather install them only where they're needed.

Commissioner Robinson asked, regarding data collection, do all of the alcoves get filled every night? If not, what prevents someone from going to one without arm rests? How will you know if you are solving the problem? Mr. Bentley stated that his team wishes to be purposeful in doing what they think is appropriate.

The data collection will inform the Task Force, so if the activity continues on the north and south sides, then it will be clear that the armrests are not working. Commissioner Robinson asked if the armrests for all eight alcoves have already been produced. Mr. Chavira stated no; the only armrests that have been produced are the one the Commission was shown and the two in the field. Commissioner Robinson stated that the data tests should be run during the winter because there are more unsheltered persons who might migrate to this part of the country at that time due to weather.

Chair Woodson asked how City staff came up with this idea. He asked, is there another city that you've seen this used in? Is it effective? Mr. Chavira stated that the idea was not farfetched. His team got the idea from the city's existing bus shelters. Chair Woodson stated that at the beginning of his presentation, Dr. Bentley said he was not going to go back and discuss the data from last year, but could he? Is the data from last year unchanged, specifically relating to the bridge? Dr. Bentley said he does not have that information in front of him. If the data is available, he will get the information to the Commission.

Commissioner Kurooka stated that her issue with the gates was that, visually, they were very rejective. It does not feel like a big rejection, though, with arm rests being placed on the alcoves. The curved edges may also keep people from writing on the armrests.

Mr. Bentley thanked the Commission for the feedback and the opportunity to present.

Chair Woodson echoed Vice Chair Fackler's earlier comments about the effectiveness of the solution.

Dr. Lechner stated that his original understanding was that the applicant was going to install the armrests on all eight alcoves. The Commission might consider deferring the Certificate of Appropriateness decision to a later date once the trial has been completed and the applicant has a chance to come back and update the Commission. Dr. Lechner stated that he would propose a simple resolution if the Commission were interested in approving the armrests for the four alcoves for the purpose of the trial.

**Motion** by Vice Chair Fackler for a resolution to allow preliminary testing of the arm rest product for a period of up to 6 months, with design changes: second by Commissioner Davis. Motion passed on **7-0** vote.

**Ayes:** Chair Woodson, Vice Chair Fackler, Commissioners Davis, Robinson, Williams, Larson, and Kurooka

**Nays:** None

**Abstain:** None

**Absent:** Commissioners Engnell and Montero

- 6) Request for approval of HPC Chair Kyle Woodson and Vice Chair Dave Fackler's letter to Mayor Corey Woods regarding preservation of the **WATSON'S FLOWERS BUILDING**.

Chair Woodson stated that he has conversed with Dr. Lechner about this topic. Chair Woodson felt that the Commission needed to weigh in more heavily on this issue. The motivation in writing the letter was to open a discussion with the Council.

Commissioner Kurooka stated that she thinks the letter is great and thanked Chair Woodson for writing it. Commissioner Kurooka stated that what bothers her most is that the pending Watson's Flowers property redevelopment will partially rely on City funding. The Tempe Community Action Agency (TCAA) and City should be trying to maintain the historic building. Dr. Lechner stated that there has been no City funding used for the purchase of this property. The "Affiliate" (Tempe Coalition for Affordable Housing) bought the property without City funding. TCAA may end up purchasing the property from the Affiliate. TCAA also does not receive City funding. Chair Woodson stated that while the parcel is not City owned, it is still part of the overall affordable housing project, which is a City initiative. Chair Woodson stated that the perception from the Commission and the public in general is that this is a City project. Dr. Lechner confirmed that the Watson's property has been incorporated into the larger Apache HUD Affordable Housing project, a City of Tempe initiative.

Commissioner Robinson thanked Chair Woodson and Vice Chair Fackler for writing the letter. She asked: What is the process for demolishing a building that is eligible for the Tempe Register? Should that have to come to Commission? Dr. Lechner stated that officially it has not been determined that the building will be demolished. That is the impression he has received from the developer, though. For a Historic Eligible property, the City Code specifies that for any plan to demolish or change a building, a request for a demolition permit must be routed to the HPO for review. The HPO would then have the option of imposing up to a 30-day stay on issuance of the demo permit. There is no requirement to involve the HPC, since the HPC is not authorized to make any decisions if a property is Historic Eligible. Commissioner Robinson stated that in the letter, both authors included multiple citations where it was encouraged that various parties be consulted. Commissioner Robinson stated that she supports the letter. She asked: Is the letter stating that this process should have been brought before the HPC for review? Chair Woodson stated that the goal of the letter was to reinforce the HPC's previously stated position on the building's future. There is no formal hook that anyone in the City must get HPC approval.

Vice Chair Fackler stated that letter is designed to be a red flag. Everything we have seen in the two studies on the Watson's Flowers property ask if there is anything worth preserving there. The first one came back yes, and the second one came back maybe. Both studies looked at how the building could be demolished, not how it could be reused. The historic building comprises less than 10% of the entire site. Vice Chair Fackler said that you see many projects nationwide where a historic building is used as a focal point for a project. There is potential for this building to be utilized. We have not seen any attempt to try and reuse this facility. The approach seems to be all wrong. Was any thought given to designing the pending housing project around this historic structure? This is one building along Apache that could be saved.

Commissioner Larson stated that he likes the letter and its substance. He asked: How are you going to deliver this to the Mayor and City Council? Are you going to print a hard copy and mail it or email it? Chair Woodson said he is unsure. Chair Woodson stated that he has seen previous letters printed on City letterhead. If there is no letterhead, he said, we can print it and sign it. Dr. Lechner stated that there is no City-approved HPC letterhead. Commissioner Larson stated that from a presentation standpoint, on the first page, the letter should indicate it is from the Commission and regarding potential preservation of the Watson's Flowers building. From a formatting standpoint, there is room for improvement, though the content of the letter is robust. Some of the paragraphs are intimidating because they are large. Commissioner Larson posed a couple of questions to Chair Woodson: Could we improve how this is presented and polish the formatting? Are you and Vice Chair Fackler open to some suggestions on presentation? Chair Woodson stated, yes, that is the purpose of bringing this to the Commission tonight. Dr. Lechner stated that all communication must be one to one in email between the Commission, and not to the entire Commission. Commissioner Larson stated that he will reach out to Chair Woodson one on one so that he can receive a Word copy of the document for the purpose of making some improvements that he will send back to Chair Woodson.

Staff Mr. Ambika Adhikari stated that HPC can send the letter through the HPO or via the Council Communicator email address, which goes to the Council Members and the Mayor.

Commissioner Robinson asked if the letter is focusing on the fact that the proposition of retaining the building was not brought to the Commission or if the emphasis is on saving of the building. She said it appears that we are focusing on saving the building, but from a broader perspective, you may want to say this is just one example of why the HPC should be engaged earlier on in the process for HP-related issues. Chair Woodson agreed and asked Commissioner Robinson to send some suggested text via email.

Chair Woodson stated that the main idea with the letter is to present information from approved City documents to inform a decision about whether to preserve the Watson's Flowers building. This is not a brand-new idea. The City has already approved these documents, which support this very idea.

**Motion** by Vice Chair Fackler to approve pending any revisions to the letter: second by Commissioner Robinson. Motion passed on **7-0** vote.

**Ayes:** Chair Woodson, Vice Chair Fackler, Commissioners Davis, Robinson, Williams, Larson, and Kurooka

**Nays:** None

**Abstain:** None

**Absent:** Commissioners Engnell and Montero

## 7) Chair / Staff Updates

Chair Woodson had no updates.

Mr. Adhikari updated the Commission on General Plan 2050. The draft now includes a discussion of the proposed Downtown Historic Core. The next draft will be released Friday, July 14. General Plan 2050 will go to City Council for hearings on August 10 and August 24. Comments can be made at [Tempe.gov/2050.com](https://tempe.gov/2050.com) until the adoption date.

Vice Chair Fackler stated that the Downtown Historic Core concept is supported by the Mayor. This is a good step forward.

Dr. Lechner updated the Commission on the McKemy-Riggs Zoning Map Amendment request. At the April 2023 HPC meeting, the Commission recommended approval of the request. At the May 9<sup>th</sup> Development Review Commission (DRC) meeting, the DRC also recommended approval. On June 15, City Council approved the request, resulting in the addition of the McKemy-Riggs House property to the Tempe Historic Property Register.

Dr. Lechner updated the Commission on the Historic Preservation Plan implementation process. HPC recommended approval of the plan in May 2022. Council adopted the plan in June 2022. Some of the few remaining priorities to be implemented deal with City Code text amendments that the HPO and the Planning Division are planning to make to the Historic Preservation Ordinance, as well as the creation of a City of Tempe-Tribal government memorandum of understanding or consultation policy.

Dr. Lechner updated the Commission on the City of Tempe Cultural Resources Inventory and Historic Properties Treatment Plan. The tentative plan is to agendize a request for approval of the finalized draft as early as next month. Assuming approval by HPC, a request for official adoption by City Council would be the next and final step.

Dr. Lechner updated the Commission on the City's Moeur Park rehabilitation project, which has been completed.

Dr. Lechner updated the Commission on the Bauer House, 599 West 5<sup>th</sup> Street. The Community Development Department received a completed demolition permit request for the property on July 6. The property is classified as Historic Eligible for the Tempe Historic Property Register. Dr. Lechner initiated a 30-day stay of demolition, until August 4. Dr. Lechner made the case for preservation to the applicant. According to the applicant, the developer feels that preservation is not an option. Per the HPO's request, the applicant is reaching out to the developer to determine if they can complete as-built drawings of the house and allow Dr. Lechner to photograph the property.

Commissioner Robinson asked if the Citywide HPTP is available to review online. Dr. Lechner stated that he will resend the updated document to the Commission when it is available.

Chair Woodson asked if the Commission could play any more of a role in the demolition decision with the Bauer House. Dr. Lechner stated that since it involves private property and a private developer, there is not much more the HPC can do. Dr. Lechner stated that one of the possible code text amendments he referenced earlier is to increase the stay period on a demolition permit request for a Historic Eligible

property from 30 to 60 days.

Commission Kurooka asked if there is a way to fund the City purchase of the property. Dr. Lechner stated that is a valuable suggestion. There is always a challenge of locating funding. In the last funding request cycle for the City, the HPO was able to put in a request for 2025 or 2026 to fund a program that would allow individuals who have designated properties to apply for matching funds from the City for use in rehabilitating those properties. That is one way to help encourage the future preservation of historic properties.

Vice Chair Fackler stated that he attended a recent event with the Mayor and others that are involved with historic preservation. He asked: Is there a way for the City to put a historic overlay on the Cultural Resource Areas listed in the General Plan? If something like this was approved, the City could move forward with putting these properties under more protection. Vice Chair Fackler said the Mayor is supportive of a historic preservation initiative as part of the next bond election.

**8) Current Events / Announcements / Future Agenda Items**

**Member Announcements**

**Staff Announcements**

Dr. Lechner stated there will likely be an August HPC Meeting. Chair Woodson asked to receive an update from City staff on the Tempe's Refresh project at the next meeting.

Meeting adjourned by Chair Woodson.

Hearing adjourned at 8:43PM

Prepared by: Jennifer Daniels, Administrative Assistant

Reviewed by: Zachary Lechner, Historic Preservation Officer

jd:zl







Powder coating option available: Need to specify Color Choice

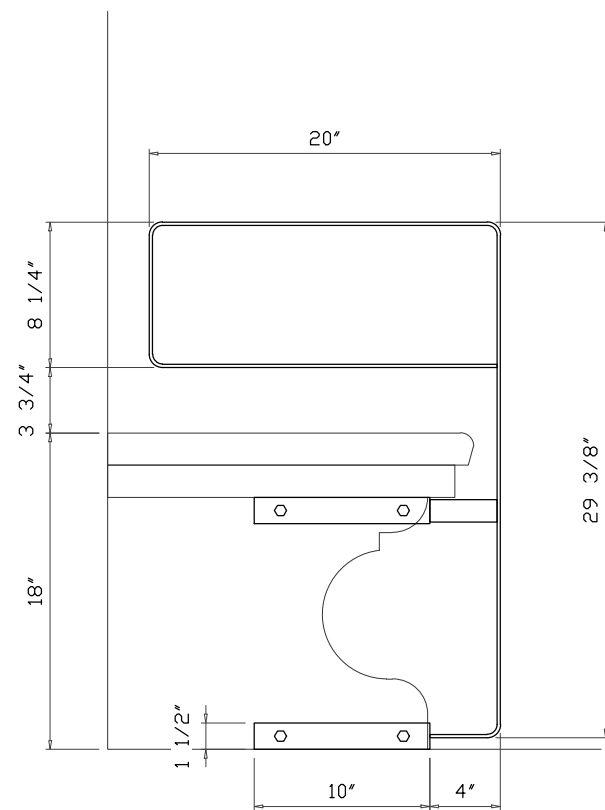

1 1/2" x 3/16" S/S FLAT BAR

FIG. A

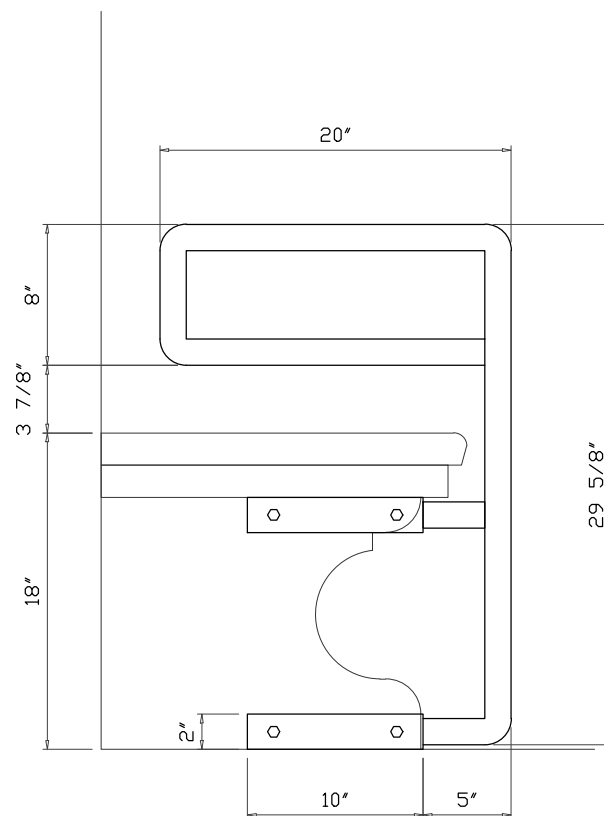

1 1/2" SQ. S/S TUBING

FIG. B

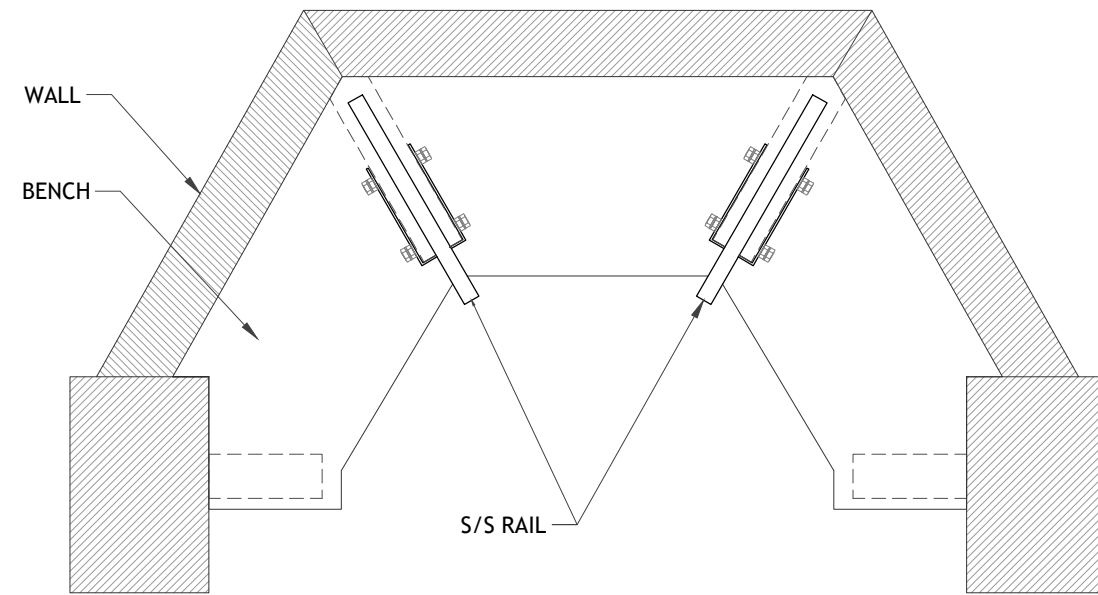

PLAN VIEW, TYP. (1) LOCATIONS

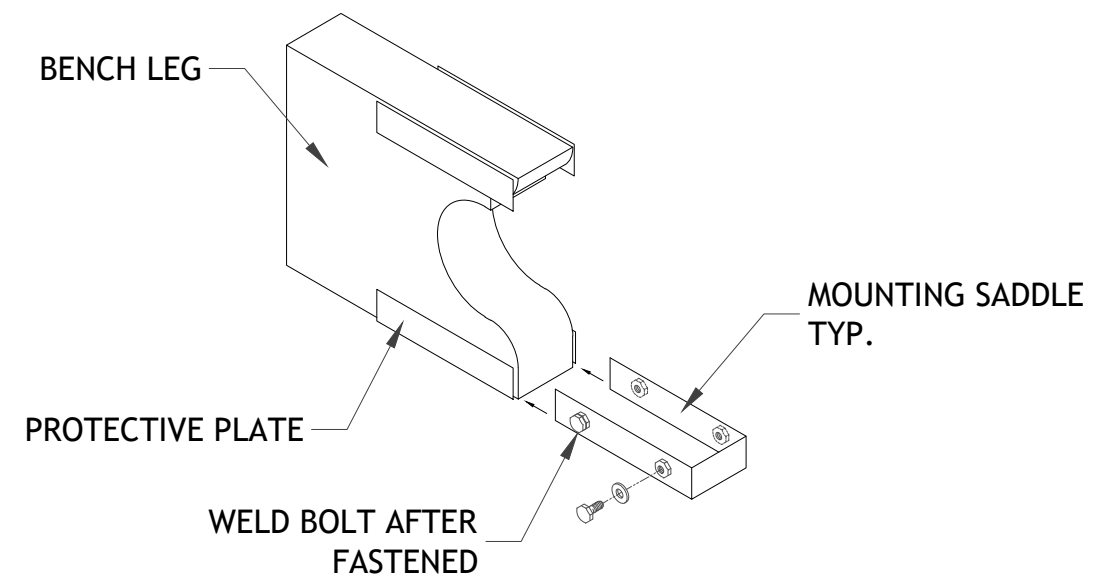

BENCH DIVIDER RAILS (QTY.2)



**GENERAL NOTE**  
 PLANS ARE APPROVED AS DRAWN (WITH CORRECTIONS AS NOTED). ITEMS WILL BE FABRICATED PER THESE PLANS. JAYCO ASSUMES NO RESPONSIBILITY IF THE PLANS DO NOT FOLLOW SPECIFICATIONS.

REVISIONS:

- 1
- 2
- 3

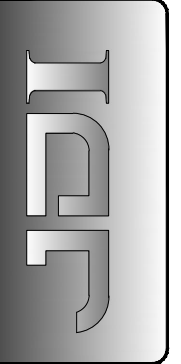

JAYCO DESIGN AND INSTALLATIONS  
 2560 N33rd Avenue  
 Phoenix, AZ 85009  
 jaycoinstallations.com

TEMPE LAKE BRIDGE  
 TEMPE, AZ

SHEET NAME:  
 CUSTOM STAINLESS

DATE: 02-15-2023

SCALE: AS NOTED

DRAWN BY: JJM

PROJECT NO. 00-0000-0

SHEET NO.

SS1